

# QorIQ P2041 Reference Design Board



Part No. P2041RDB-PC



QorIQ Multicore Processor Development

## P2041 Reference Design Board

Also supporting P2040



### Overview

The P2041RDB is a compact (micro-ATX), highly integrated reference design board featuring the quad-core P2041 device. With its 1.5 GHz P2041 and rich input/output (I/O) mix, the board is designed for evaluating the P2041 and P2040 in networking and Ethernet-centric applications, such as control plane and mixed control plane/data plane in switches and routers, unified threat management, base station network interface and baseband cards, aerospace and defense, multifunction printers and factory automation.

The P2041RDB can help shorten your time to market. The board, which exercises most capabilities of the device, can serve as a reference for the customer's hardware development. It can also be used as a debug

tool to check behaviors on the board compared to behaviors seen on customer boards. It can be used for software development and performance evaluation prior to the customer's own board being ready. While the P2041RDB uses the superset P2041 device, it can also be configured to look like the more cost-effective subset device, the P2040.

The P2041 processor is based upon the e500mc core, built on Power Architecture® technology, offering speeds of 1200–1500 MHz. It has a three-level cache hierarchy with 32 KB of instruction and data cache per core, 128 KB of unified backside L2 cache per core, and 1 MB of shared frontside CoreNet platform cache fronting the memory controller. I/Os include 10 SerDes lanes running at up to 5 GHz, multiplexed across three PCI Express® Gen2 controllers, one 10 gigabit Ethernet (GE) XAUI interface, five 1 GE SGMII interfaces, four 2.5 Gb/s SGMII interfaces, two Serial RapidIO (version 1.3 with features of version 2.1) interfaces, two SATA 2.0 interfaces and the high-speed Aurora debug interface. It has a 64-bit DDR3 and DDR3L (low power) DRAM interface with 8-bit ECC support running at up to 1333 MHz data rate. It includes two USB 2.0 interfaces (including PHY), two dual universal asynchronous receiver/transmitters (DUARTs), an SD/MMC interface, a 16-bit

local bus, four I<sup>2</sup>C and SPI. It also includes the accelerator blocks collectively known as the Data Path Acceleration Architecture (DPAA) that offload various tasks from the core, including routine packet handling, security algorithm calculation and pattern matching.

The P2041RDB offers significant flexibility in allocating its 10 SerDes lanes to various functions. Its base configuration supports three SGMII ports and two RGMII ports, a 2-lane PCI Express slot, and two SATA ports (one populated with a 320 GB hard drive). In other configurations, it can have two 4-lane PCI Express slots, which can be populated with off-the-shelf PCI Express cards or Freescale's XAUI-RISER card.

The P2041RDB memory system supports 4 GB of DDR3 at 1333 MHz. It has 128 MB of NOR flash, a 256 KB I<sup>2</sup>C EEPROM and 16 MB of SPI memory. It also includes two USB 2.0 receptacles and an SD card slot.

The P2041RDB is pre-loaded with an Embedded Linux Essentials for QorIQ Processors with Data Path Acceleration development kit. This kit includes a 2.6.x.x SMP Linux kernel, hugetlbfs for applications with a large memory footprint, user space DPAA for high-performance packet handling, u-boot, the GCC tool chain and Mentor System Builder, among many other features.



## P2041RDB

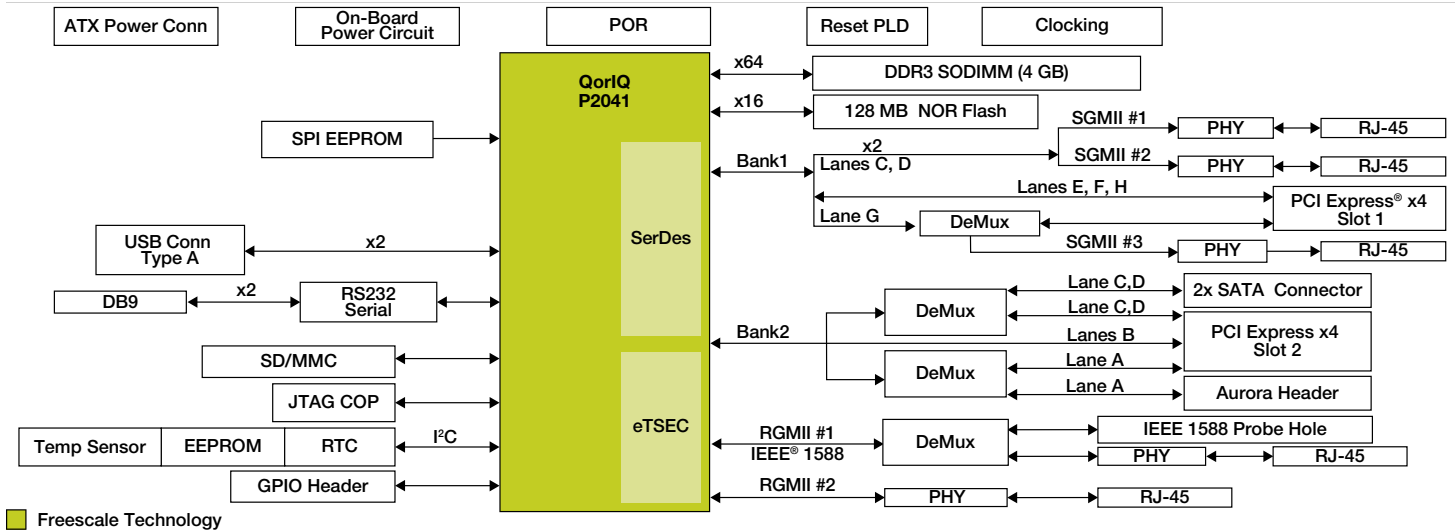

## P2041RDB Board Features

### Processor

- P2041, 1.5 GHz core with 1333 MHz DDR3 data rate
- Multiple SysClk inputs for generating various device frequencies
- Switch to change system version register from P2041 to P2040 personality

### Memory

- 4 GB unbuffered DDR3 SDRAM SO-DIMM (64-bit bus), 1333 MHz data rate
- 128 MB NOR flash single-chip memory
- 256 KB M24256 I<sup>2</sup>C EEPROM
- 16 MB SPI memory
- SD connector to interface with an SD memory card

### PCI Express

- Two x4 PCI Express slots

### SATA

- One internal 2.5" SATA 2.0 drive, 320 GB
- One extra SATA connector

### USB 2.0

- Two High-Speed USB controllers
- Two USB 2.0 Type A receptacles

### Ethernet

- Supports five 10/100/1000 ports with no add-in cards
- dTSEC1—dTSEC3 as SGMII to PHY: Vitesse VSC8221
- dTSEC4—dTSEC5 as RGMII to PHY: Vitesse VSC8641
- 10 GE can be supported with Freescale's optional XAUI-RISER card

### DUART

- Two DUART DB9 ports
- Each DB9 supports two UARTs, each up to 115200 bps

### Debug

- JTAG/COP
- Aurora high-speed connector

### Other

- IEEE<sup>®</sup> 1588 connector for Symmetricom option card
- Real-time clock on I<sup>2</sup>C
- Temperature sensor on I<sup>2</sup>C
- Eight general purpose I/Os

For more information, visit [freescale.com/QorIQ](http://freescale.com/QorIQ)



Freescale, the Freescale logo and QorIQ are trademarks of Freescale Semiconductor, Inc., Reg. U.S. Pat. & Trm. Off. The Power Architecture and Power.org word marks and the Power and Power.org logos and related marks are trademarks and service marks licensed by Power.org. All other product or service names are the property of their respective owners. © 2011 Freescale Semiconductor, Inc.

Document Number: P2041RDBFS / REV 1