

Type CDHC Snap-In Hybrid Carboncap Power Ultracapacitors

Large Cylindrical Type



The snap mount hybrid ultracapacitors are designed for board mountable power backup applications. The best applications for these type of ultracapacitors have low power, low energy, and low charge/discharge cycle rates. The main feature of these ultracapacitors is the ability to be rapidly charged preferably followed by a slow discharge. Applications include solar lighting, LED lighting, and portable devices.

Highlights

- Rapid charge
- Circuit board mountable
- Standard snap-In design

Specifications

Operating Temperature Range	-40 °C to +60 °C
Storage Temperature Range	-40 °C to +65 °C
Rated Voltage Range	2.3 Vdc, 2.50 Vdc rated surge (do not discharge below 1 Vdc)
Capacitance Range	220 F to 1000 F
Capacitance Tolerance	-5% / +10%
Life at Room Temperature	10 years at rated voltage and 25 °C Capacitance change ≤20% ESR change ≤100%
Life Test	1000 h @ rated voltage and +50 °C Capacitance change ≤30% decrease ESR change ≤100% increase
Cycle Test	>10,000 cycles (rated to half rated voltage at +25 °C) Capacitance change ≤20% decrease ESR change ≤100% increase
Shelf Life	1000 h without voltage at +60 °C Capacitance change ≤20% decrease ESR change ≤100% increase
RoHS Compliant	

Ratings

Part Number	CDHC221K2R3SR	CDHC301K2R3SR	CDHC821K2R3SR	CDHC102K2R3SR
Terminal Configuration	Snap In	Snap In	Snap In	Snap In
Capacitance (F) (Discharge w constant current at 25°C)	220	300	820	1000
ESR, DC (mΩ), Max	40	25	12	14
ESR, AC @ 1kHz (mΩ), Max	25	15	6	7
Current - Max Peak (A) (1 s discharge rate to 50% of rated Voltage)	26	41	87	77
Leakage current (mA), Max after 72 h at +25 °C	0.20	0.55	0.50	0.70
Usable Power Density, Pd (kW/kg) (Per IEC 62391-2)	0.63	0.94	0.76	0.50
Impedance match power, (kW/kg)	2.1	3.3	3.1	2.1
Gravimetric energy density, Emax (Wh/kg)	5.2	6.6	7	5.2
Energy available (Wh) (At rated voltage)	0.13	0.18	0.49	0.60
Weight (kg)	0.025	0.027	0.07	0.115
Maximum Continuous Current (Arms) (ΔT=20°C)	5	5.5	7.5	8
Short circuit current (A)	92	153	383	329

Type CDHC Snap-In Hybrid Carboncap Power Ultracapacitors

Large Cylindrical Type

Part Numbering System

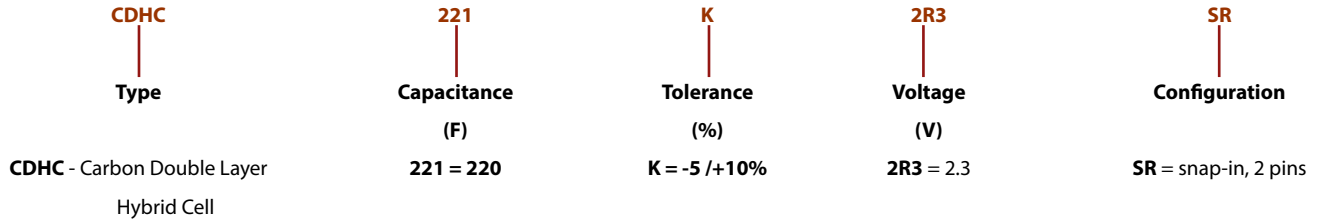

Outline Drawing and Dimensions

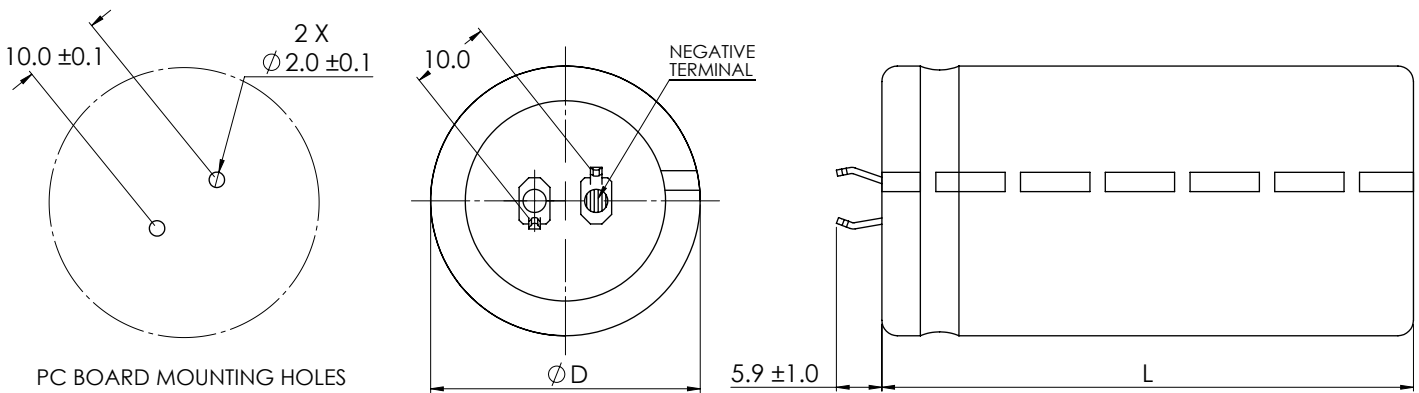

Snap Mount Hybrid Type Part Number	Dimensions (mm)	
	D (+1/-0mm)	L (± 2 mm)
CDHC221K2R3SR	22	45
CDHC301K2R3SR	22	45
CDHC821K2R3SR	27	80
CDHC102K2R3SR	35	88

Do not reverse polarity.

Notice and Disclaimer: All product drawings, descriptions, specifications, statements, information and data (collectively, the "Information") in this datasheet or other publication are subject to change. The customer is responsible for checking, confirming and verifying the extent to which the Information contained in this datasheet or other publication is applicable to an order at the time the order is placed. All Information given herein is believed to be accurate and reliable, but it is presented without any guarantee, warranty, representation or responsibility of any kind, expressed or implied. Statements of suitability for certain applications are based on the knowledge that the Cornell Dubilier company providing such statements ("Cornell Dubilier") has of operating conditions that such Cornell Dubilier company regards as typical for such applications, but are not intended to constitute any guarantee, warranty or representation regarding any such matter – and Cornell Dubilier specifically and expressly disclaims any guarantee, warranty or representation concerning the suitability for a specific customer application, use, storage, transportation, or operating environment. The Information is intended for use only by customers who have the requisite experience and capability to determine the correct products for their application. Any technical advice inferred from this Information or otherwise provided by Cornell Dubilier with reference to the use of any Cornell Dubilier products is given gratis (unless otherwise specified by Cornell Dubilier), and Cornell Dubilier assumes no obligation or liability for the advice given or results obtained. Although Cornell Dubilier strives to apply the most stringent quality and safety standards regarding the design and manufacturing of its products, in light of the current state of the art, isolated component failures may still occur. Accordingly, customer applications which require a high degree of reliability or safety should employ suitable designs or other safeguards (such as installation of protective circuitry or redundancies or other appropriate protective measures) in order to ensure that the failure of an electrical component does not result in a risk of personal injury or property damage. Although all product-related warnings, cautions and notes must be observed, the customer should not assume that all safety measures are indicated in such warnings, cautions and notes, or that other safety measures may not be required.