

RM 6 Core and Accessories

Individual parts	Part no.	Page
Adjusting screwdriver (for assembly only)	B63399	220
Matching handle	B63399	220
Adjusting screw	B65659	220
Core	B65807	212
Clamps	B65808	217
Insulating washer 1	B65808	217
Coil former	B65808	214
Core	B65807	212
Threaded sleeve (glued-in)		
Insulating washer 2	B65808	217

FRM0048-K

Example of an assembly set

Also available:

Coil former for SMPS transf.	B65808	215
Coil former for power applications	B65808	216
SMD coil former	B65821	218, 219
RM 6 low profile:		
Core	B65807-P	225
SMD coil former	B65821	226
Clamp	B65808	226

- In accordance with IEC 60431
- Core without center hole for transformer applications
- RM cores are supplied in sets

Magnetic characteristics (per set)

	with center hole	without center hole	
$\Sigma l/A$	0,86	0,78	mm ⁻¹
l_e	26,9	28,6	mm
A_e	31,3	36,6	mm ²
A_{min}	—	31	mm ²
V_e	840	1050	mm ³

Approx. weight (per set)

m	4,9	5,3	g

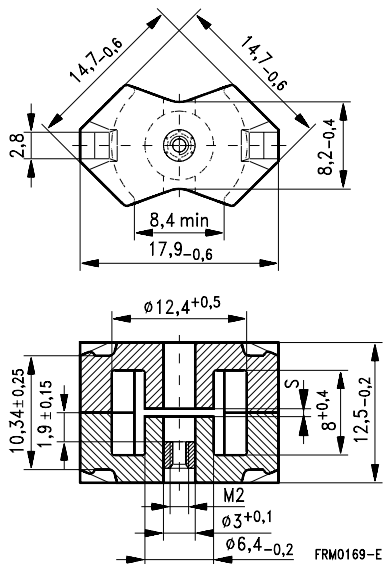

Gapped

Material	A_L value nH	s approx. mm	μ_e	Ordering code ¹⁾ -J without center hole -N with threaded sleeve -C with center hole
K1	40 ± 3 %	0,80	27,4	B65807-+40-A1
M33	63 ± 3 %	0,60	43,2	B65807-+63-A33
	100 ± 3 %	0,38	68,5	B65807-+100-A33
N48	160 ± 2 %	0,22	110	B65807-+160-G48
	250 ± 3 %	0,12	171	B65807-+250-A48
	315 ± 3 %	0,08	216	B65807-+315-A48
	400 ± 3 %	0,05	274	B65807-+400-A48
N41	250 ± 3 %	0,17	155	B65807-J250-A41
N26	1000 ± 10 %	0,03	685	B65807-+1000-K26

1) Replace the + by the code letter "C" or "N" for the required version. Standard version is "C".

Ungapped

Material	A_L value nH	μ_e	A_{L1min} nH	P_V W/set	Ordering code -C with center hole -J w/o center hole
N26	2200 + 30/- 20 %	1500			B65807-C-R26
N30	4300 + 30/- 20 %	2670			B65807-J-R30
T35	6200 + 30/- 20 %	3850			B65807-J-R35
T38	8600 + 40/- 30 %	5340			B65807-J-Y38
T42	12300 + 40/- 30 %	7630			B65807-J-Y42
N49	1700 + 30/- 20 %	1060	960	0,15 (50 mT, 500 kHz, 100 °C)	B65807-J-R49
N67	2200 + 30/- 20 %	1490	1450	0,64 (200 mT, 100 kHz, 100 °C)	B65807-J-R67
N87	2400 + 30/- 20 %	1490	1450	0,51 (200 mT, 100 kHz, 100 °C)	B65807-J-R87
N41	3100 + 30/- 20 %	1920	1450	0,16 (200 mT, 25 kHz, 100 °C)	B65807-J-R41

Coil former

Material: GFR thermosetting plastic (UL 94 V-0, insulation class to IEC 60085: H \geq max. operating temperature 180 °C), color code black

Solderability: to IEC 60068-2-20, test Ta, method 1 (aging 3): 235 °C, 2 s

Resistance to soldering heat: to IEC 60068-2-20, test Tb, method 1B: 350 °C, 3,5 s

Winding: see page 152

Squared pins. For matching clamp and insulating washers see page 217.

Sections	A_N mm ²	l_N mm	A_R value $\mu\Omega$	Pins	Ordering code
1	15	30	69	4	B65808-N1004-D1
				5	B65808-N1005-D1
				6	B65808-N1006-D1
2	14	30	73	4	B65808-N1004-D2
				5	B65808-N1005-D2
				6	B65808-N1006-D2

4 pins

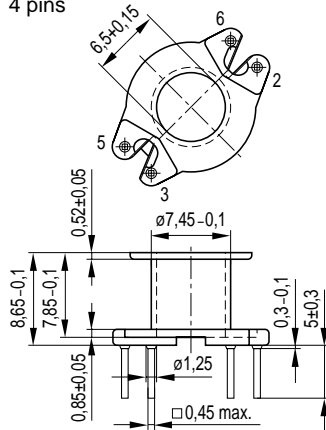

5 + 6 pins

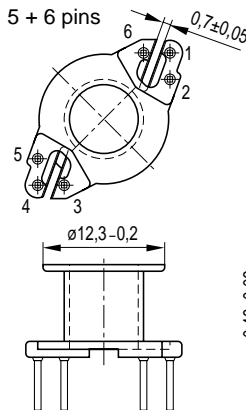

Pin 4 is omitted
in 5-pin version

Hole arrangement
View in mounting direction

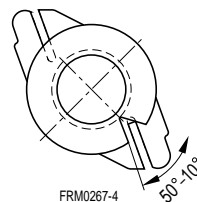
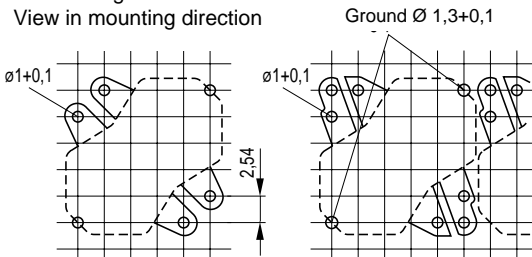

FRM0267-4

Coil former for SMPS transformers with line isolation

The creepage distances and clearances are designed such that the coil former is suitable for use in SMPS transformers with line isolation.

- Closed center flange with external wire guide
- Pins squared in the start-of-winding area
- Optimized for use with automatic winding machines

Material: GFR thermosetting plastic (UL 94 V-0, insulation class to IEC 60085:
F \geq max. operating temperature 155 °C), color code green

Solderability: to IEC 60068-2-20, test Ta, method 1 (aging 3): 235 °C, 2 s

Resistance to soldering heat: to IEC 60068-2-20, test Tb, method 1B: 350 °C, 3,5 s

Winding: see page 152

Sections	A_N mm ²	h_N mm	A_R value $\mu\Omega$	Pins	Ordering code
2	14	30	73	8	B65808-X1108-D2

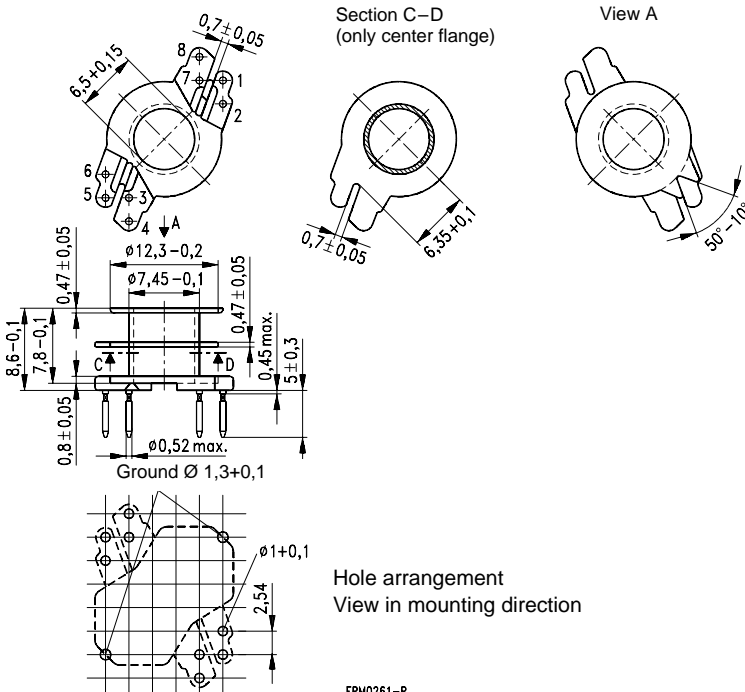

FRM0261-P

Coil former for power applications

Optimized for automatic winding

Material: GFR polyterephthalate (UL 94 V-0, insulation class to IEC 60085:

$F \triangleq$ max. operating temperature 155 °C), color code black

Solderability: to IEC 60068-2-20, test Ta, method 1 (aging 3): 235 °C, 2 s

Resistance to soldering heat: to IEC 60068-2-20, test Tb, method 1B: 350 °C, 3,5 s

Winding: see page 152

For matching clamp and insulating washer 1 see page 217

Sections	A_N mm ²	l_N mm	A_R value $\mu\Omega$	Pins	Ordering code
1	15	30	69	8	B65808-E1508-T1

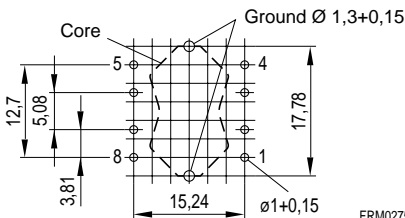
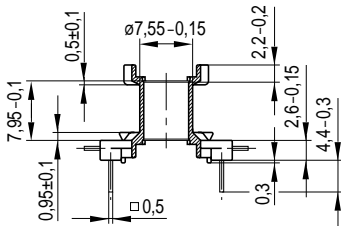
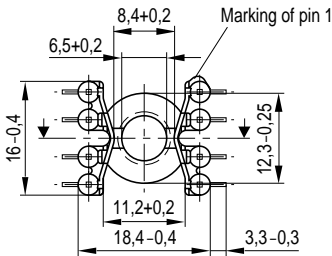

FRM0275-U

Clamp

- With ground terminal, made of stainless spring steel (tinned), 0,435 mm thick
- Solderability to IEC 60068-2-20, test Ta, method 1 (aging 3): 235 °C, 2 s
- Also available as strip clamp on reels

Insulating washer 1 between core and coil former

- For tolerance compensation and for insulation
- Made of polycarbonate (UL 94 V-0, insulation class to IEC 60085: E \geq 120 °C), 0,06 mm thick

Insulating washer 2 for double-clad PCBs

- Made of polycarbonate (UL 94 V-0, insulation class to IEC 60085: E \geq 120 °C), 0,3 mm thick

	Ordering code
Clamp (ordering code per piece, 2 are required)	B65808-A2203
Insulating washer 1 (reel packing, PU = 1 reel)	B65808-A5000
Insulating washer 2 (bulk)	B65808-C2005

Clamp

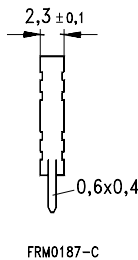
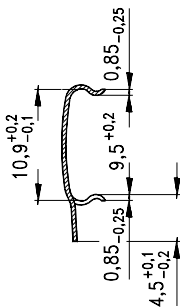

Insulating washer 1

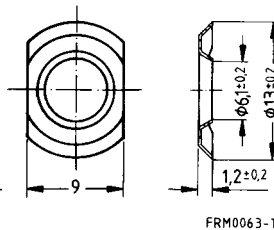

Insulating washer 2

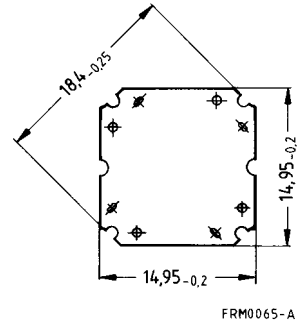

Clamping forces for RM 6

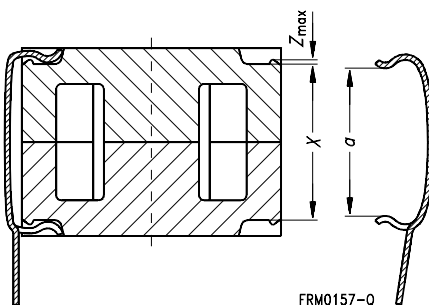

F_{min} : Extension of clamp from a to $a_2 = X_{min}$
 F_{max} : Extension of clamp from a to $a_1 = X_{max}$

Clamp opening a (mm)	9,5 + 0,2
Core nose Z_{max} (mm)	0,22
Height of core pair X (mm)	X_{min}
	X_{max}
Clamping force F (N)	F_{min}
	F_{max}

SMD coil former with gullwing terminals

Material: GFR liquid crystal polymer (UL 94 V-0, insulation class to IEC 60085:
F \triangleq max. operating temperature 155 °C), color code black

Solderability: to IEC 60068-2-20, test Ta, method 1 (aging 3): 235 °C, 2 s

Resistance to soldering heat: to IEC 60068-2-20, test Tb, method 1B: 350 °C, 3,5 s
permissible soldering temperature for wire-wrap connection on coil former: 400 °C, 1 s

Winding: see page 160

Clamp

- Without ground terminal, made of stainless spring steel, 0,3 mm thick
- Also available as strip clamp (each carton containing 2 reels)
- Also available on a reel on request

Sections	A _N mm ²	l _N mm	A _R value μΩ	Terminals	Ordering code
1	16,2	31	66	8	B65821-C1008-T1
2	15,2	31	69	8	B65821-C1008-T2
Clamp	(ordering code per piece, 2 are required)				B65808-J2204

Coil former

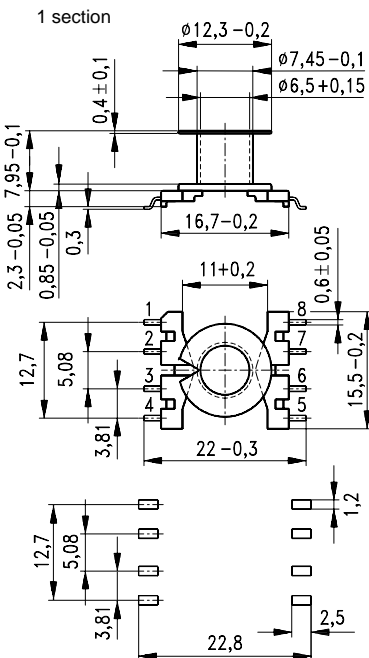

Clamp

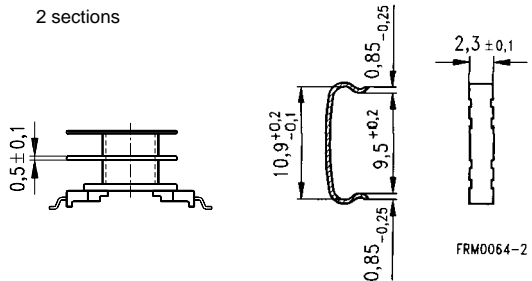

FRM0238-0

SMD coil former with J terminals

Material: GFR liquid crystal polymer (UL 94 V-0, insulation class to IEC 60085:
F \triangleq max. operating temperature 155 °C), color code black

Solderability: to IEC 60068-2-20, test Ta, method 1 (aging 3): 235 °C, 2 s

Resistance to soldering heat: to IEC 60068-2-20, test Tb, method 1B: 350 °C, 3,5 s
permissible soldering temperature for wire-wrap connection on coil former: 400 °C, 1 s

Winding: see page 160

Clamp

- Without ground terminal, made of stainless spring steel, 0,3 mm thick
- Also available as strip clamp (each carton containing 2 reels)
- Also available on a reel on request

Sections	A _N mm ²	l _N mm	A _R value μΩ	Terminals	Ordering code
1	16,2	31	66	8	B65821-J1008-T1
Clamp	(ordering code per piece, 2 are required)				B65808-J2204

Coil former

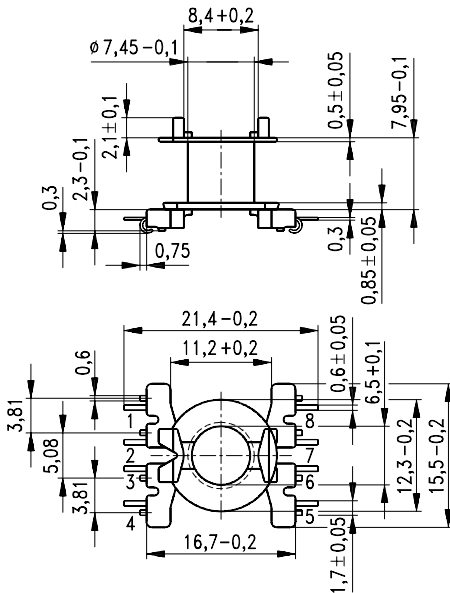

Clamp

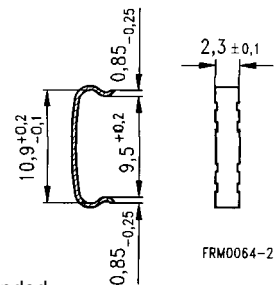

Recommended PCB layout

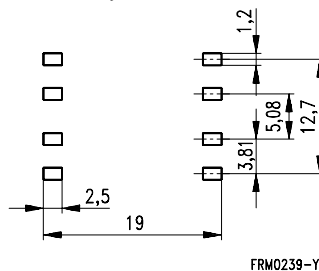

Adjusting screw

● Tube core with thread and core brake made of GFR polyterephthalate

Plastic **adjusting screwdriver** (not shown)

Plastic **handle** for adjusting screwdriver (not shown)

Core RM 6		Adjusting screw				Min. adjusting range %	Ordering code
Material	A _L value nH	Fig.	Tube core Ø × length mm	Material	Color code		
K 1	40	a	2,62 × 3,7	Si 1	white	15	B65659-F1-X101
M 33	63	a	2,62 × 3,7	Si 1	white	17	B65659-F1-X101
	100	c	2,82 × 4,4	Si 1	brown	16	B65659-F4-X101
N 48	160	a	2,62 × 3,7	K 1	green	17	B65659-F1-X1
	200	a	2,62 × 3,7	N 22	red	16	B65659-F1-X23
	250					11	
	315	b	2,75 × 4,4	N 22	black	13	B65659-F3-X23
400	c	2,82 × 4,4	N 22	yellow	11	B65659-F4-X23	
Adjusting screwdriver							B63399-B4
Handle							B63399-B5

Adjusting screws

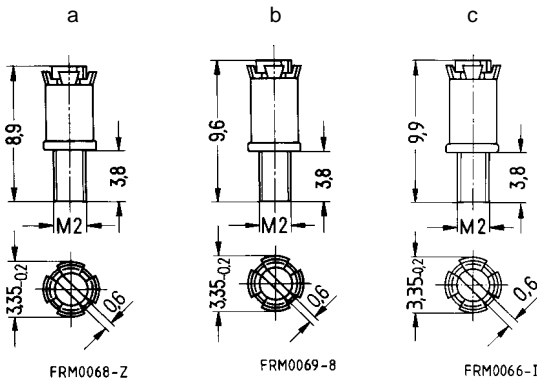

RM 6

Inductance adjustment curves (nominal values)

Relative inductance change $\Delta L/L$ versus turns N of adjusting screw.
 $0 \cong$ at least 1 turn engaged.

Adjusting screw B65659-F1-X101
 Color code white

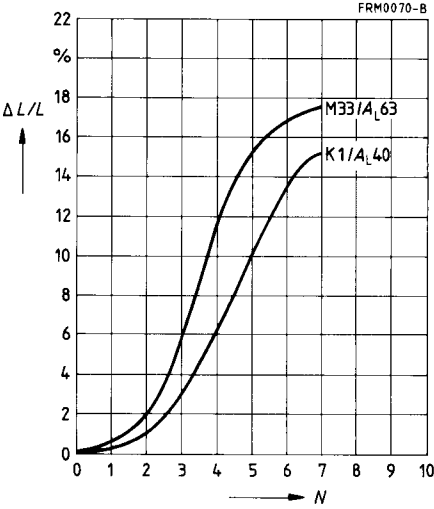

Adjusting screw B65659-F4-X101
 Color code brown

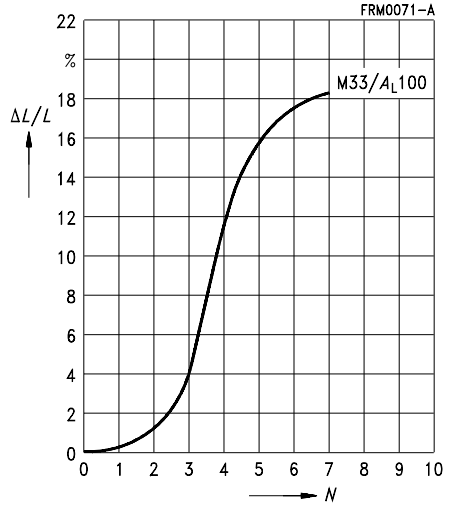

Adjusting screw B65659-F1-X1
 Color code green

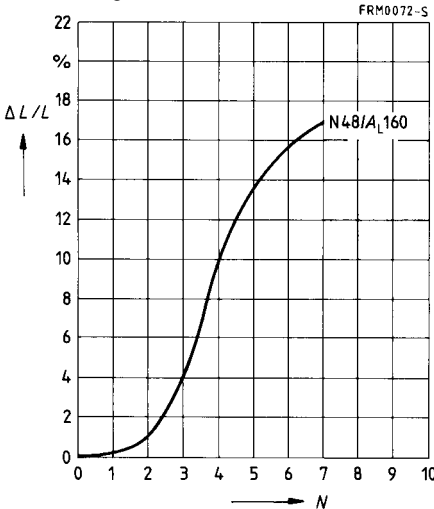

Adjusting screw B65659-F1-X23
 Color code red

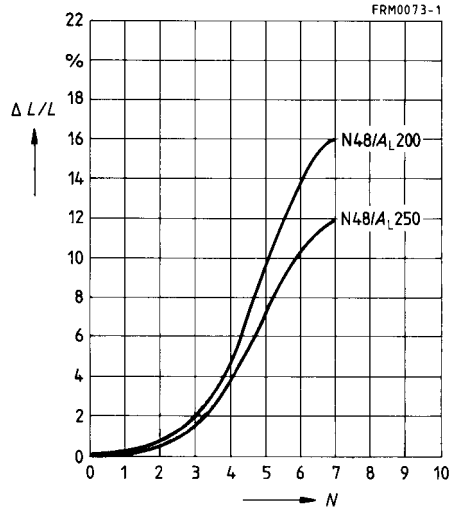

Inductance adjustment curves (nominal values)

Relative inductance change $\Delta L/L$ versus turns N of adjusting screw.

0 \cong at least 1 turn engaged.

Adjusting screw B65659-F3-X23

Color code black

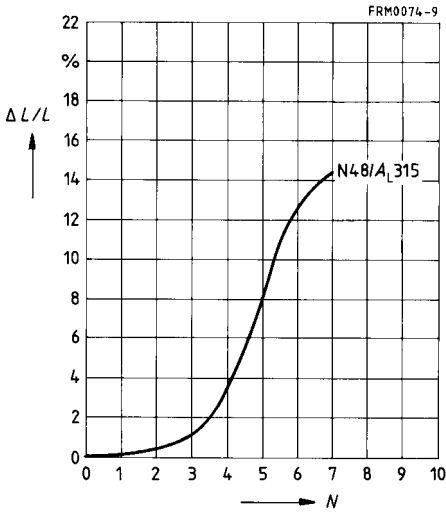

Adjusting screw B65659-F4-X23

Color code yellow

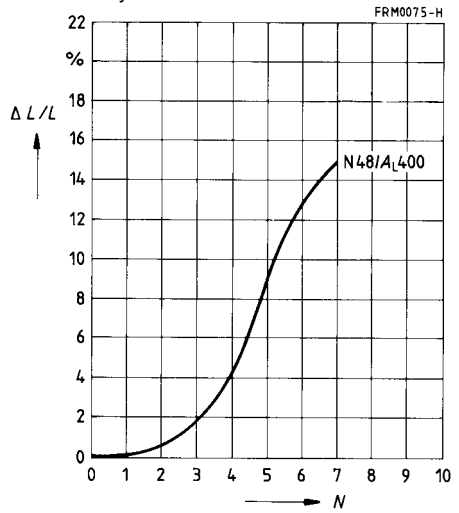

RM 6

Q factor characteristics (typical values)

Flux density in the core $\hat{B} < 2$ mT

Material	L (μ H) for		Turns	RF litz wire	Sec-tions	\varnothing^* mm
	$A_L = 63$ nH	$A_L = 100$ nH				
M 33	534	847	92	45 \times 0,04 CuLS	1	—
	414	657	81	45 \times 0,04 CuLS	2	—
	108	168	41	45 \times 0,04 CuLS	2	9,8
	49	75	27	45 \times 0,04 CuLS	2	10,6

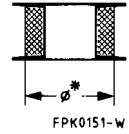

* Pad of polystyrene tape up to diameter \varnothing

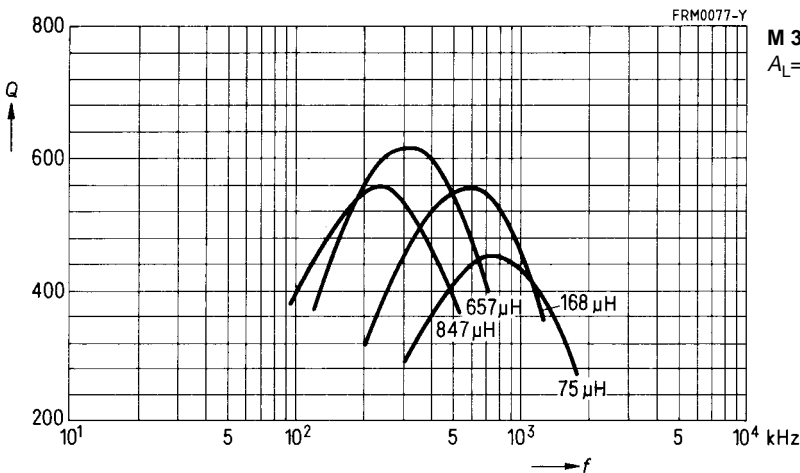
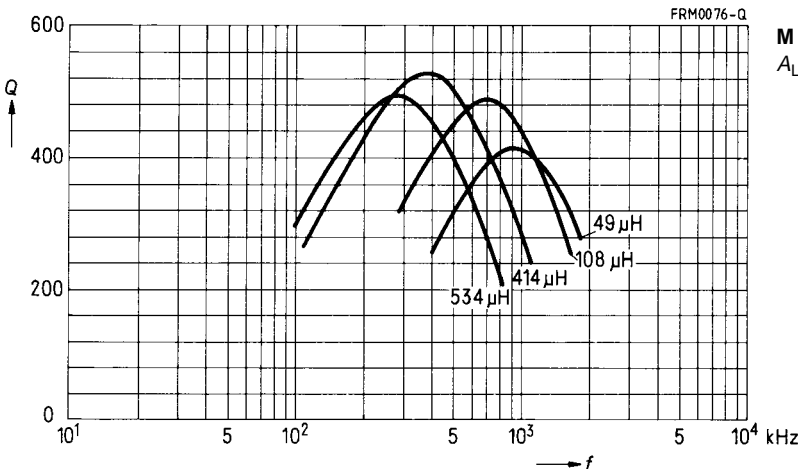

RM 6

Q factor characteristics (typical values)

Flux density in the core $\hat{B} < 2$ mT

Material	L (mH) for		Turns	Wire; RF litz wire	Sections
	$A_L = 250$ nH	$A_L = 315$ nH			
N 48	22,5	28,3	300	0,20 CuL	1
	12,1	15,2	220	6 × 0,07 CuLS	1
	4,55	5,73	135	20 × 0,05 CuLS	1

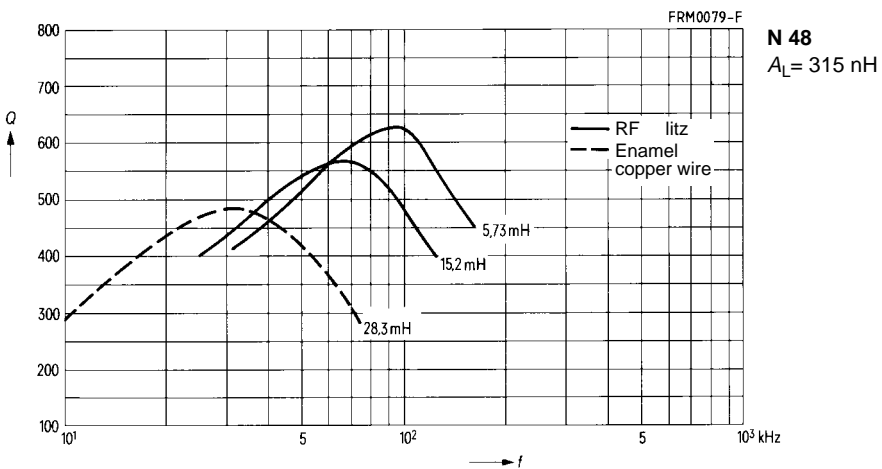
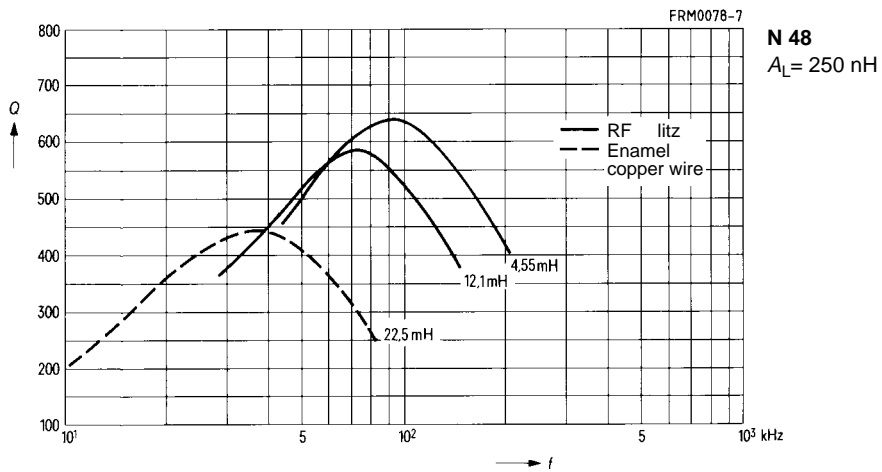

- For compact transformers
- Without center hole
- RM cores are supplied in sets

Magnetic characteristics (per set)

$\Sigma l/A = 0,58 \text{ mm}^{-1}$

$l_e = 21,8 \text{ mm}$

$A_e = 37,5 \text{ mm}^2$

$A_{\min} = 31,2 \text{ mm}^2$

$V_e = 820 \text{ mm}^3$

Approx. weight 4,0 g/set

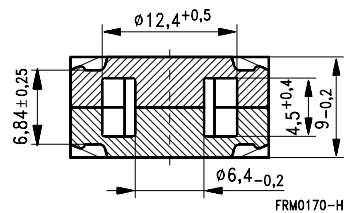
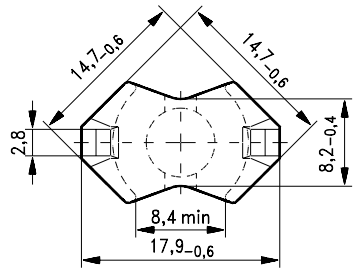

Ungapped

Material	A_L value nH	μ_e	$A_{L1\min}$	P_V W/set	Ordering code
T38	10500 + 40/- 30 %	4830			B65807-P-Y38
N49	2200 + 30/- 20 %	1020	1500	0,14 (50 mT, 500 kHz, 100 °C)	B65807-P-R49
N87	3000 + 30/- 20 %	1380	1950	0,40 (200 mT, 100 kHz, 100 °C)	B65807-P-R87

SMD coil former with gullwing terminals

Material: GFR liquid crystal polymer (UL 94 V-0, insulation class to IEC 60085:
F \triangleq max. operating temperature 155 °C), color code black

Solderability: to IEC 60068-2-20, test Ta, method 1 (aging 3): 235 °C, 2 s

Resistance to soldering heat: to IEC 60068-2-20, test Tb, method 1B: 350 °C, 3,5 s
permissible soldering temperature for wire-wrap connection on coil former: 400 °C, 1 s

Winding: see page 160

Clamp

- Without ground terminal, made of stainless spring steel, 0,3 mm thick
- Also available as strip clamp (each carton containing 2 reels)
- Also available on a reel on request

Sections	A _N mm ²	l _N mm	A _R value μΩ	Terminals	Ordering code
1	7,6	31	66	8	B65821-A6008-T1
Clamp	(ordering code per piece, 2 are required)				B65808-P2204

Coil former

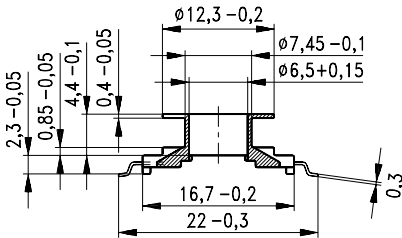

Clamp

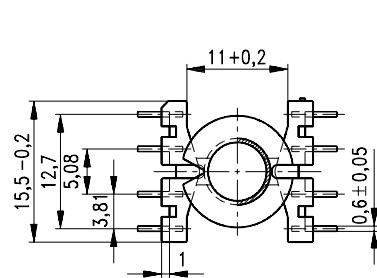
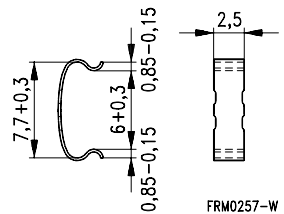

**Recommended
PCB layout**

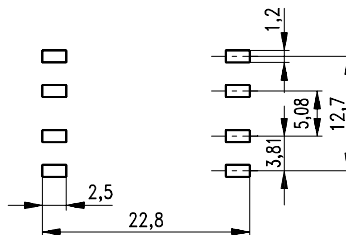

FRM0256-N