

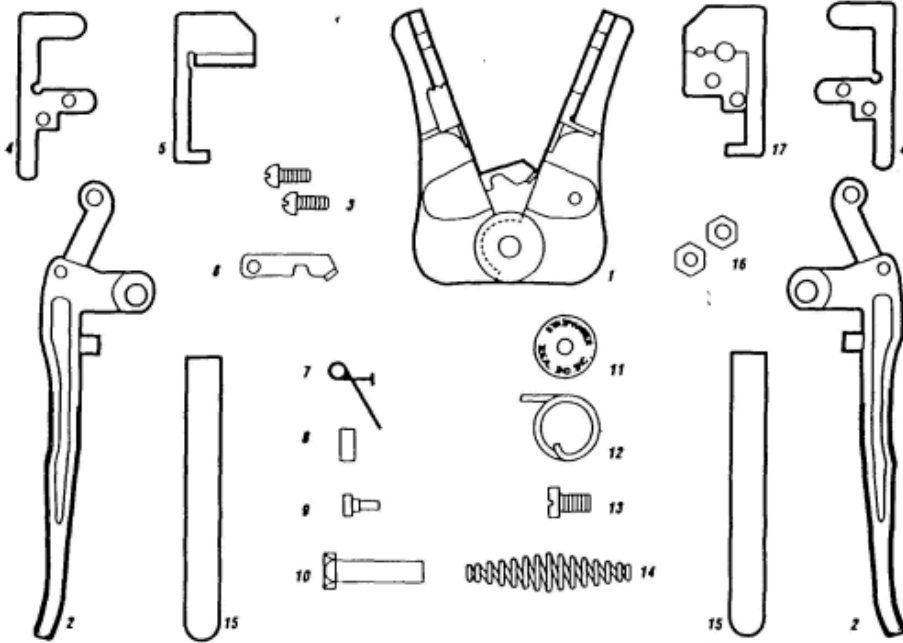

Stripmaster® Repair Parts List

Cat. No. 45-089, -090, -091, -092, -093, -095, -097, -098, -099



Please contact the factory for parts and repairs. Always include complete description, part number, and name plate data.

Parts List

Item	# Reqd	Description	Part No.
1	1	Jaw Sub-Assembly*	LB-1023
2	2	Handle Sub-Assembly	I-6757 RP
3	2	Gripper Screw (#5-40 x 13/32 w/lockwasher)	355.002
4	2	Retaining Plate, for blade and gripper	L-9040
5	1	Gripper, moving	K-1953
6	1	Latch	L-8906
7	1	Latch Spring	L-4388
8	1	Latch Pin	281.082
9	1	Latch Stud	L-8973
10	1	Pivot Stud	LB-909
11	1	Pivot Spring Cover	L-5093
12	1	Pivot Spring	L-5092
13	1	Pivot Stud Screw (#8-32 x 2/8, Nylok)	358.015
14	1	Handle Spring	L-4387
15	2	Handle Sleeve (Blue)	LA-4058
16	2	Blade Nut (#5-40, Keps Nut)	374.022
N/A	-	Complete Frame, less blades	L-5620
N/A	-	Accessory Wire Stop, adjustable	L-5270
17	1 pr	Blade Set (see table)	

Wire Size Stripping Hole Diameter

Cat. #	8	10	12	14	16	18	20	22	24	26	28	30	Part #
45-090	0.145	0.141	0.106										L-4419
45-091		0.144	0.105	0.085	0.073	0.073							L-4420
45-092		0.144	0.113	0.090	0.072	0.061	0.048	0.048					L-4421
45-093				0.090	0.072	0.061	0.039	0.039					L-4422
45-095	SP-SPT (I.e. LAMP CORD)											L-4452	
45-097					0.072	0.061	0.048	0.039					L-4994
45-098							0.048	0.039	0.032	0.026	0.021	0.016	L-5361
45-099	0.198	0.167			0.062	0.055							L-8763
45-089	European Flat Parallel Cable											L-8762	

Coax Stripmaster® Wire Strippers

Cat. #	Coax Cable Type (RGU)	Part #
45-262	RG-6	LB-740
45-264	RG-58	LB-742
45-265	RG-59	LB-743
45-266	RG-62	LB-744

*Jaw Sub-Assembly includes left and right jaws with items 6 through 10.

Caution

Never plug or mechanically gauge blade holes!

Operating Instructions

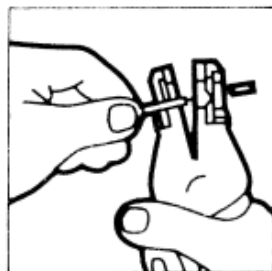
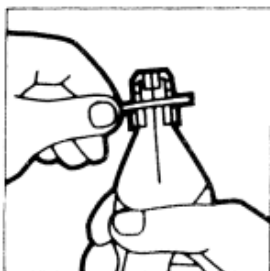

1. Insert wire between gripper jaws and position in proper blade hole.
2. Squeeze handles firmly with wire centered in hole to cut insulation.
3. Release pressure on handles and remove wire. Tool ready for next wire.
4. To ensure blade calibration, depress handles until blade surfaces mate. Tighten hex nuts (10 in./lbs). Sample strip. Repeat if necessary.

Maintenance

1. Keep tool clean and free from debris.

2. Insulation material may be removed by washing in cleaning solvent.
3. Apply a light oil to moving parts.

IDEAL INDUSTRIES, INC., Sycamore, IL 60178 U.S.A.
in Canada: IDEAL, Ajax, Ontario L1S 2E1
www.idealindustries.com

©2014 IDEAL INDUSTRIES, INC. All rights reserved.