

HDSP-431G/433G

10 mm Three Digit Slim Font with 2-Colons
Seven Segment Displays

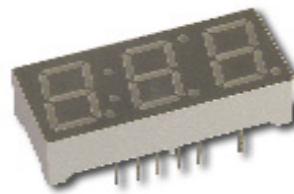

Data Sheet



Description

The 10 mm (0.4 inch) Three Digit Slim Font with 2-Colons Seven Segment Displays incorporates a new slim font character design. This slim font features narrow width, specially mitered segments to give a fuller appearance to the illuminated character. Faces of these displays are painted a neutral gray for enhanced on/off contrast.

All devices are available in either common anode or common cathode configuration with tinted green segments.

Devices

Green	Description
HDSP-431G	3 Digit, Common Anode, Untinted-Diffused, 0.4" Display
HDSP-433G	3 Digit, Common Cathode, Untinted-Diffused, 0.4" Display

Features

- Excellent appearance
- Slim font design
- Mitered corners, evenly illuminated segments
- Gray face for optimum on/off contrast
- Choice of colors: green
- Choice of character size: 10 mm (0.4 inch)
- Characterized for luminous intensity

Part Numbering System

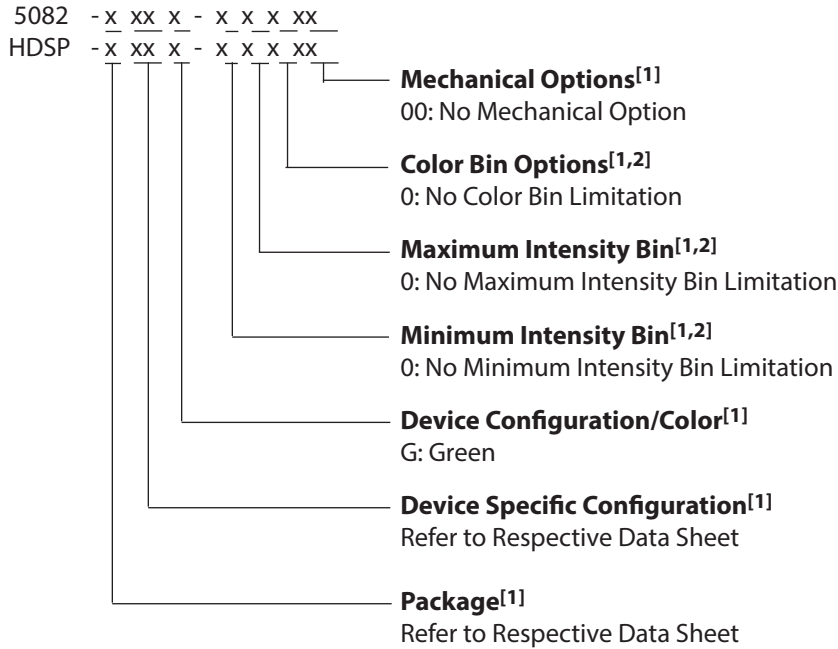

Notes:

1. For codes not listed in the figure above, please refer to the respective data sheet or contact your nearest Avago representative for details.
2. Bin options refer to shippable bins for a part-number. Color and Intensity Binbs are typically restricted to 1 bin per tube (exceptions may apply). Please refer to respective data sheet for specific bin limit information.

Package Dimensions

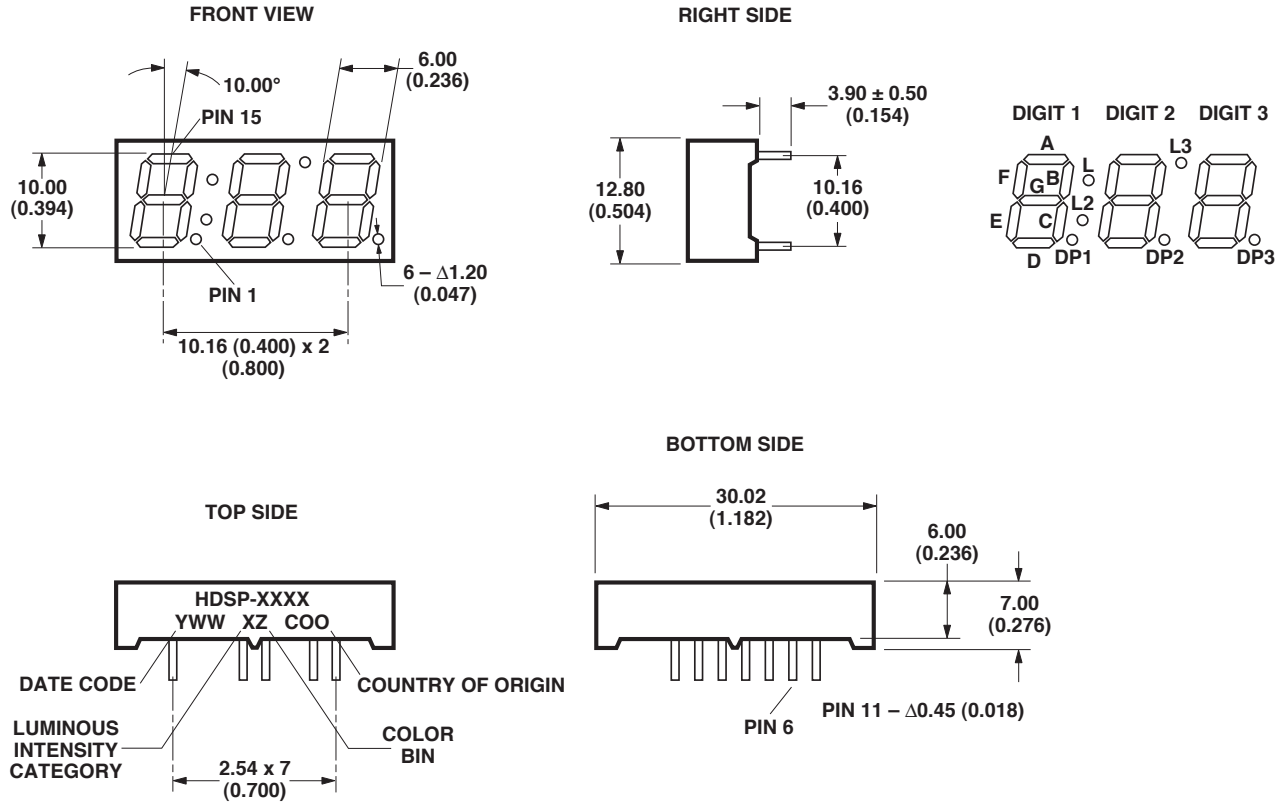

NOTES:

1. ALL DIMENSIONS ARE IN MILLIMETERS (INCHES).
2. UNLESS OTHERWISE STATED, TOLERANCES ARE $\pm 0.25\text{mm}$

Pin	Function
1	Digit 1 Common A/C
2	E
3	C
4	D
5	Digit 2 Common A/C
6	DP
7	Digit 3 Common A/C
8	G
9	No pin
10	No pin
11	B
12	A
13	No pin
14	L1, L2, & L3 Common A/C
15	FPIN

Internal Circuit Diagram (Common Cathode)

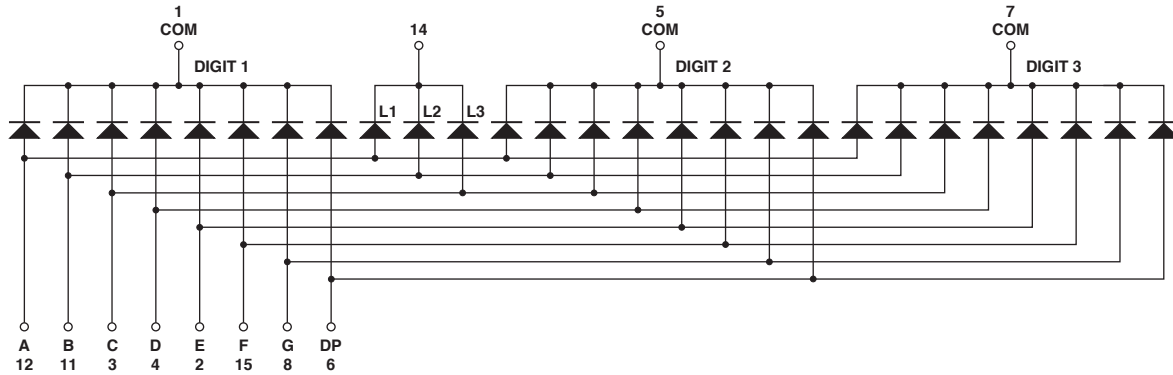

Internal Circuit Diagram (Common Anode)

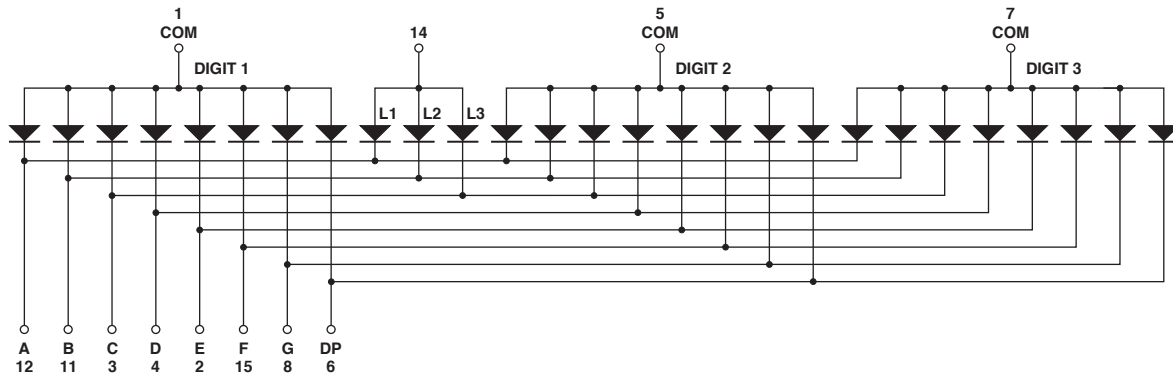

Absolute Maximum Ratings at $T_A = 25^\circ\text{C}$

Description	Green	Units
Average Power per Segment or DP	65	mW
Peak Forward Current per Segment or DP	100	mA
DC Forward Current per Segment or DP	25	mA
Operating Temperature Range	-40 to +105	$^\circ\text{C}$
Storage Temperature Range	-40 to +105	$^\circ\text{C}$
Reverse Voltage per Segment or DP	3	V
Wave Soldering Temperature for 3 Seconds 1.59 mm below Body	250	$^\circ\text{C}$

Note:

1. Derate above 40°C at $0.33\text{ mA}/^\circ\text{C}$ for Green.

Electrical/Optical Characteristics at $T_A = 25^\circ\text{C}$

Device Series	Parameter	Symbol	Min.	Typ.	Max.	Units	Test Conditions
HDSP-431G/ HDSP-433G	Luminous Intensity/ Segment (Digit Average)	I_V	3.200	5.000		mcd	$I_F = 10\text{ mA}$
	Forward Voltage/ Segment or DP	V_F		2.25	2.50	V	$I_F = 20\text{ mA}$
	Peak Wavelength	λ_{PEAK}		568		nm	$I_F = 20\text{ mA}$
	Dominant Wavelength	λ_d		573		nm	$I_F = 20\text{ mA}$
	Reverse Current	I_R			100	μA	$V_R = 5\text{ V}$

Notes:

1. Typical specification for reference only. Do not exceed absolute maximum ratings.
2. The dominant wavelength, λ , is derived from the CIE chromaticity diagram and is that single wavelength which defines the color of the device.

Intensity Bin Limits (mcd)

Green

HDSP-431G/433G		
IV Bin Category	Min.	Max.
L	3.200	5.050
M	5.051	8.000

Color Categories

Color	Bin	Dominant Wavelength (nm)	
		Min.	Max.
Green	3	570.0	574.0
	4	567.0	571.0

Note:

- All categories are established for classification of products. Products may not be available in all categories. Please contact your Avago representatives for further clarification/information.

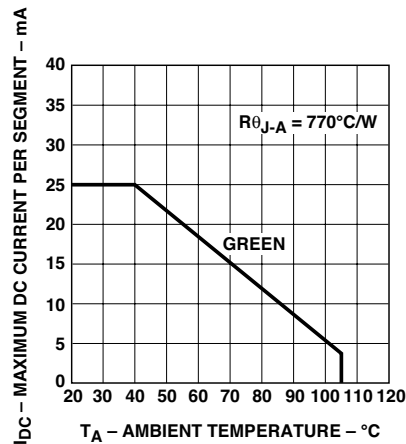

Figure 1. Maximum allowable DC current vs. ambient temperature

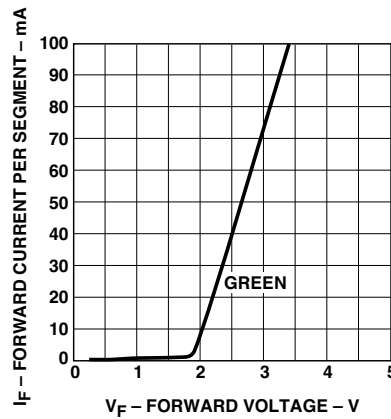

Figure 2. Forward current vs. forward voltage

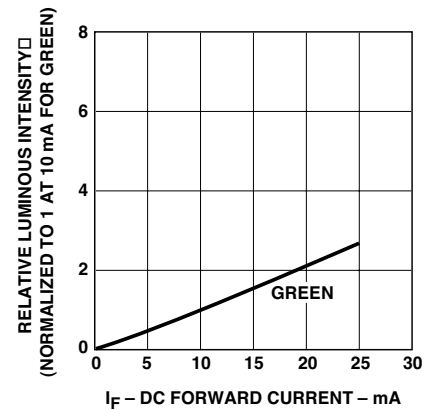

Figure 3. Relative luminous intensity vs. DC forward current

Contrast Enhancement

For information on contrast enhancement, please see Application Note 1015.

Soldering/Cleaning

Cleaning agents from the ketone family (acetone, methyl ethyl ketone, etc.) and from the chlorinated hydrocarbon family (methylene chloride, trichloroethylene, carbon tetrachloride, etc.) are not recommended for cleaning LED parts. All of these various solvents attack or dissolve the encapsulating epoxies used to form the package of plastic LED parts.

For information on soldering LEDs, please refer to Application Note 1027.

For product information and a complete list of distributors, please go to our website: www.avagotech.com

Avago, Avago Technologies, and the A logo are trademarks of Avago Technologies in the United States and other countries. Data subject to change. Copyright © 2005-2013 Avago Technologies. All rights reserved. Obsoletes 5989-4063EN AV02-0130EN - January 16, 2013

AVAGO
TECHNOLOGIES