

Operating Instructions

Edition May 2010

The DEC Module 24/2 (Digital EC Controller) is a small 1-quadrant digital controller for the control of brushless DC motors (Electronic Commutated motors) up to 48 W. The used EC motor must be equipped with digital Hall sensors.

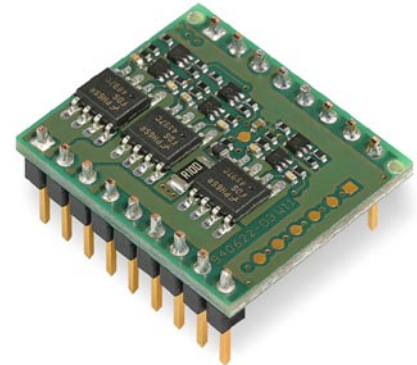

Features:

- Digital speed control operates as «closed loop» or as «open loop» speed controller
• Maximum speed 80 000 rpm (motor with 1 pole pair)
• Set value input through external analogue voltage (0 ... +5 V)
• 3 different speed ranges selectable
• Direction of rotation preset by a digital signal
• The output stage can be enabled or disabled
• Maximum output current limit adjustable up to 3 A
• Status indication via «Ready» output
• Blockage protection (current limit for blocked motor)
• Protective functions: undervoltage, overvoltage and thermal overload
• Standardized connector strip, pitch 2.54 mm

Thanks to the wide input power supply range of 8...24 VDC (optional 5 VDC operation possible), the DEC Module 24/2 is very versatile and can be used with various power supplies.

A sturdy PI speed controller design is an ideal premise for immediate operation.

The well-priced and miniaturized OEM module seamlessly integrates into applications. Now the customer can fully focus on developing his/hers own device - while being able to make use of maxon motor's vast drive know-how. For start-up maxon motor offers a comprehensive Evaluation Board.

Table of Contents

1 Safety Instructions 2
2 Technical Data 3
3 Pin assignment DEC Module 24/2..... 4
4 Commissioning Instructions..... 5
5 Functional Description of Inputs and Outputs..... 6
6 Protective functions 11
7 Block Diagram 12
8 Dimensional Drawing..... 13
9 Accessories (not included in delivery) 13
10 Appendix «Motherboard Design Guide» 13

The latest edition of these operating instructions may be downloaded from the internet as a PDF-file under www.maxonmotor.com, category «Service & Downloads», order number 367661 or in the e-shop http://shop.maxonmotor.com.

1 Safety Instructions

**Skilled Personnel**

Installation and starting of the equipment shall only be performed by experienced, skilled personnel.

**Statutory Regulations**

The user must ensure that the amplifier and the components belonging to it are assembled and connected according to local statutory regulations.

**Load Disconnected**

For primary operation the motor should be free running, i.e. with load disconnected.

**Additional Safety Equipment**

Any electronic apparatus is, in principle, not fail-safe. Machines and apparatus must therefore be fitted with independent monitoring and safety equipment. If the equipment breaks down, if it is operated incorrectly, if the control unit breaks down or if the cables break, etc., it must be ensured that the drive or the complete apparatus is kept in a safe operating mode.

**Repairs**

Repairs may be made by authorized personnel only or by the manufacturer. Improper repairs can result in substantial dangers for the user

**Danger**

During installation of the DEC Module, make sure to disconnect all apparatus from the electrical supply.

After switch-on, do not touch any life parts!

**Wiring Procedure**

All cable connections should only be connected or disconnected when the power is switched off.

**Max. Supply voltage**

Make sure that the supply voltage is between 8 and 28 VDC. Voltage higher than 30 VDC or wrong polarity will destroy the unit.

**Short Circuit and Earth Fault**

The amplifier is not protected against winding short circuits against ground safety earth and/or GND!

**Electrostatic sensitive device (ESD)**

2 Technical Data

2.1 Electrical data

Nominal supply voltage $+V_{CC}$	8 ... 24 VDC (optional 5 VDC ¹)
Absolute minimum supply voltage $+V_{CC \text{ min}}$	8 VDC (optional 5 VDC ¹)
Absolute maximum supply voltage $+V_{CC \text{ max}}$	28 VDC
Max. output voltage	$+V_{CC}$
Continuous output current I_{cont}	2 A
Max. output current I_{max}	3 A
Switching frequency	46.8 kHz
Max. speed (motor with 1 pole pair)	80 000 rpm

2.2 Inputs

«Set value speed»	Analogue input (0 ... 5 V); Resolution: 1024 steps
«Enable»	+2.4 ... +28 V ($R_1 = 100 \text{ k}\Omega$) or switch against V_{CC}
«Direction»	+2.4 ... +28 V ($R_1 = 100 \text{ k}\Omega$) or switch against V_{CC}
Speed range «DigIN1 »	+2.4 ... +28 V ($R_{\text{pull-up}} = 15 \text{ k}\Omega$ at 5 V) or switch against Gnd
Speed range «DigIN2 »	+2.4 ... +28 V ($R_{\text{pull-up}} = 15 \text{ k}\Omega$ at 5 V) or switch against Gnd
«Set current limit»	external resistor ($\frac{1}{16} \text{ W}$) against Gnd
Hall sensors	«Hall sensor 1», «Hall sensor 2», «Hall sensor 3»

2.3 Output

Status indication «Ready»	Digital output signal, 5 V ($R_1 = 10 \text{ k}\Omega$)
---------------------------	---

2.4 Voltage output

+5 VDC output voltage « $V_{CC \text{ Hall}}$ »	+5 VDC, max. 35 mA
---	--------------------

2.5 Motor connections

Motor connections	«Motor winding 1», « Motor winding 2», « Motor winding 3»
-------------------	---

2.6 Ambient temperature

Operation	-10 ... +45°C
Storage	-40 ... +85°C

2.7 Humidity range

Non condensating	20 ... 80 %
------------------	-------------

2.8 Protective functions

Current limitation (cycle-by-cycle)	adjustable up to maximum 3 A
Blockage	Motor current limitation if motor shaft is blocked for longer than 1.5 s
Undervoltage shutdown	shutdown if $V_{CC} < 6.5 \text{ VDC}$
Overvoltage shutdown	shutdown if $V_{CC} > 30 \text{ VDC}$
Thermal overload protection of power stage	shutdown if $T_{\text{power stage}} > 95^\circ\text{C}$

2.9 Mechanical data

Weight	approx. 4 g
Dimensions (LxWxH)	24.2 x 20.38 x 12.7 mm
	0.95 x 0.8 x 0.5 Inch

2.10 Terminals

Pin header 1	9 poles
	single row, pitch 2.54 mm (0.1 Inch)
Pin header 2	8 poles
	single row, pitch 2.54 mm (0.1 Inch)

¹ 5V operating see chapter «10.8.2 Low Voltage +5V operation»

3 Pin assignment DEC Module 24/2

Top view

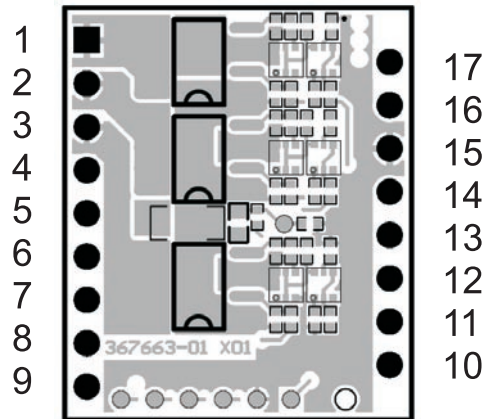

3.1 Pin assignment

Pin	Signal	Description
1	W1	Motor winding 1
2	W2	Motor winding 2
3	W3	Motor winding 3
4	+V _{CC}	Supply voltage 8...24 VDC
5	Gnd	Ground
6	V _{CC} Hall	+5 VDC output voltage
7	H1	Hall sensor 1
8	H2	Hall sensor 2
9	H3	Hall sensor 3

Pin	Signal	Description
17	Set value speed	Set value speed input
16	Set current limit	Set current limit input
15	Gnd	Ground
14	Direction	Direction input
13	Enable	Enable input
12	DigIN2	Digital input 2
11	DigIN1	Digital input 1
10	Ready	Status indication output

4 Commissioning Instructions

4.1 Power supply layout

Any available power supply can be used, as long as it meets the minimum requirements shown below.

During set up and adjustment phases, we recommend to mechanically separate the motor from the machine to prevent damage due to uncontrolled motion!

Power supply requirements

Nominal output voltage	8 VDC < V_{CC} < 24 VDC
Absolute minimum output voltage	8 VDC
Absolute maximum output voltage	28 VDC
Output current	depending on load, continuous max. 2 A acceleration, short-time max. 3 A

The required supply voltage can be calculated as follows:

Known values

- ⇒ Operating torque M_B [mNm]
- ⇒ Operating speed n_B [rpm]
- ⇒ Nominal motor voltage U_N [V]
- ⇒ Motor no-load speed at U_N , n_0 [rpm]
- ⇒ Speed/torque gradient of the motor $\Delta n/\Delta M$ [rpm/mNm]

Sought value

- ⇒ Supply voltage V_{CC} [V]

Solution

$$V_{CC} = \frac{U_N}{n_0} \cdot \left(n_B + \frac{\Delta n}{\Delta M} \cdot M_B \right) + 0.5V$$

Select a power supply capable of supplying this calculated voltage under load. The formula takes into account a 0.5 V maximum voltage drop (at maximum output current) of the power stage.

What speed can be reached with a given power supply:

$$n_B = \left[(V_{CC} - 0.5V) \cdot \frac{n_0}{U_N} \right] - \left[\frac{\Delta n}{\Delta M} \cdot M_B \right]$$

Note

- ⇒ The power supply must be able to buffer the back-fed energy e.g. in a capacitor.
- ⇒ The under voltage protection switches off the DEC Module 24/2, as soon as the supply voltage V_{CC} falls below 6.5 V. Therefore, at low supply voltage V_{CC} attention has to be paid to the voltage drop over the supplying cables.

5 Functional Description of Inputs and Outputs

5.1 Inputs

5.1.1 Speed range and mode selection with «DigIN1» und «DigIN2»

The digital inputs «DigIN1» [11] and «DigIN2» [12] determine both, the operation mode (digital speed controller or digital speed actuator) and the speed range in speed set value mode.

DigIN1	DigIN2	Motor type		
		1 pole pair	4 pole pair	8 pole pair
0	0	Open loop speed control, 0...100 % PWM depending on the «Set value speed» input voltage		
1	0	500...5 000 rpm	125...1 250 rpm	62...625 rpm
0	1	500...20 000 rpm	125... 5 000 rpm	62...2 500 rpm
1	1	500...80 000 rpm	125...20 000 rpm	62...10 000 rpm

Please note

⇒ If the signal level of the digital inputs DigIN1 [11] and DigIN2 [12] are changed, the new levels are adopted by a disable-enable procedure.

If the input «DigIN» is not connected (floating) or a voltage higher than 2.4 V is applied, the input is active.

Logic 1	Input not connected (floating) Input voltage > 2.4 V	Input active
---------	---	--------------

If the input «DigIN» is set to ground potential or a voltage smaller than 0.8 V is applied, the digital input is inactive

Logic 0	Input set to Gnd Input voltage < 0.8 V	Input inactive
---------	---	----------------

The inputs «DigIN1» and «DigIN2» are protected against over voltage.

Digital input 1	Pin number [11] «DigIN1»
Digital input 2	Pin number [12] «DigIN2»
Input voltage range	0 ... +5 V
Input impedance	15 kΩ pull-up resistor against 5 V
Continuous over voltage protection	-28 ... +28 V

5.1.2 Set value «Set value speed»

The external analogue set value is predetermined at the «Set value speed» input [17]. The «Set value speed» input sets the rotational speed of the motor shaft.

By adjusting the signal levels on digital inputs «DigIN1 [11]» and «DigIN2 [12]» the speed range can be set in advance.

		Motor type		
DigIN1	DigIN2	1 pole pair	4 pole pair	8 pole pair
0	0	Open loop speed control, 0...100 % PWM depending on the «Set value speed» input voltage		
1	0	500...5 000 rpm	125...1 250 rpm	62...625 rpm
0	1	500...20 000 rpm	125...5 000 rpm	62...2 500 rpm
1	1	500...80 000 rpm	125...20 000 rpm	62...10 000 rpm

Note

- ⇒ If the signal level of the digital inputs DigIN1 [11] and DigIN2 [12] are changed, the new levels are adopted by a disable-enable procedure.

Set value voltage	Description
0 V ... 0.1 V	Operation at a minimum speed
0.1 V ... 5.0 V	Linear speed adjustment

The actual speed value is calculated according the following formula:

Known values

- ⇒ Minimum speed (see table above) n_{\min} [rpm]
 ⇒ Maximum speed (see table above) n_{\max} [rpm]
 ⇒ Set value voltage V_{set} [V] respectively speed n [rpm]

Sought value

- ⇒ speed n [rpm]

Solution

$$n = \left[\frac{V_{\text{set}} - 0.1[V]}{4.9[V]} \cdot (n_{\max} - n_{\min}) \right] + n_{\min}$$

Sought value

- ⇒ Set value voltage V_{set} [V]

Solution

$$V_{\text{set}} = \left(\frac{n - n_{\min}}{n_{\max} - n_{\min}} \cdot 4.9[V] \right) + 0.1[V]$$

The «Set value speed» input is protected against over voltage.

Set value speed input	Pin number [17] «Set value speed»
Input voltage range	0 ... +5 V (referenced to Gnd)
Resolution	1024 steps (4.88 mV)
Input impedance	107 kΩ (in range 0 ... +5 V)
Continuous over voltage protection	-28 ... +28 V

5.1.3 «Enable»

The «Enable» input enables or disables the power stage.

If a voltage higher than 2.4 V is applied to the «Enable» input, the amplifier is activated (Enable). A speed ramp will be performed during acceleration.

Enable	Input voltage > 2.4 V	Motor shaft running
--------	-----------------------	---------------------

If the input is not connected (floating) or ground potential is applied to the «Enable» input, the power stage is high impedant and the motor shaft free-wheels and slows down (Disable).

Disable	Input not connected (floating) Input set to Gnd Input voltage < 0.8 V	Power stage switched off
---------	---	--------------------------

The «Enable» input is protected against overvoltage.

Enable	Pin number [13] «Enable»
Input voltage range	0 ... +5 V
Input impedance	100 k Ω (in range 0 ... +5 V)
Continuous over voltage protection	-28 ... +28 V
Delay time	max. 20 ms

Note

⇒ If the signal level of the digital inputs DigIN1 [11] and DigIN2 [12] are changed, the new levels are adopted by a disable-enable procedure.

5.1.4 «Direction»

The «Direction» input determines the rotational direction of the motor shaft. When the level changes, the motor shaft slows down with a ramp to standstill, and accelerates with a speed ramp in the opposite direction, until the nominal speed is reached again.

If the input is not connected (floating) or ground potential is applied to the «Direction» input, the motor shaft runs clockwise (CW).

CW	Input not connected (floating) Input set to Gnd Input voltage < 0.8 V	Clockwise (CW)
----	---	----------------

If a voltage higher than 2.4 V is applied to the «Direction» input, the motor shaft runs counter-clockwise (CCW).

CCW	Input voltage > 2.4 V	Counter-clockwise (CCW)
-----	-----------------------	-------------------------

The «Direction» input is protected against overvoltage.

Direction	Pin number [14] «Direction»
Input voltage range	0 ... +5 V
Input impedance	100 k Ω (in range 0 ... +5 V)
Continuous over voltage protection	-28 ... +28 V

5.1.5 «Set current limit»

The «Set current limit» inputs is used for setting the continuous output current limitation in the range of 0.5...3 A.

The current applied at the input «Set current limit» will stay available for an indefinite period of time.

Note

- ⇒ The limiting value should be below the rated motor current (max. continuous current) as shown on the motor data sheet (corresponds to line 6 in maxon catalogue).

Set value current	Pin number [16] «Set current limit»
Referenced to Ground	Pin number [15] «Gnd»

To parameterize the preferred current limiting value, an external resistor (at least 62.5 mW) between current limiting input «Set current limit» Pin [16] and ground «Gnd» Pin [15] must be added.

Current limit value	Resistance value (E12 series)
3.0 A	input floating
2.5 A	47 kΩ
2.0A	10 kΩ
1.5 A	4.7 kΩ
1.0 A	2.2 kΩ
0.5 A	470 Ω

Note

- ⇒ Under unfavourable circumstances the actual motor peak current can not be limited to the set current limit in all cases.
Unfavourable circumstances are given, if the current limit value is set lower than 1.5 A, the supply voltage is higher than 15 V an the terminal inductance is smaller than 0.3 mH at the same time.

5.1.6 «Hall sensor 1», «Hall sensor 2», «Hall sensor 3»

Hall sensors are needed for detecting rotor position and actual speed.

The Hall sensor inputs are protected against overvoltage.

Hall sensor 1	Pin number [7] «Hall sensor 1»
Hall sensor 2	Pin number [8] «Hall sensor 2»
Hall sensor 3	Pin number [9] «Hall sensor 3»
Input voltage range	0 ... +5 V
Input impedance	10 kΩ pull-up resistor to 5 V
Voltage level «low»	max. 0.8 V
Voltage level «high»	min. 2.4 V
Continuous over voltage protection	-28 ... +28 V

Suitable for Hall sensor IC's with Schmitt-Trigger behavior and open collector outputs.

5.2 Outputs

5.2.1 +5 VDC output voltage «V_{CC} Hall»

An internal auxiliary voltage of +5 VDC is provided for:

- ⇒ Hall sensor supply voltage «V_{CC} Hall»
- ⇒ For external set value potentiometer (recommended value: 10 kΩ)
- ⇒ Gating the signals: «Enable» and «Direction»

The output is thermal overload protected against short circuit.

+5 VDC output voltage	Pin number [6] «V _{CC} Hall»
Referenced to Ground	Pin number [5] «Gnd»
Output voltage	+5 VDC ± 5 %
Max. output current	35 mA

5.2.2 Status indication «Ready»

The «Ready» output can be used to report the state of operational readiness or a fault condition to a master control unit.

In normal cases (no fault) the output is switched to 5V.

Ready (no fault)	5 V
------------------	-----

In case of a fault the output is switched to Ground.

Fault (not ready)	0 V (Gnd)
-------------------	-----------

Possible reason for a fault message:

- ⇒ **Undervoltage**
Fault message occurs in case supply voltage $+V_{CC} < 6.5$ VDC.
To reset the fault condition the amplifier must be disabled and the supply voltage $+V_{CC}$ must be higher than 6.5 VDC.
- ⇒ **Overvoltage**
Fault message occurs in case supply voltage $+V_{CC} > 30$ VDC.
To reset the fault condition the amplifier must be disabled and the supply voltage $+V_{CC}$ must be lower than 29 VDC.
- ⇒ **Thermal overload**
Fault message occurs in case power stage temperature exceeds $> 95^{\circ}\text{C}$.
To reset the fault condition the amplifier must be disabled and the power stage temperature must fall below 75°C
- ⇒ **Invalid Hall sensor signals**
The amplifier recognizes invalid conditions in the Hall sensor inputs during the power-up. To reset the fault condition the amplifier must be disabled and the Hall sensors must be wired correctly.

The output «Ready» is protected against short circuit.

Status indication	Pin number [12] «Ready»
Output voltage range	0 ... +5 V
Output resistance	10 kΩ

6 Protective functions

6.1 Undervoltage protection

The power stage will be disabled in case the supply voltage $+V_{CC}$ gets lower than 6.5 VDC.

To reset the fault condition the amplifier must be disabled and the supply voltage $+V_{CC}$ must be higher than 6.5 VDC.

6.2 Overvoltage protection

The power stage will be disabled in case the supply voltage $+V_{CC}$ gets higher than 30 VDC.

To reset the fault condition the amplifier must be disabled and the supply voltage $+V_{CC}$ must be lower than 29 VDC.

6.3 Thermal overload protection

The power stage will be disabled in case the power stage temperature exceeds higher than 95°C.

To reset the fault condition the amplifier must be disabled and the power stage temperature must fall below 75°C.

6.4 Invalid Hall sensor signals

The power stage will be disabled in case invalid conditions in the Hall sensor inputs during the power-up occurs.

To reset the fault condition the amplifier must be disabled and the Hall sensors must be wired correctly.

6.5 Blockage protection

If the motor shaft is blocked for longer than 1.5 s, the current limit is set at 2.5 A, provided the current limit was not set lower via «Set current limit» input.

Definition «Motor shaft blocked»: A lower speed than 400 rpm (motor with 1 pole pair) occurs for longer than 1.5 s.

Note

⇒ No fault message occurs at the «Ready» output if blockage protection is active.

6.6 Current limitation

The motor current will be restricted to 0.5...3 A depending on the value applied to the input «Set current limit» by means of a cycle-to-cycle limitation (see chapter [«5.1.5 «Set current limit»»](#)).

Note

⇒ No fault message occurs at the «Ready» output if current limitation is active.

7 Block Diagram

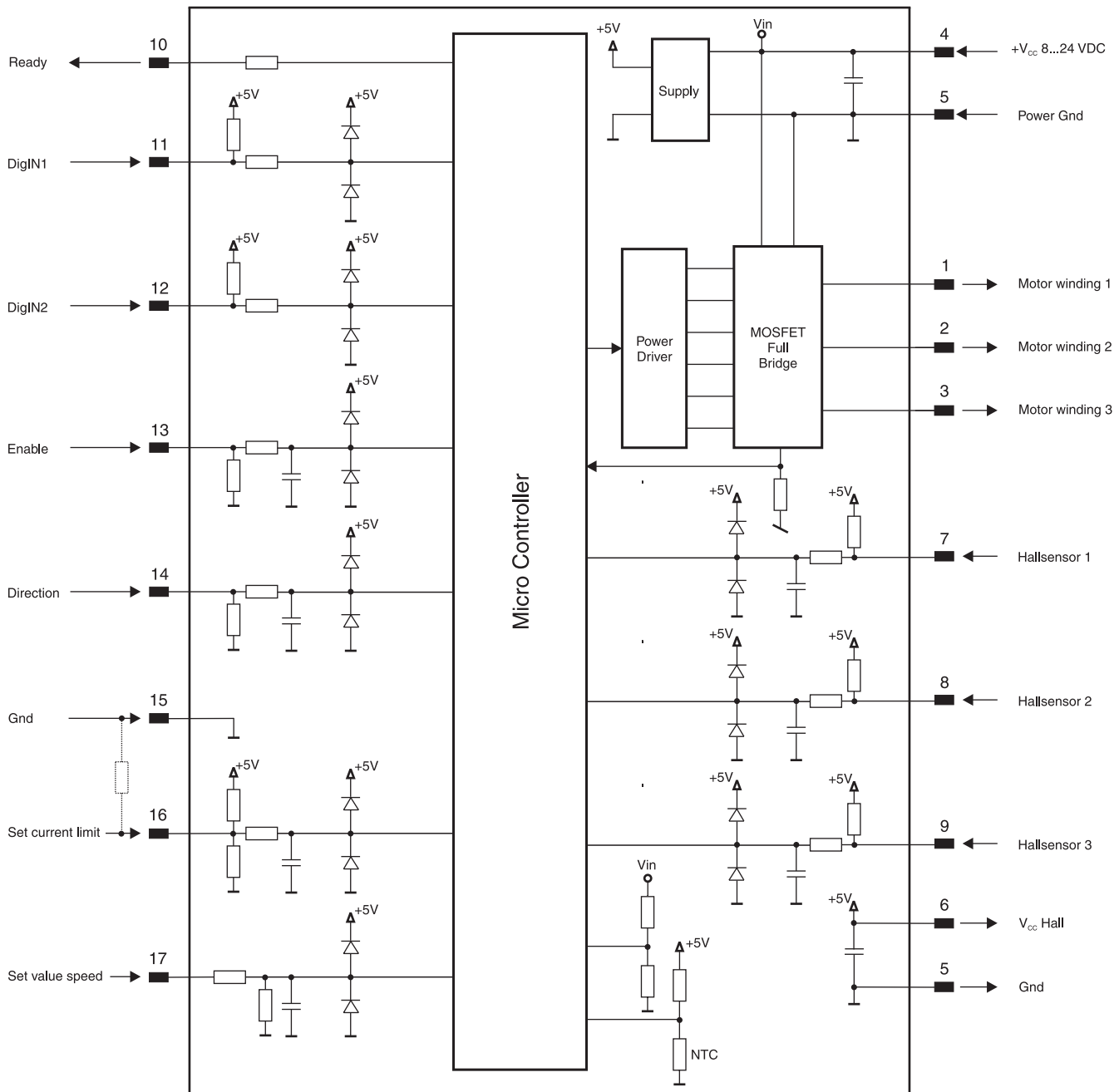

8 Dimensional Drawing

Dimensions in [mm]

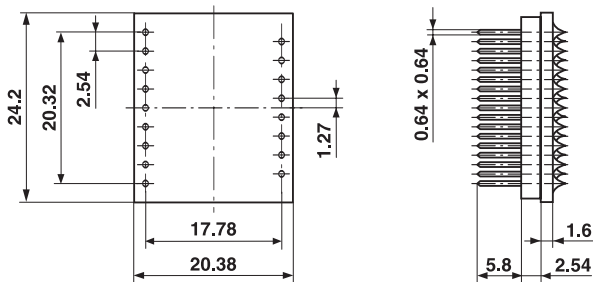

9 Accessories (not included in delivery)

maxon motor order number	Designation
370652	DEC Module Evaluation Board

10 Appendix «Motherboard Design Guide»

10.1 Introduction

The present documentation «Motherboard Design Guide» contains helpful information on the integration of the DEC Modules 24/2 into printed circuit boards. Contained therein are recommendations for possibly needed 3rd party components, suggestions on layout, terminal assignment as well as circuit samples.

Warning:

Development of printed circuits boards requires specific qualification and should only be performed by experienced electronics engineers. The present brief instruction is intended to serve as supporting aid only and does not claim completeness. Upon request, maxon motor ag is glad to assist and to offer customer-specific motherboard designs.

10.2 External components

10.2.1 Pin socket

The connector arrays used in the DEC Module 24/2 permits two possible types of connections. The module can either be mounted on socket terminal strips or soldered directly into the printed circuit board.

Pin socket recommendations:

Specifications:

- Pin socket vertical, single row, mates with pin header 0.63 x 0.63 mm, pitch 2.54 mm, 2 A, contact material gold or brass

Pin socket 8 poles:

- Preci-Dip 801-87-008-10-001101
- Samtec SSW-108-01-F-S
- Harwin M20-7820846

Pin socket 9 poles

- Preci-Dip 801-87-009-10-001101
- Samtec SSW-109-01-F-S
- Harwin M20-7820946

10.2.2 Supply voltage

To protect the DEC module from damage an external fuse, a TVS-diode and a capacitor in the power supply voltage line are recommended.

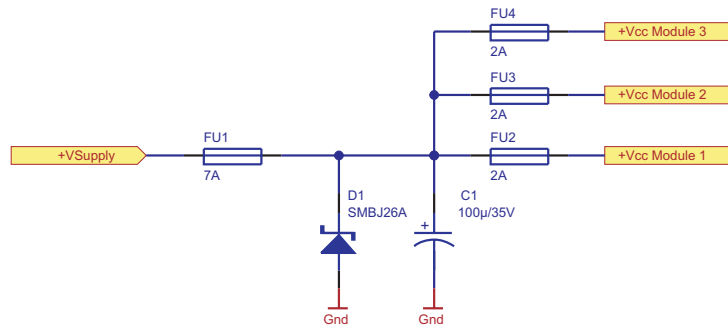

Fuse FU1:

To protect against reverse polarity, place a fuse at the entry of the power supply. Together with the TVS-diode, the fuse breaks an occurring reverse current. The continuous current of the fuse depends on the number of the DEC modules supplied and how much current each module needs.

Recommendations for the fuse:

- Littlefuse 154 Series OMNI-BLOK® fuse holder with SMD NANO²® Fuse installed:
 - 15402.5 for one module, 2.5 A very fast-acting
 - 154005. for two modules, 5 A very fast-acting
 - 154007. for four modules, 7 A very fast-acting

TVS-Diode D1:

To protect against overvoltage due to supply transients or the braking energy, connect a transient voltage suppressor diode to the power supply voltage.

Recommendations for the TVS-diode:

- Vishay SMBJ26A
 $U_R = 26 \text{ V}$, $U_{BR} = 28.9 \dots 32.1 \text{ V @ 1mA}$, $U_C = 42 \text{ V @ 14.3 A}$
- Diotec P6SMBJ26A
 $U_R = 26 \text{ V}$, $U_{BR} = 28.9 \dots 32.1 \text{ V @ 1mA}$, $U_C = 42 \text{ V @ 14.3 A}$

Capacitor C1:

An external capacitor is not mandatory for the function of the DEC module.

To reduce the voltage ripple in addition a ceramic capacitor can be connect to the power supply voltage.

The capacity needed depends on the following points:

- Power supply voltage
- Number of DEC modules

Recommendations for the capacitor (supplying one DEC module):

- Murata GRM32ER71H475KA88
 $C = 4.7 \mu\text{F}$, X7R, 50 V, 1210
- Kemet C1210C475K5RAC
 $C = 4.7 \mu\text{F}$, X7R, 50 V, 1210

Fuse FU2:

For protection against short circuit of the motor winding connections, it is recommended to place additionally one fuse per module. The fuse must stand 2 A continuously and 3 A during approx. 100 seconds with a typical melt I^2T smaller than 0.05 A²s.

Recommendations for the fuse:

- Bussmann 3216FF-2A, 3216FF Series, Fast acting, 2 A
- Wickmann FCD081200, SMD 0805 Series, Quick acting, 2 A

10.2.3 Motor phase

The DEC Module 24/2 has no built-in choke per phase.

For the most motors and applications no additional motor chokes are necessary. In case of high power supply voltage $+V_{CC}$ and a motor with very low inductance the current ripple will become too high, additional chokes on the motherboard are needed. The minimum inductance of each choke can be calculated with the formula below.

$$L_{Phase} \geq \frac{1}{2} \cdot \left(\frac{V_{CC}}{6 \cdot f_{PWM} \cdot I_N} - 0.3 \cdot L_{Motor} \right)$$

L_{Phase} [H]	External inductance per phase
V_{CC} [V]	Power supply voltage $+V_{CC}$
f_{PWM} [Hz]	PWM frequency = 46 800 Hz
I_N [A]	Nominal motor current (correspond to line 6 in maxon catalogue)
L_{Motor} [H]	Terminal inductance phase to phase of the motor

If the result of the formula is negative, no additional chokes are needed.

The chokes must have an electromagnetic shield, high saturation current, low losses and a rated current higher than the continuous motor current.

Recommendation for the motor choke:

- Coiltronics DR1040-220-R
 $L_N = 22 \mu\text{H}$, $R_{DC} = 54 \text{ m}\Omega$, $I_{DC} = 2.5 \text{ A}$, $I_{sat} = 2.9 \text{ A}$, shielded
- Bourns SRU1038-220Y
 $L_N = 22 \mu\text{H}$, $R_{DC} = 54 \text{ m}\Omega$, $I_{DC} = 2.2 \text{ A}$, $I_{sat} = 2.3 \text{ A}$, shielded
- Würth Elektronik WE-TPC-XLH 744066220
 $L_N = 22 \mu\text{H}$, $R_{DC} = 60 \text{ m}\Omega$, $I_{DC} = 2.5 \text{ A}$, $I_{sat} = 2.2 \text{ A}$, shielded

10.3 Design rules

To help customers designing an application specific motherboard and for correct and save function of the DEC Module 24/2 these rules can be followed.

10.3.1 Ground

The ground (Gnd) pins of the DEC Module are internally connected (same electrical potential). It is common practice to place a ground plane on the motherboard and it is necessary to connect pins [5] and [15] with thick tracks to the power supply voltage ground

Pin	Signals	Description
5	Gnd	Ground
15	Gnd	Ground

If ground safety earth is available, connect the ground plane over some parallel capacitors to the ground safety earth. Capacitors with 47 nF and 100 V are suggested.

10.3.2 Layout

Motherboard layouts for DEC Module 24/2 should follow these rules:

- Pin [4] +V_{CC}: Use thick track to connect to the fuse.
- Pins [5] and [15]: Use thick tracks to connect to supply voltage's ground (Gnd).
- The width and copper plating thickness of the power supply voltage and motor winding traces depend on the maximum current expected in the application. A minimum of 50 mil width at 35 μm thickness are recommended.

10.4 THT footprint

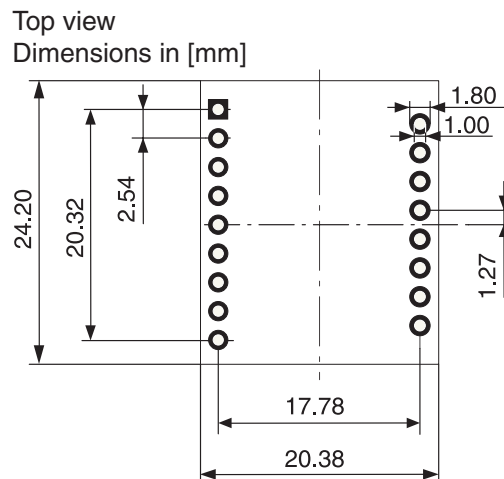

10.5 Pin description

See chapter [«3 Pin assignment DEC Module 24/2»](#)

10.6 Performance data

See chapter [«2 Performance data»](#)

10.7 Dimensional drawing

See chapter [«8 Dimensional drawing»](#)

10.8 Schematic examples

10.8.1 Minimum external wiring

Power supply (8...24 VDC); EC motor with Hall sensors; External set value speed potentiometer (10 k Ω); Enable switch
 Configuration: Speed controller (closed loop); Speed range 500...20 000 rpm.

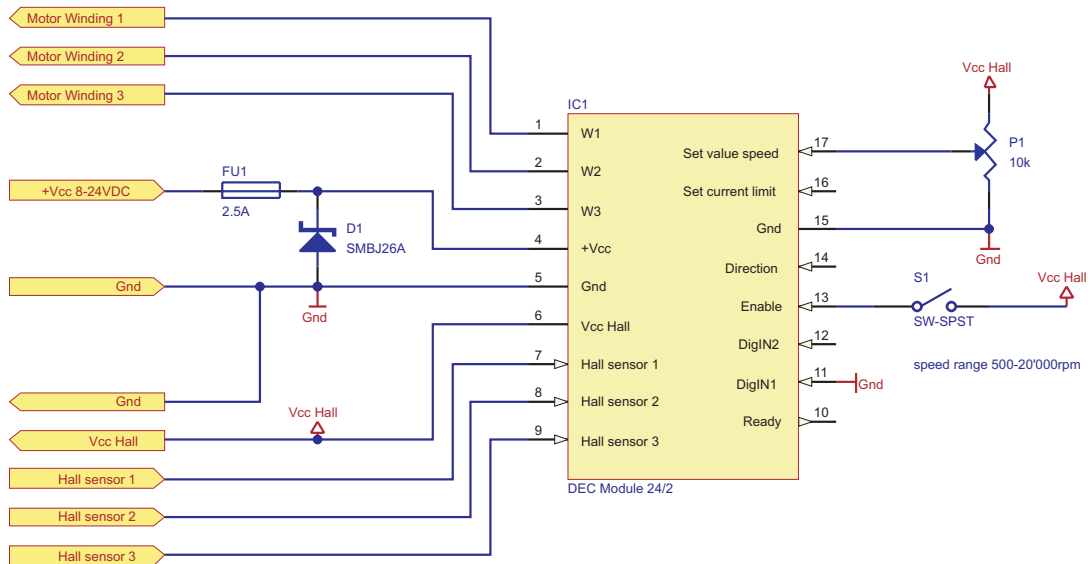

10.8.2 Low Voltage +5V operation

Alternatively, the DEC Module 24/2 can be operated with a supply voltage of +5 VDC ($\pm 5\%$). Thereby, the external +5 VDC power source must be connected to pin [4] «+V_{CC}» and, in addition, also to pin [6] «V_{CC} Hall».

Warning

The supply voltage must be between +4.5 VDC and +5.5 VDC. Voltages above +6.0 VDC or swapping poles will destroy the unit.

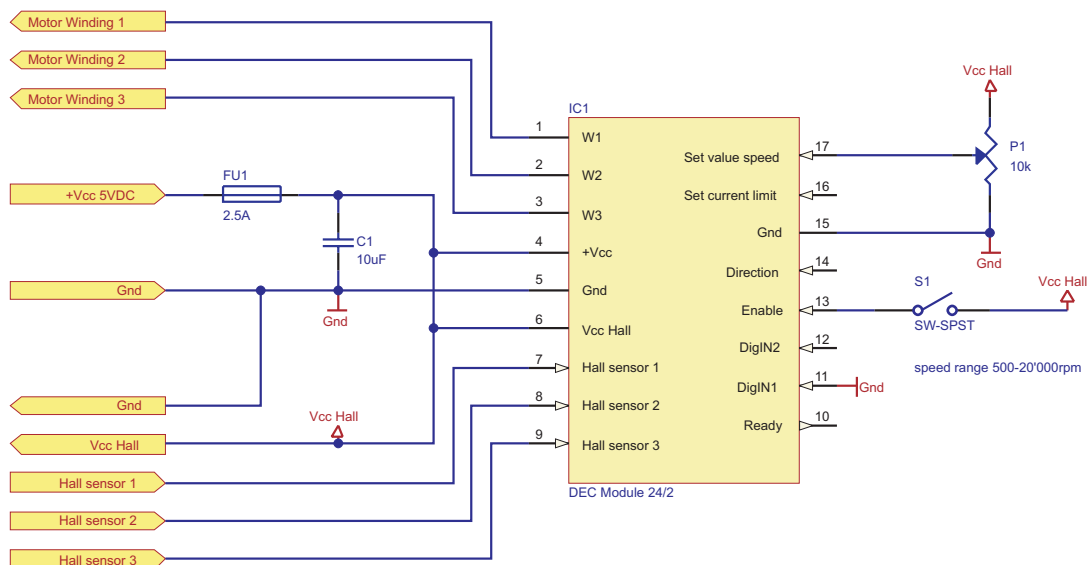

10.8.3 Maximum external wiring according to the DEC Module Evaluation Board order number 370652

For initial commissioning, maxon motor offers an Evaluation Board for a single-axis system. The motherboard «DEC Module Evaluation Board» can be ordered with order number 370652.

Evaluation Board schematic:

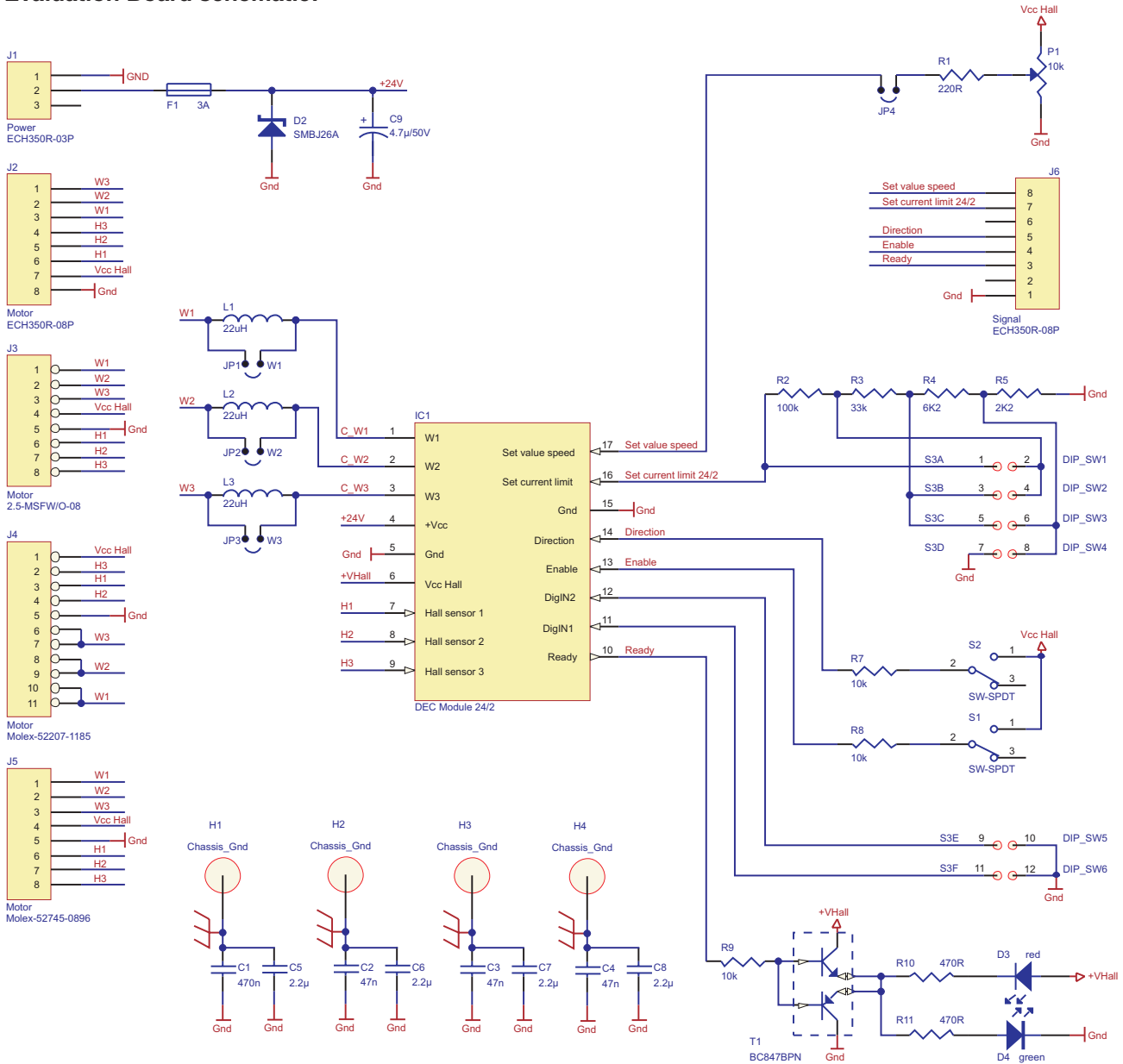

Set current limit 24/2 (examples)

	DIP-SW 1	DIP-SW 2	DIP-SW 3	DIP-SW 4
0.5A	ON	ON	ON	ON
1A	ON	ON	ON	OFF
1.5A	ON	OFF	OFF	ON
2A	ON	ON	OFF	OFF
2.5A	ON	OFF	ON	ON
3A	OFF	OFF	OFF	OFF

DIP-SW 5	DIP-SW 6	Speedrange		
DigIN2	DigIN1	1 pole pair	4 pole pairs	8 pole pairs
ON	ON	Open loop speed control, 0...100% PWM		
ON	OFF	500...5'000 rpm	125...1'250 rpm	62...625 rpm
OFF	ON	500...20'000 rpm	125...5'000 rpm	62...2'500 rpm
OFF	OFF	500...80'000 rpm	125...20'000 rpm	62...10'000 rpm

Picture of Evaluation Board with DEC Module 24/2:

