



Automotive

Freescale Wireless Charging Reference Design for Automotive Applications

Designed with automotive in mind

Overview

The 5WTXAUTO reference design is Freescale's wireless charging solution specifically designed for automotive applications. From component selection to system operating behavior, every design decision keeps the complex automotive environment in mind. The result is a highly optimized automotive system solution with a cost-competitive bill of materials (BOM) and maximum performance.

The design is based on the Wireless Power Consortium (WPC) A13 transmitter definition, comprising a 12 VDC source voltage, full H-bridge topology and rail voltage control method. The system is able to operate from an input source of 6–14 VDC, ideal for an automotive environment where the source voltage can dramatically vary. For example, many vehicles feature a Start/Stop function, turning the vehicle's engine off during periods of extended idle. When the vehicle starts back up, the battery voltage can droop excessively while the starter cranks the engine, creating low operating voltages for small periods of time. The rail voltage control method is ideal for reducing harmonics emissions, thereby addressing the necessary EMC requirements for industry. Freescale extends support beyond the specified A13 coil type to allow designers to choose the coil topology that best meets their needs.

This reference design uses Freescale's innovative wireless charging transmit controller to perform digital demodulation on incoming communication from the receiver, thereby reducing the need

Target Applications

- 5 W automotive applications

WCT-5WTXAUTO Multi-Coil Wireless Charger Block Diagram

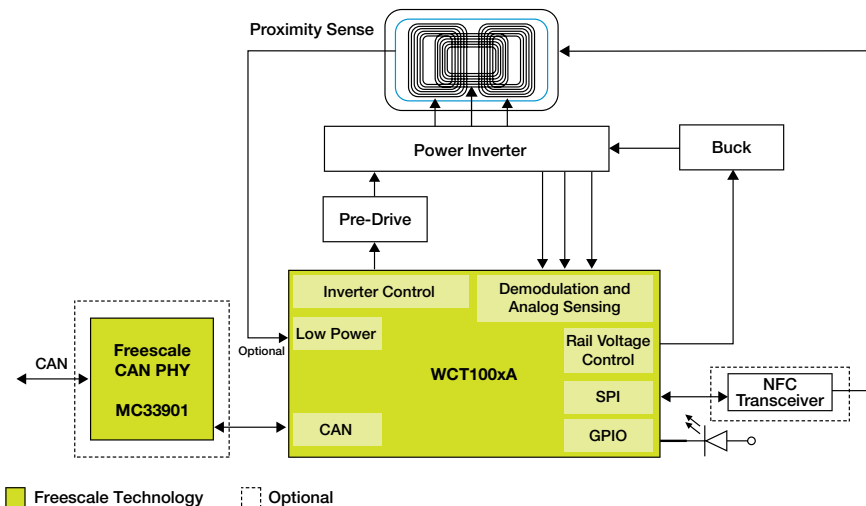

for external demodulation circuitry. Using the wireless charging transmit controller platform, with its unique DSP capabilities, allows demodulation to be performed in software with minimal CPU overhead. This unique feature provides a major reduction in BOM costs and the added benefit of a reduced PCB footprint without compromising system communications quality.

The transmitter reference design implements a robust foreign object detection scheme critical for the safe operation of the charger. Metallic objects are detected by calculating the power lost in the system, determining that a certain power loss threshold is deemed to be due to a metallic object. For WPC-Qi transmitters, this is a requirement in the specification.

The reference design showcases the portfolio's additional capabilities using Freescale MWCT1003A wireless charging IC implementing near field communications (NFC) functionality. Freescale's joint partnership with Melexis Semiconductor demonstrates the coexistence between wireless charging and NFC systems. On Freescale's platform, the wireless charging system provides a bridge between the NFC physical interface and the vehicle network. By co-locating both the wireless charging and NFC function, control can remain localized and a higher level of system integration can be obtained. This reduces overall system costs while maintaining implementation flexibility.

Additional features include the ability to enable CAN, utilizing Freescale's MC33901 CAN physical interface controller. As an alternative, LIN communication can also be established using the wireless charging transmitter's SCI interface. Lastly, the solution features an alternate low-power standby mode by utilizing proximity sensing. The hardware contains sensing electrodes which detect when the user places the mobile device on the charger. The proximity sensing algorithm uses the wireless charging

Features

Features	Benefits
Compliant to latest WPC Qi specification	Ensure end solution meets latest industry specification
Transfer efficiency greater than 60%	Maximum energy transfer and lower thermal footprint
Meets latest FOD requirements	Ensures foreign objects are detected and provides safety function
Supports many Qi 5 W coil types	Provides a broad range of magnetics support with a single solution
Low active RUN power	Increase overall operating efficiency
Low system standby power consumption (using Freescale proximity sense technology)	Lowest standby operating mode
Rail voltage power control	Reduce EMC to meet industry requirements
SPI, UART, I ² C communication interfaces	Communicate to and from wireless charging IC to transfer charging information (premium only)
On-chip digital demodulation	Lower system BOM and greater performance
Run-time calibration	Fast and accurate system calibration, saving time & effort to optimize system performance
Integrated CAN/LIN support	Connect to the vehicle network for control and management
Meets AEC-Q100 (Grade 2) guidelines	Meets latest automotive requirements
WCT firmware library	Choose as-is firmware or build value-added features onto existing library
NFC capable	Supports low-level NFC stack (MWCT1003A only)

Package Options

Part Number	Package	Available Flash Size	Key Features
MWCT1001A	64 LQFP	30 KB*	Complete controller solution, support most Qi 5W single coils
MWCT1003A	64 LQFP	220 KB*	Premium controller, I ² C, UART, SPI, flash memory for application programming

* Available memory is an estimate only

transmitter's GPIOs to detect a device and wake up the system.

Ultimately, the WCT-5WTXAUTO reference design is a complete system solution, containing all of the hardware and software components necessary to quickly implement a multicoil charger solution. Freescale provides all necessary hardware documentation, including schematics, layout and assembly files as well as a complete BOM. A firmware library is provided which contains all of the necessary wireless charging control blocks. Access to the library is provided via an API which lets users interact with parameters and settings contained in the firmware, providing maximum control to the engineer. Customers can choose to use a ready-to-use binary file provided by Freescale or to take a more developmental approach and build an application around the firmware library.

Development Tools

WCT-5WTXAUTO

Optimized multicoil 5 W reference design for automotive applications.

Eclipse™-based CodeWarrior Development Studio for Microcontrollers

A complete integrated development environment (IDE) that provides a highly visual and automated framework to accelerate the development of the most complex embedded applications.

WCTGUI

Graphical user interface tool for quickly configuring and optimizing wireless charging transmitter solutions.

For more information, visit freescale.com/WCT-5WTXAUTO

Freescale, the Freescale logo and CodeWarrior are trademarks of Freescale Semiconductor, Inc., Reg. U.S. Pat. & Trm. Off. All other product or service names are the property of their respective owners. © 2014 Freescale Semiconductor, Inc.

Document Number: WCT5WTXAUTOFS REV 1

