

SK-PICADILLO-35T (Starter Kit)



This item includes the following: Picadillo-35T Display Module, 5VDC International AC Adaptor, 2GB microSD Card and Quick Start User Guide



4D SYSTEMS

TURNING TECHNOLOGY INTO ART

Picadillo-35T

3.5" PIC32 Embedded Display Module

Compatible with the chipKIT™/Arduino™

DATASHEET

Document Date: 19th September 2014

Document Revision: 1.5

Contents

1. Description	4
2. Features	4
3. Pin Configuration and Summary	5
3.1. Header Pinout Summary – By Header and Pin Number	5
3.2. Jumper Pinout Summary	9
3.3. Header Pinout Summary – By IDE Pin Number	12
3.4. Header Pinout Summary – By PIC32 Chip Pin Number	15
4. Powering the Picadillo-35T	18
4.1. USB Power	18
4.2. DC Barrel Jack	18
4.3. Powering from the Headers	18
4.4. The Power Supplies	18
5. Programming the Picadillo-35T	19
5.1. Programming with UECIDE.....	19
5.2. Programming with Microchip Dev Tools	19
6. GPIO on the Picadillo-35T	20
6.1. GPIO Voltage Levels	20
6.2. Serial Ports	20
6.3. SPI.....	21
6.4. I2C	21
6.5. PWM.....	21
6.6. External Interrupts	22
6.7. Analog Reference	22
6.8. Analog Inputs	22
7. Additional Features	23
7.1. On Board Audio Amplifier	23
7.2. Real Time Clock Calendar	23
7.3. Touch Screen Interface	23
7.4. PIC32 on-board USB Controller	23
8. Display Features	23
8.1. Display – 3.5” TFT Touch Screen	23
8.2. Display Precautions	24
9. Software & Libraries	24
9.1. UECIDE Programming IDE	24
9.2. Libraries.....	24

9.3. Bootloader 25

10. Notes 26

11. Scribble Box..... 26

12. Mechanical Details..... 27

13. Schematic Diagram 28

14. Specifications and Ratings 29

15. Revisions 30

16. Legal Notice 31

17. Contact Information..... 31

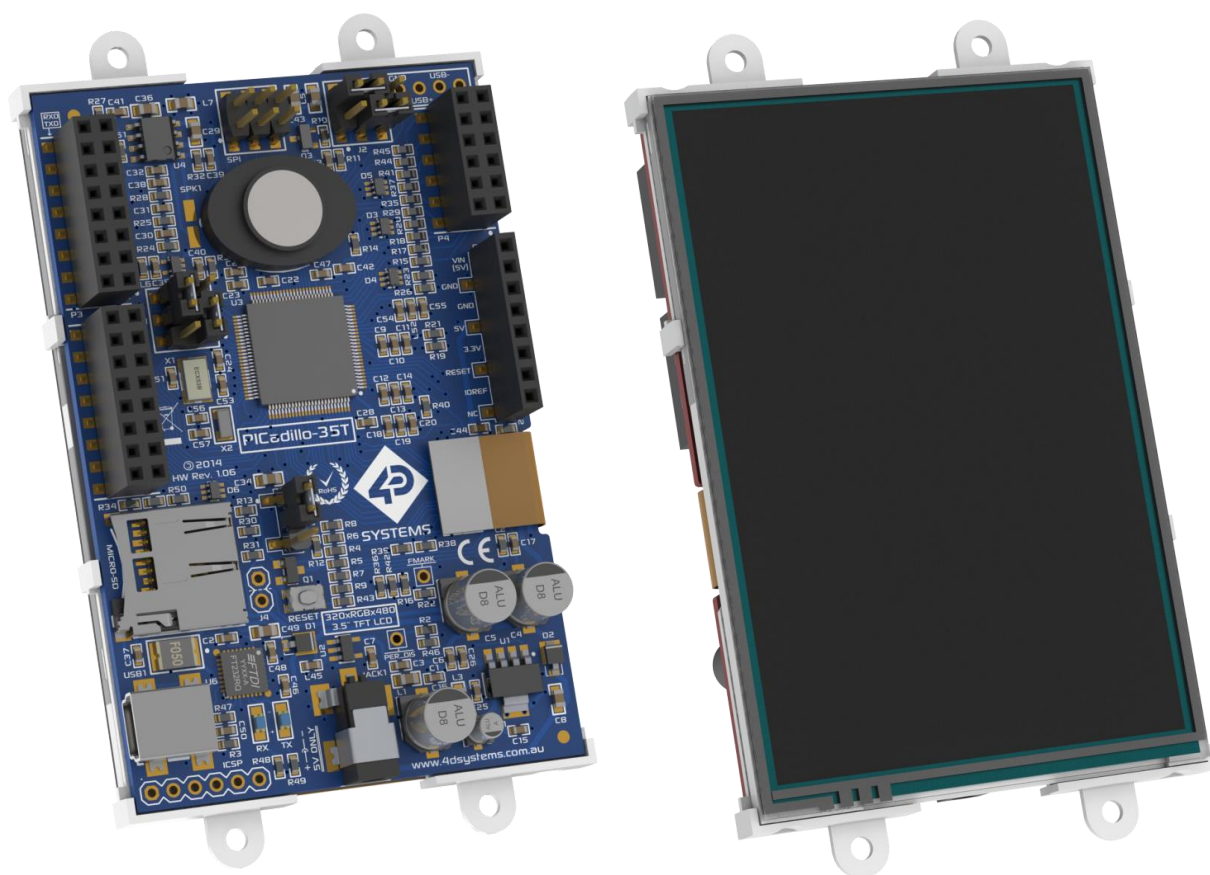

1. Description

The Picadillo-35T is a 3.5" 320x480 resolution (Half VGA) Embedded Display Module with Resistive Touch, featuring the Microchip PIC32MX795F512L 32bit microcontroller, featuring Arduino™/chipKIT™ style headers for easy attachment of shields, and compatible with UECIDE, MPIDE and MPLAB X Programming IDE's.

The Picadillo-35T was designed with complete system control in mind. It features a 3.5" display along with a ton of GPIO, making it a perfect candidate for system control which demands a GUI or user interface.

The PIC32MX795F512L is a powerful 32bit microcontroller from Microchip, which has 512Kb of Flash and 128Kb of SRAM, runs at 80Mhz and is capable of 105 DMIPS. It features a PMP graphics port which is used to connect the on board 3.5" display, allowing for fast graphics fully controlled by the Users code. The same PIC32 is found on the popular chipKIT Max32 Development Board.

The Picadillo-35T has been designed to be programmed using the UECIDE IDE, which is based on the Arduino IDE however with various enhancements and improvements. It can also be used with MPIDE, or even using Microchip MPLAB X. Using UECIDE or MPIDE, the display module can essentially be treated as if it was a chipKIT MAX32 and programmed using the familiar programming language found on the Arduino/chipKIT.

The Picadillo-35T features an on board FTDI USB to TTL converter for programming and powering the display, along with an ICSP connection for using programmers such as the PICKIT3.

Also featured on board is amicroSD connector, audio amplifier and speaker, RTC oscillator, and headers in the layout of the chipKit Uno32.

4D Systems highly recommends the UECIDE Programming IDE, which is available for download from www.uecide.org, which features the Picadillo-35T as a board for selection from the plugin system.

NOTE: Arduino, chipKIT and their TM's remains the property of the Arduino Team and Digilent inc respectively. All references to the words Arduino, chipKIT, Uno32, Max32 and their respective hardware are licensed under the Creative Commons Attribution Share-Alike license.

2. Features

- Powerful 3.5" Embedded LCD-TFT display module powered by a Microchip PIC32MX795F512L 32bit microcontroller.
- 320x480 HVGA Resolution, RGB 65K true to life colours, TFT Screen with integrated 4-wire Resistive Touch Panel.
- 512 Kbytes of Flash memory for User Application Code and Data.
- 128 Kbytes of SRAM.
- 47 General Purpose I/O pins for user interfacing, which include 13 Analog Inputs.
- Analog Inputs are 0V – 3.3V DC
- chipKIT Uno32 style headers, compatible with Arduino style shields, for easy interfacing.
- The GPIO is variously configurable for alternative functions such as:
 - Up to 4 I²C channels available
 - Up to 3 SPI channels available, with an additional channel dedicated for the microSD card.
 - Up to 4 TTL Serial Comm ports available
 - Up to 4 GPIO for PWM, can also be used for Audio and Backlight control
- On-board FTDI USB to TTL converter for power/programming.
- Breakout of the PIC32 on-board USB connections.
- On-board micro-SD memory card connector for multimedia storage and data logging purposes.
- Mono PWM Audio selectable using 1 of the PWM channels, filtered and fed to an on-board 1W amplifier, driving an on board speaker.
- 5.0V Supply, available to be powered from the on-board USB port, or 5V DC Jack. Compatible international 1Amp DC Adaptors are available.
- Module dimensions: 56.9 x 97.6 x 15.8mm (including corner plates). Weighing ~50 g.
- Display Viewing Area: 49.7 x 77.0mm
- 4x corner plates with 2.6mm holes for mechanical mounting.
- RoHS and CE Compliant.

3. Pin Configuration and Summary

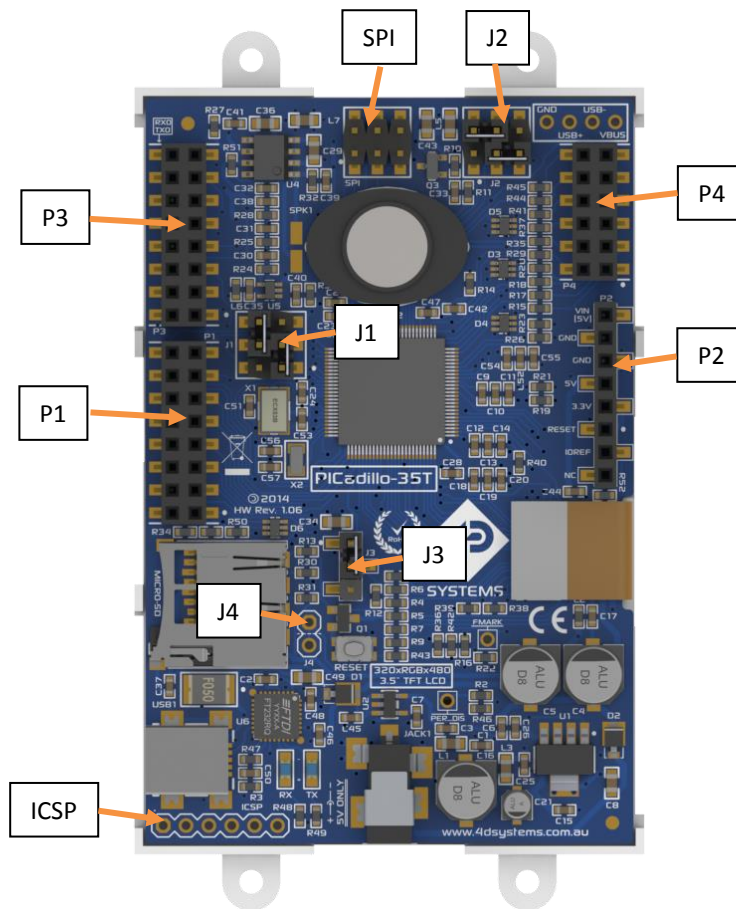

3.1. Header Pinout Summary – By Header and Pin Number

P2 Pinout (Centre Right)			
Pin	Symbol	I/O	Description
1	N/C		Not Connected
2	IOREF	P	3.3V Reference pin, used for Shields which utilise an IOREF capable module.
3	RESET	I	Master Reset signal. Internally pulled up to 3.3V via a 10K resistor. An active Low pulse greater than 2 micro-seconds will reset the module. If the module needs to be reset externally, use open collector type circuits or at least a 200R resistor to GND. This pin is not driven low by any internal conditions.
4	+3.3V	OP	+3.3V OUTPUT pin, which is connected to the LP38692MP-3.3 regulator, and capable of supplying up to 1Amp. Note this 3.3V supply is also used for the Display and microSD card.
5	+5V	OP	+5V OUTPUT pin. This pin is designed to power external devices such as Shields, not to power this module as it comes after the reverse polarity protection. Output will be approximately 4.7V with a 5.0V input on VIN.
6	GND	P	Supply Ground
7	GND	P	Supply Ground
8	VIN	IP	Main Supply INPUT, 5V DC ONLY . This pin is designed to power the display module, features reverse polarity protection. Input should not exceed 5.5V DC, else damage to the Amplifier, Display and FTDI chip could result.

Continued overleaf...

I = Input, O = Output, P = Power, IP = Input Power, OP = Output Power

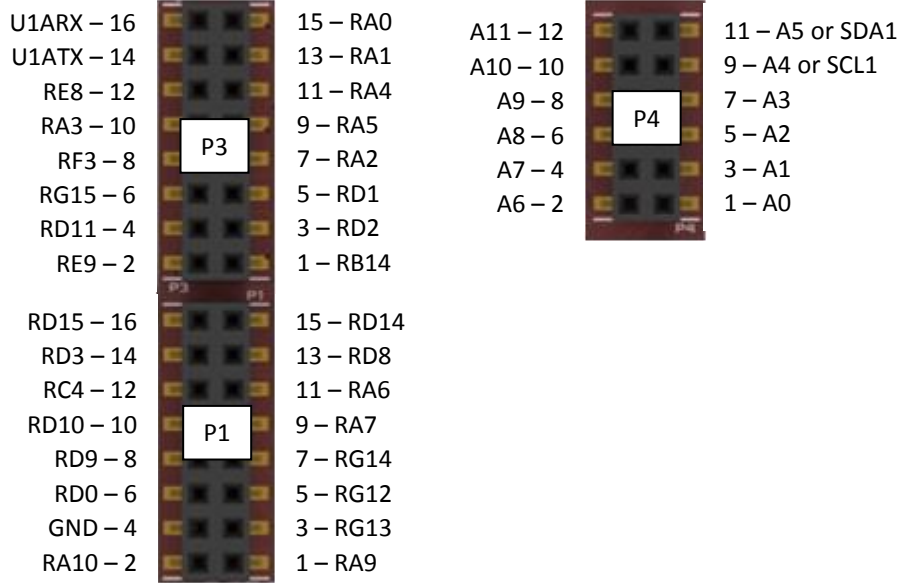

P4 Pinout (Top Right)					
Pin	Symbol	IDE Pin	Chip Pin	I/O	Description
1	AN0	A0 / 14	25	A/I/O	General Purpose I/O. This pin is 5.0V tolerant. PGED1/AN0/CN2/RB0
2	AN6	A6 / 20	26	A/I/O	General Purpose I/O. This pin is 5.0V tolerant. PGEC2/AN6/OCFA/RB6
3	AN1	A1 / 15	24	A/I/O	General Purpose I/O. This pin is 5.0V tolerant. PGEC1/AN1/CN3/RB1
4	AN7	A7 / 21	27	A/I/O	General Purpose I/O. This pin is 5.0V tolerant. PGED2/AN7/RB7
5	AN2	A2 / 16	23	A/I/O	General Purpose I/O. This pin is 5.0V tolerant. AN2/C2IN-/CN4/RB2
6	AN8	A8 / 22	32	A/I/O	General Purpose I/O. This pin is 5.0V tolerant. AN8/C1OUT/RB8
7	AN3	A3 / 17	22	A/I/O	General Purpose I/O. This pin is 5.0V tolerant. AN3/C2IN+/CN5/RB3
8	AN9	A9 / 23	33	A/I/O	General Purpose I/O. This pin is 5.0V tolerant. AN9/C2OUT/RB9
9	AN4/SCL1	A4 / 18	21/66	A/I/O	General Purpose I/O. This pin is 5.0V tolerant. AN4/C1IN-/CN6/RB4 or AETXCLK/SCL1/INT3/RA14
10	AN10	A10 / 24	34	A/I/O	General Purpose I/O. This pin is 5.0V tolerant. AN10/CVREFOUT/PMA13/RB10
11	AN5/SDA1	A5 / 19	20/67	A/I/O	General Purpose I/O. This pin is 5.0V tolerant. AN5/C1IN+/VBUSON/CN7/RB5 or AETXEN/SDA1/INT4/RA15
12	AN11	A11 / 25	35	A/I/O	General Purpose I/O. This pin is 5.0V tolerant. AN11/EREXERR/AETXERR/PMA12/RB11

Continued overleaf...

I = Input, O = Output, P = Power, A = Analog Input

P1 Pinout (Centre Left)					
Pin	Symbol	IDE Pin	Chip Pin	I/O	Description
1	RA9	41	28	I/O	General Purpose I/O. This pin is 5.0V tolerant. VREF-/CVREF-/AERXD2/PMA7/RA9
2	RA10	42	29	I/O	General Purpose I/O. This pin is 5.0V tolerant. VREF+/CVREF+/AERXD3/PMA6/RA10
3	RG13	40	97	I/O	General Purpose I/O. This pin is 5.0V tolerant. TRD0/RG13
4	GND	-	-	P	Supply Ground
5	RG12	39	96	I/O	General Purpose I/O. This pin is 5.0V tolerant. TRD1/RG12
6	RD0	13	72	I/O	General Purpose I/O. This pin is 5.0V tolerant. This pin is PWM Capable. SDO1/OC1/INT0/RD0
7	RG14	38	95	I/O	General Purpose I/O. This pin is 5.0V tolerant. TRD2/RG14
8	RD9	12	69	I/O	General Purpose I/O. This pin is 5.0V tolerant. SS1/IC2/RD9
9	RA7	37	92	I/O	General Purpose I/O. This pin is 5.0V tolerant. TRD3/RA7
10	RD10	11	70	I/O	General Purpose I/O. This pin is 5.0V tolerant. SCK1/IC3/PMCS2/PMA15/RD10
11	RA6	36	91	I/O	General Purpose I/O. This pin is 5.0V tolerant. RA6/TRCLK
12	RC4	10	9	I/O	General Purpose I/O. This pin is 5.0V tolerant. T5CK/SDI1/RC4
13	RD8	35	68	I/O	General Purpose I/O. This pin is 5.0V tolerant. RTCC/EMDIO/AEMDIO/IC1/RD8
14	RD3	9	78	I/O	General Purpose I/O. This pin is 5.0V tolerant. This pin is PWM Capable. OC4/RD3
15	RD14	34	47	I/O	General Purpose I/O. This pin is 5.0V tolerant. Requires Jumper J1 to be connected between Pin1 and Pin3. AETXD0/SS3/U4RX/U1CTS/CN20/RD14
16	RD15	8	48	I/O	General Purpose I/O. This pin is 5.0V tolerant. AETXD1/SCK3/U4TX/U1RTS/CN21/RD15

I = Input, O = Output, P = Power, A = Analog Input

P3 Pinout (Top Left)					
Pin	Symbol	IDE Pin	Chip Pin	I/O	Description
1	RB14	33	43	I/O/A	General Purpose I/O. This pin is capable of being an Analog Input, and therefore is only 3.3V logic. AN14/ERXD2/AETXD3/PMALH/PMA1/RB14
2	RE9	7	19	I/O	General Purpose I/O. This pin is 5.0V tolerant. AERXD1/INT2/RE9
3	RD2	32	77	I/O	General Purpose I/O. This pin is 5.0V tolerant. This pin is PWM Capable. OC3/RD2
4	RD11	6	71	I/O	General Purpose I/O. This pin is 5.0V tolerant. EMDC/AEMDC/IC4/PMCS1/PMA14/RD11
5	RD1	31	76	I/O	General Purpose I/O. This pin is 5.0V tolerant. This pin is PWM Capable. Requires Jumper J1 to be

					connected between Pin3 and Pin6. OC2/RD1
6	RG15	5	1	I/O	General Purpose I/O. This pin is 5.0V tolerant. AERXERR/RG15
7	RA2	30	58	I/O	General Purpose I/O. This pin is 5.0V tolerant. SCL2/RA2
8	RF3	4	51	I/O	General Purpose I/O. This pin is 5.0V tolerant. USBID/RF3
9	RA5	29	61	I/O	General Purpose I/O. This pin is 5.0V tolerant. TDO/RA5
10	RA3	3	59	I/O	General Purpose I/O. This pin is 5.0V tolerant. SDA2/RA3
11	RA4	28	60	I/O	General Purpose I/O. This pin is 5.0V tolerant. TDI/RA4
12	RE8	2	18	I/O	General Purpose I/O. This pin is 5.0V tolerant. AERXD0/INT1/RE8
13	RA1	27	29	I/O	General Purpose I/O. This pin is 5.0V tolerant. VREF+/CVREF+/AERXD3/PMA6/RA10
14	U1ATX	1	53	I/O	General Purpose I/O. This pin is 5.0V tolerant. Primary Serial Port, Serial0 Transmit SCL3/SDO3/U1TX/RF8
15	RA0	26	17	I/O	General Purpose I/O. This pin is 5.0V tolerant. TMS/RA0
16	U1ARX	0	52	I/O	General Purpose I/O. This pin is 5.0V tolerant. Primary Serial Port, Serial0 Receive SDA3/SDI3/U1RX/RF2

I = Input, O = Output, P = Power, A = Analog Input

SPI Header Pinout (Top Centre)					
Pin	Symbol	IDE Pin	Chip Pin	I/O	Description
1	SDI4	49	49	I/O	SDA5/SDI4/U2RX/PMA9/CN17/RF4
2	N/C	-	-	-	Not Connected
3	SCK4	50	39	I/O	AC1TX/SCK4/U5TX/U2RTS/RF13
4	SDO4	51	50	I/O	SCL5/SDO4/U2TX/PMA8/CN18/RF5
5	SS4	52	40	I/O	AC1RX/SS4/U5RX/U2CTS/RF12
6	GND	-	-	P	Supply Ground

I = Input, O = Output, P = Power, A = Analog Input



3.2. Jumper Pinout Summary

J1 Jumper Pinout (Central Left)				
Pin	Symbol	Chip Pin	I/O	Description
1	RB14	43	I/O	When the Jumper is placed between Pin1 and Pin3, RB14 will be made available on P3 Pin 1
2	RD1	76	I/O	When the Jumper is placed between Pin2 and Pin4, RD1 will be made available on P3 Pin 5
3	-	-	-	Connected to P3 Pin 1. Either RB14 or AUDENB, depending on Jumper.
4	-	-	-	Connected to P3 Pin 5. Either RD1 or AUDIO, depending on Jumper.
5	AUDENB	-	I/O	When the Jumper is placed between Pin5 and Pin3, RD14 is not available on P3 Pin 1, and is instead used to enable/disable the on-board Audio Amplifier
6	AUDIO	-	P	When the Jumper is placed between Pin6 and Pin4, RD1 is not available on P3 Pin 5, and is instead used to generate Audio which is then filtered and fed into the on-board amplifier.

I = Input, O = Output, P = Power, A = Analog Input

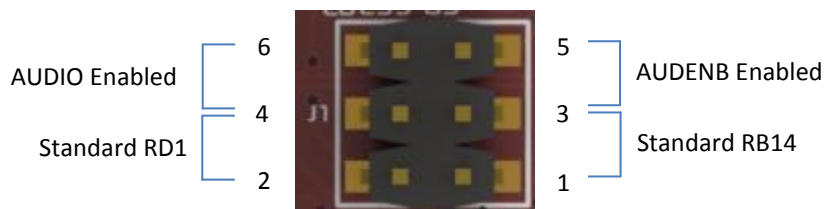

J2 Jumper Pinout (Top Right)				
Pin	Symbol	Chip Pin	I/O	Description
1	SCL1	66	I/O	When the Jumper is placed between Pin1 and Pin3, SCL1 will be made available on P4 Pin 9
2	SDA1	67	I/O	When the Jumper is placed between Pin2 and Pin4, SDA1 will be made available on P4 Pin 11
3	-	-	-	Connected to P4 Pin 9. Either SCL1 or AN4 depending on Jumper
4	-	-	-	Connected to P4 Pin 11. Either SDA1 or AN5 depending on Jumper.
5	AN4	21	I/O	When the Jumper is placed between Pin5 and Pin3, AN4 will be made available on P4 Pin 9
6	AN5	20	I/O	When the Jumper is placed between Pin6 and Pin4, AN5 will be made available on P4 Pin 11

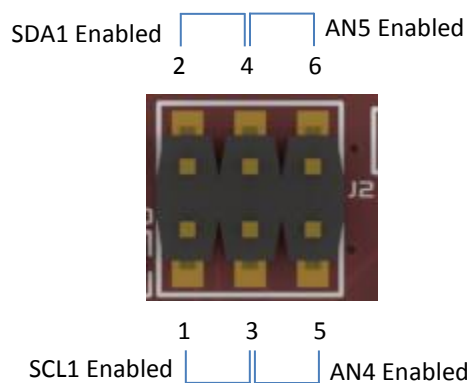

J3 Jumper Pinout (Central)				
Pin	Symbol	Chip Pin	I/O	Description
1	+3.3V	-	P	When the Jumper is placed between Pin1 and Pin2, the backlight will be forced on 100%, and not controllable by software
2	BACKLITE	-	-	This pin is connected to the backlight circuitry
3	RD2	77	I/O	When the Jumper is placed between Pin2 and Pin3, the backlight will be connected to RD2 which is PWM capable, so the backlight can be dimmed with software. RD2 is still connected to P3 Pin 3, so be weary of this.

I = Input, O = Output, P = Power, A = Analog Input

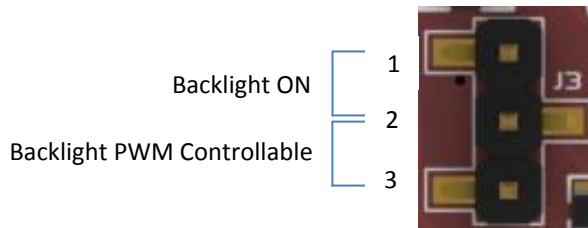

J4 Jumper Pinout (Central)		
Pin	Symbol	Description
1	RESET	Both of these pads are connected to RESET. In the rare case that the Auto-Reset function is not required, which is where RESET is pulled low from the DTR signal of the FTDI USB to UART converter chip when programming takes place, the small track between the 2 pads of this header can be cut. If this function is wanted to be restored, a header could be carefully soldered in place, or a jumper wire placed between the pads to enable Auto-Reset once again. Please note, this is an unpopulated header.
2	RESET	As above.



ICSP Header Pinout (Bottom Left)				
Pin	Symbol	Chip Pin	I/O	Description
1	RESET	-	-	Master Reset signal. Internally pulled up to 3.3V via a 10K resistor. An active Low pulse greater than 2 micro-seconds will reset the module. This pin is not driven low by any internal conditions.
2	N/C	-	-	Not Connected
3	GND	-	P	Power Ground
4	PGED2	27	I/O	Data I/O pin for Programming/ Debugging Communication Channel 2
5	PGEC2	26	I	Clock input pin for Programming/ Debugging Communication Channel 2
6	N/C	-	-	Not Connected

I = Input, O = Output, P = Power, A = Analog Input

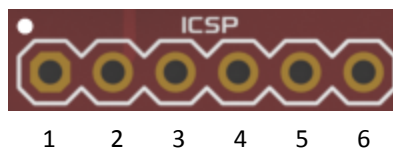

3.3. Header Pinout Summary – By IDE Pin Number

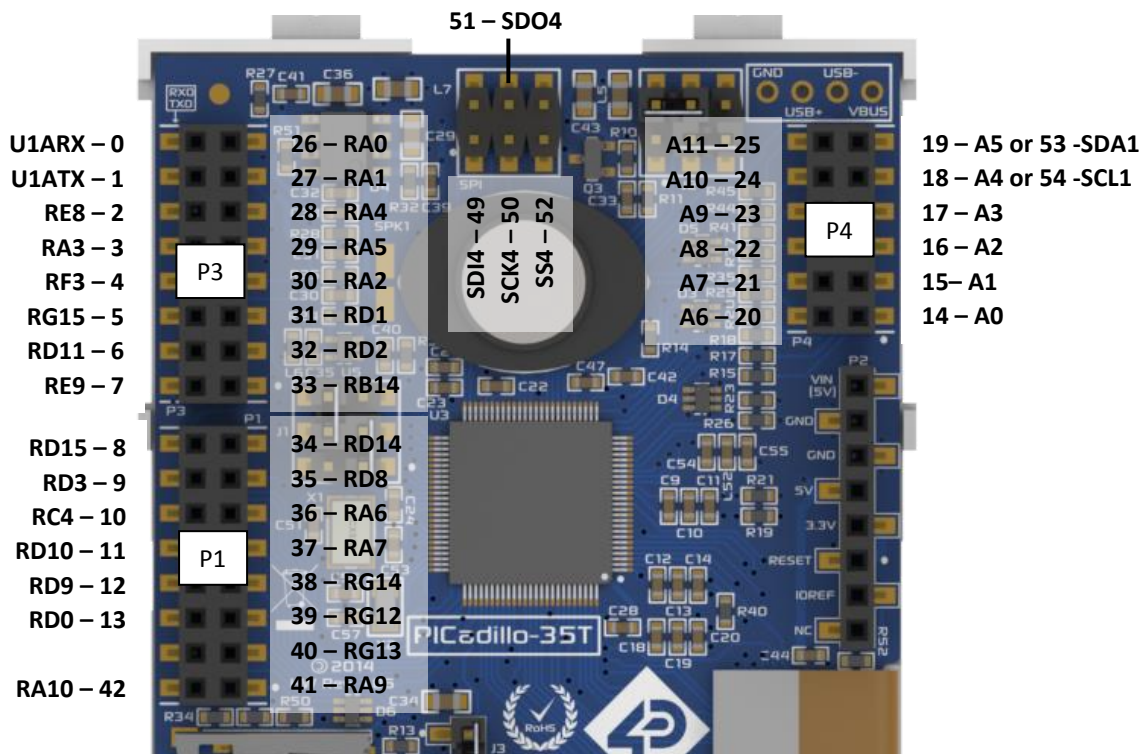

IDE Pin	Symbol	Chip Pin	I/O	Description
0	U1ARX	52	I/O	General Purpose I/O. This pin is 5.0V tolerant. Primary Serial Port, Serial0 Receive SDA3/SDI3/U1RX/RF2
1	U1ATX	53	I/O	General Purpose I/O. This pin is 5.0V tolerant. Primary Serial Port, Serial0 Transmit SCL3/SDO3/U1TX/RF8
2	RE8	18	I/O	General Purpose I/O. This pin is 5.0V tolerant. AERXD0/INT1/RE8
3	RA3	59	I/O	General Purpose I/O. This pin is 5.0V tolerant. SDA2/RA3
4	RF3	51	I/O	General Purpose I/O. This pin is 5.0V tolerant. USBID/RF3
5	RG15	1	I/O	General Purpose I/O. This pin is 5.0V tolerant. AERXERR/RG15
6	RD11	71	I/O	General Purpose I/O. This pin is 5.0V tolerant. EMDC/AEMDC/IC4/PMCS1/PMA14/RD11
7	RE9	19	I/O	General Purpose I/O. This pin is 5.0V tolerant. AERXD1/INT2/RE9
8	RD15	48	I/O	General Purpose I/O. This pin is 5.0V tolerant. AETXD1/SCK3/U4TX/U1RTS/CN21/RD15
9	RD3	78	I/O	General Purpose I/O. This pin is 5.0V tolerant. This pin is PWM Capable. OC4/RD3
10	RC4	9	I/O	General Purpose I/O. This pin is 5.0V tolerant. T5CK/SDI1/RC4
11	RD10	70	I/O	General Purpose I/O. This pin is 5.0V tolerant. SCK1/IC3/PMCS2/PMA15/RD10

IDE Pin	Symbol	Chip Pin	I/O	Description
12	RD9	69	I/O	General Purpose I/O. This pin is 5.0V tolerant. SS1/IC2/RD9
13	RD0	72	I/O	General Purpose I/O. This pin is 5.0V tolerant. This pin is PWM Capable. SDO1/OC1/INT0/RD0
14 (A0)	AN0	25	A/I/O	General Purpose I/O. This pin is 5.0V tolerant. PGED1/AN0/CN2/RB0
15 (A1)	AN1	24	A/I/O	General Purpose I/O. This pin is 5.0V tolerant. PGEC1/AN1/CN3/RB1
16 (A2)	AN2	23	A/I/O	General Purpose I/O. This pin is 5.0V tolerant. AN2/C2IN-/CN4/RB2
17 (A3)	AN3	22	A/I/O	General Purpose I/O. This pin is 5.0V tolerant. AN3/C2IN+/CN5/RB3
18 (A4)	AN4	21	A/I/O	General Purpose I/O. This pin is 5.0V tolerant. AN4/C1IN-/CN6/RB4
19 (A5)	AN5	20	A/I/O	General Purpose I/O. This pin is 5.0V tolerant. AN5/C1IN+/VBUSON/CN7/RB5
20 (A6)	AN6	26	A/I/O	General Purpose I/O. This pin is 5.0V tolerant. PGEC2/AN6/OCFA/RB6
21 (A7)	AN7	27	A/I/O	General Purpose I/O. This pin is 5.0V tolerant. PGED2/AN7/RB7
22 (A8)	AN8	32	A/I/O	General Purpose I/O. This pin is 5.0V tolerant. AN8/C1OUT/RB8
23 (A9)	AN9	33	A/I/O	General Purpose I/O. This pin is 5.0V tolerant. AN9/C2OUT/RB9
24 (A10)	AN10	34	A/I/O	General Purpose I/O. This pin is 5.0V tolerant. AN10/CVREFOUT/PMA13/RB10
25 (A11)	AN11	35	A/I/O	General Purpose I/O. This pin is 5.0V tolerant. AN11/EREXERR/AETXERR/PMA12/RB11
26	RA0	17	I/O	General Purpose I/O. This pin is 5.0V tolerant. TMS/RA0
27	RA1	38	I/O	General Purpose I/O. This pin is 5.0V tolerant. TCK/RA1
28	RA4	60	I/O	General Purpose I/O. This pin is 5.0V tolerant. TDI/RA4
29	RA5	61	I/O	General Purpose I/O. This pin is 5.0V tolerant. TDO/RA5
30	RA2	58	I/O	General Purpose I/O. This pin is 5.0V tolerant. SCL2/RA2
31	RD1	76	I/O	General Purpose I/O. This pin is 5.0V tolerant. This pin is PWM Capable. Requires Jumper J1 to be connected between Pin3 and Pin6. OC2/RD1
32	RD2	77	I/O	General Purpose I/O. This pin is 5.0V tolerant. This pin is PWM Capable. OC3/RD2
33 (A14)	RB14	43	I/O/A	General Purpose I/O. This pin is capable of being an Analog Input, and therefore is only 3.3V logic. AN14/ERXD2/AETXD3/PMALH/PMA1/RB14
34	RD14	47	I/O	General Purpose I/O. This pin is 5.0V tolerant. Requires Jumper J1 to be connected between Pin1 and Pin3. AETXD0/SS3/U4RX/U1CTS/CN20/RD14
35	RD8	68	I/O	General Purpose I/O. This pin is 5.0V tolerant. RTCC/EMDIO/AEMDIO/IC1/RD8

IDE Pin	Symbol	Chip Pin	I/O	Description
36	RA6	91	I/O	General Purpose I/O. This pin is 5.0V tolerant. RA6/TRCLK
37	RA7	92	I/O	General Purpose I/O. This pin is 5.0V tolerant. TRD3/RA7
38	RG14	95	I/O	General Purpose I/O. This pin is 5.0V tolerant. TRD2/RG14
39	RG12	96	I/O	General Purpose I/O. This pin is 5.0V tolerant. TRD1/RG12
40	RG13	97	I/O	General Purpose I/O. This pin is 5.0V tolerant. TRD0/RG13
41	RA9	28	I/O	General Purpose I/O. This pin is 5.0V tolerant. VREF-/CVREF-/AERXD2/PMA7/RA9
42	RA10	29	I/O	General Purpose I/O. This pin is 5.0V tolerant. VREF+/CVREF+/AERXD3/PMA6/RA10
43	RB12	41	-	YU (Y Up) – <u>Used exclusively for Touch Screen</u>
44	RB13	42	-	XL (X Left) – <u>Used exclusively for Touch Screen</u>
45	RC2	7	-	YD (Y Down) – <u>Used exclusively for Touch Screen</u>
46	RC3	8	-	XR (X Right) – <u>Used exclusively for Touch Screen</u>
47	RC1	6	O	LCD Display Reset – <u>Used exclusively for Display</u>
48	RG9	14	O	SD Card CS/SS – <u>Used exclusively for SD Card</u> ERXCLK/AERXCLK/EREFCLK/AEREFCLK/SS2/U6RX/ U3CTS/PMA2/CN11/RG9
49	RF4	49	I/O	General Purpose I/O. SPI Header MISO. SDA5/SDI4/U2RX/PMA9/CN17/RF4
50	RF13	39	I/O	General Purpose I/O. SPI Header SCK. SCK4/U5TX/U2RTS/RF13
51	RF5	50	I/O	General Purpose I/O. SPI Header MOSI. SCL5/SDO4/U2TX/PMA8/CN18/RF5
52	RF12	40	I/O	General Purpose I/O. SPI Header CS/SS. SS4/U5RX/U2CTS/RF12
53	RA15	67	I/O	General Purpose I/O. I2C SDA. AETXEN/SDA1/INT4/RA15
54	RA14	66	I/O	General Purpose I/O. I2C SCL AETXCLK/SCL1/INT3/RA14
55	RG7	11	O	SD Card MOSI – <u>Used exclusively for SD Card.</u> ECRS/SDA4/SDI2/U3RX/PMA4/CN9/RG7
56	RG8	12	I	SD Card MISO – <u>Used exclusively for SD Card.</u> ERXDV/AERXDV/ECRSDV/AECRSDV/SCL4/SDO2/U3TX/PMA3/ CN10/RG8
57	RG6	10	O	SD Card SCK – <u>Used exclusively for SD Card.</u> ECOL/SCK2/U6TX/U3RTS/PMA5/CN8/RG6

3.4. Header Pinout Summary – By PIC32 Chip Pin Number

Chip Pin	IDE Pin	Symbol	I/O	Description
1	5	RG15	I/O	General Purpose I/O. This pin is 5.0V tolerant. AERXERR/RG15
2				VDD
3				PMD5 – <u>Used for the Display</u>
4				PMD6 – <u>Used for the Display</u>
5				PMD7 – <u>Used for the Display</u>
6	47	RC1	O	LCD Display Reset – <u>Used exclusively for Display</u>
7	45	RC2	-	YD (Y Down) – <u>Used exclusively for Touch Screen</u>
8	46	RC3	-	XR (X Right) – <u>Used exclusively for Touch Screen</u>
9	10	RC4	I/O	General Purpose I/O. This pin is 5.0V tolerant. T5CK/SDI1/RC4
10	57	RG6	O	SD Card SCK – <u>Used exclusively for SD Card.</u> ECOL/SCK2/U6TX/U3RTS/PMA5/CN8/RG6
11	55	RG7	O	SD Card MOSI – <u>Used exclusively for SD Card.</u> ECSR/SDA4/SDI2/U3RX/PMA4/CN9/RG7
12	56	RG8	I	SD Card MISO – <u>Used exclusively for SD Card.</u> ERXDV/AERXDV/ECRSDV/AECRSDV/SCL4/SDO2/U3TX/PMA3/ CN10/RG8
13				MCLR
14	48	RG9	O	SD Card CS/SS – <u>Used exclusively for SD Card</u> ERXCLK/AERXCLK/EREFCLK/AEREFCLK/SS2/U6RX/ U3CTS/PMA2/CN11/RG9
15				VSS
16				VDD
17	26	RA0	I/O	General Purpose I/O. This pin is 5.0V tolerant. TMS/RA0
18	2	RE8	I/O	General Purpose I/O. This pin is 5.0V tolerant. AERXD0/INT1/RE8
19	7	RE9	I/O	General Purpose I/O. This pin is 5.0V tolerant. AERXD1/INT2/RE9
20	19 (A5)	AN5	A/I/O	General Purpose I/O. This pin is 5.0V tolerant. AN5/C1IN+/VBUSON/CN7/RB5
21	18 (A4)	AN4	A/I/O	General Purpose I/O. This pin is 5.0V tolerant. AN4/C1IN-/CN6/RB4
22	17 (A3)	AN3	A/I/O	General Purpose I/O. This pin is 5.0V tolerant. AN3/C2IN+/CN5/RB3
23	16 (A2)	AN2	A/I/O	General Purpose I/O. This pin is 5.0V tolerant. AN2/C2IN-/CN4/RB2
24	15 (A1)	AN1	A/I/O	General Purpose I/O. This pin is 5.0V tolerant. PGEC1/AN1/CN3/RB1
25	14 (A0)	AN0	A/I/O	General Purpose I/O. This pin is 5.0V tolerant. PGED1/AN0/CN2/RB0
26	20 (A6)	AN6	A/I/O	General Purpose I/O. This pin is 5.0V tolerant. PGEC2/AN6/OCFA/RB6
27	21 (A7)	AN7	A/I/O	General Purpose I/O. This pin is 5.0V tolerant. PGED2/AN7/RB7
28	41	RA9	I/O	General Purpose I/O. This pin is 5.0V tolerant. VREF-/CVREF-/AERXD2/PMA7/RA9
29	42	RA10	I/O	General Purpose I/O. This pin is 5.0V tolerant. VREF+/CVREF+/AERXD3/PMA6/RA10
30				AVDD

31				AVSS
32	22 (A8)	AN8	A/I/O	General Purpose I/O. This pin is 5.0V tolerant. AN8/C1OUT/RB8
33	23 (A9)	AN9	A/I/O	General Purpose I/O. This pin is 5.0V tolerant. AN9/C2OUT/RB9
34	24 (A10)	AN10	A/I/O	General Purpose I/O. This pin is 5.0V tolerant. AN10/CVREFOUT/PMA13/RB10
35	25 (A11)	AN11	A/I/O	General Purpose I/O. This pin is 5.0V tolerant. AN11/EREXERR/AETXERR/PMA12/RB11
36				VSS
37				VDD
38	27	RA1	I/O	General Purpose I/O. This pin is 5.0V tolerant. TCK/RA1
39	50	RF13	I/O	General Purpose I/O. SPI Header SCK. SCK4/U5TX/U2RTS/RF13
40	52	RF12	I/O	General Purpose I/O. SPI Header CS/SS. SS4/U5RX/U2CTS/RF12
41	43	RB12	-	YU (Y Up) – <u>Used exclusively for Touch Screen</u>
42	44	RB13	-	XL (X Left) – <u>Used exclusively for Touch Screen</u>
43	33 (A14)	RB14	I/O/A	General Purpose I/O. This pin is capable of being an Analog Input, and therefore is only 3.3V logic. AN14/ERXD2/AETXD3/PMALH/PMA1/RB14
44				PMA0 – <u>Used for the Display</u>
45				VSS
46				VDD
47	34	RD14	I/O	General Purpose I/O. This pin is 5.0V tolerant. AETXD0/SS3/U4RX/U1CTS/CN20/RD14
48	8	RD15	I/O	General Purpose I/O. This pin is 5.0V tolerant. AETXD1/SCK3/U4TX/U1RTS/CN21/RD15
49	49	RF4	I/O	General Purpose I/O. SPI Header MISO. SDA5/SDI4/U2RX/PMA9/CN17/RF4
50	51	RF5	I/O	General Purpose I/O. SPI Header MOSI. SCL5/SDO4/U2TX/PMA8/CN18/RF5
51	4	RF3	I/O	General Purpose I/O. This pin is 5.0V tolerant. USBID/RF3
52	0	U1ARX	I/O	General Purpose I/O. This pin is 5.0V tolerant. Primary Serial Port, Serial0 Receive SDA3/SDI3/U1RX/RF2
53	1	U1ATX	I/O	General Purpose I/O. This pin is 5.0V tolerant. Primary Serial Port, Serial0 Transmit SCL3/SDO3/U1TX/RF8
54				VBUS
55				VUSB
56				D-/RG3 – Broken out to access USB Signals
57				D+/RG2 – Broken out to access USB Signals
58	30	RA2	I/O	General Purpose I/O. This pin is 5.0V tolerant. SCL2/RA2
59	3	RA3	I/O	General Purpose I/O. This pin is 5.0V tolerant. SDA2/RA3
60	28	RA4	I/O	General Purpose I/O. This pin is 5.0V tolerant. TDI/RA4
61	29	RA5	I/O	General Purpose I/O. This pin is 5.0V tolerant. TDO/RA5
62				VDD
63				OSC1/CLKI/RC12 – <u>Main Clock Crystal Oscillator</u>

64				<u>OSC2/CLKO/RC15 – Main Clock Crystal Oscillator</u>
65				VSS
66	54	RA14	I/O	General Purpose I/O. I2C SCL AETXCLK/SCL1/INT3/RA14
67	53	RA15	I/O	General Purpose I/O. I2C SDA. AETXEN/SDA1/INT4/RA15
68	35	RD8	I/O	General Purpose I/O. This pin is 5.0V tolerant. RTCC/EMDIO/AEMDIO/IC1/RD8
69	12	RD9	I/O	General Purpose I/O. This pin is 5.0V tolerant. SS1/IC2/RD9
70	11	RD10	I/O	General Purpose I/O. This pin is 5.0V tolerant. SCK1/IC3/PMCS2/PMA15/RD10
71	6	RD11	I/O	General Purpose I/O. This pin is 5.0V tolerant. EMDC/AEMDC/IC4/PMCS1/PMA14/RD11
72	13	RD0	I/O	General Purpose I/O. This pin is 5.0V tolerant. This pin is PWM Capable. SDO1/OC1/INT0/RD0
73				<u>SOSCI/CN1/RC13 – RTC Clock Crystal Oscillator</u>
74				<u>SOSCO/T1CK/CN0/RC14 – RTC Clock Crystal Oscillator</u>
75				VSS
76	31	RD1	I/O	General Purpose I/O. This pin is 5.0V tolerant. This pin is PWM Capable. OC2/RD1
77	32	RD2	I/O	General Purpose I/O. This pin is 5.0V tolerant. This pin is PWM Capable. OC3/RD2
78	9	RD3	I/O	General Purpose I/O. This pin is 5.0V tolerant. This pin is PWM Capable. OC4/RD3
79				<u>ETXD2/IC5/PMD12/RD12 – Used for the Display</u>
80				<u>ETXD3/PMD13/CN19/RD13 – Used for the Display</u>
81				<u>OC5/PMWR/CN13/RD4 – Used for the Display</u>
82				<u>PMRD/CN14/RD5 – Used for the Display</u>
83				<u>ETXEN/PMD14/CN15/RD6 – Used for the Display</u>
84				<u>ETXCLK/PMD15/CN16/RD7 – Used for the Display</u>
85				VCAP/VDDCORE
86				VDD
87				<u>ETXD1/PMD11/RF0 – Used for the Display</u>
88				<u>ETXD0/PMD10/RF1 – Used for the Display</u>
89				<u>ETXERR/PMD9/RG1 – Used for the Display</u>
90				<u>PMD8/RG0 – Used for the Display</u>
91	36	RA6	I/O	General Purpose I/O. This pin is 5.0V tolerant. RA6/TRCLK
92	37	RA7	I/O	General Purpose I/O. This pin is 5.0V tolerant. TRD3/RA7
93				<u>PMD0/RE0 – Used for the Display</u>
94				<u>PMD1/RE1 – Used for the Display</u>
95	38	RG14	I/O	General Purpose I/O. This pin is 5.0V tolerant. TRD2/RG14
96	39	RG12	I/O	General Purpose I/O. This pin is 5.0V tolerant. TRD1/RG12
97	40	RG13	I/O	General Purpose I/O. This pin is 5.0V tolerant. TRD0/RG13
98				<u>PMD2/RE2 – Used for the Display</u>
99				<u>PMD3/RE3 – Used for the Display</u>
100				<u>PMD4/RE4 – Used for the Display</u>

4. Powering the Picadillo-35T

4.1. USB Power

The Picadillo-35T is able to be powered numerous ways, however the most common will be using the USB Mini jack, which is also used to program the display module.

The Picadillo-35T runs off a 5.0V DC supply, and draws approximately 250mA using an average arrangement of features at any given time. This is within the suitable limits of supply for most computers USB ports, however in some cases a powered USB hub or external power supply may be required.

There is a 500mA PTC resettable fuse located on the 5V line coming from the USB, to protect the computer against excessive current draw which may damage your PC if any unfortunate events occur while developing with the Picadillo-35T.

4.2. DC Barrel Jack

The Picadillo-35T Features a DC Barrel Jack, designed for a fine pitch DC Jack, 2.35mm in diameter, with a centre hole of 0.7mm, and barrel length of 8mm or more.

A suitable 1 Amp 5.0V DC Adaptor is available from the 4D Systems website, which has been designed specifically for 4D Systems.

The Barrel Jack on board is a CUI Inc PJ1-023-SMT if more information is required.

4.3. Powering from the Headers

The Picadillo-35T is able to be powered off the Arduino style headers. There is a VIN pin located on Pin 8 of the P2 Header. This pin accepts only 5.0VDC, with a maximum input of approximately 5.5VDC. Input outside this range could damage the module as some peripherals run directly of the 5V bus.

There is also a +5V pin, located on Pin 5 of the P2 header. This is NOT designed for direct input, this is an output pin for supplying external devices. This pin comes after the reverse polarity protection, so it is designed for output only. This pin will supply approximately $V_{IN} - 0.3V$.

4.4. The Power Supplies

On board the Picadillo-35T are two 3.3V regulators. There are no 5.0V regulators, so power input to the Picadillo-35T is required to be a regulated 5.0V supply.

There is a dedicated LP2992IM5-3.3 3.3V 250mA regulator for the PIC32 itself, which aims to provide the PIC32 with an isolated supply so any noise induced by external circuits will be at a minimum relative to the PIC32's supply.

There is then a 3.3V Max 1A regulator for the peripherals and for the User, which is a LP38692MP-3.3. This powers peripherals such as the microSD card, and the display logic. The +3.3V pin on the P2 header, is powered off this supply. This supply is enabled by default, but there is a single pad on the PCB labelled PER_DIS, which can be grounded and this regulator will be disabled. This may be useful for low power solutions.

The Audio Amplifier is powered directly off the 5V bus, however its power supply is enabled/disabled using the RB14 GPIO, which needs to be selected using the J1 header.

The FTDI FT232RQ is powered off the 5V bus, however features a simple switching circuit which holds it in reset unless the USB cable is attached. If powering the Picadillo-35T off the Barrel Jack or 5V header, then the FT232RQ will remain disabled.

The LCD Backlight is also powered directly off the 5V bus, and therefore the backlight may be damaged if the display module is supplied with power outside the recommended ranges.

When powering the display, multiple power sources can be connected if desired, such as USB and Barrel Jack, or USB and 5V Header Input. There is a simple diode pair on board, so which ever has the highest voltage will take over supply to the display module. This protects multiple supplies from fighting each other, and allows the DC Barrel Jack to be used to power the display while programming it over the USB port.

5. Programming the Picadillo-35T

5.1. Programming with UECIDE

UECIDE is the perfect programming environment for programming the Picadillo-35T using a standard USB Mini cable.

UECIDE features the Picadillo-35T in its list of plug-ins which are available for download, so after a very simple setup, the IDE is ready to use with the Picadillo-35T. Please refer to the www.uecide.org website for further information.

The UECIDE communicates between the Computer and the PIC32 using the Serial Port via the FTDI FT232RQ chip, and uses a bootloader running on the PICadillo-35T.

Before any attempts are made to communicate with the Picadillo-35T, the appropriate FTDI Driver must be downloaded and installed in order to successfully establish communications. This driver is available for download from the product page of the Picadillo-35T on the 4D Systems website, www.4dsystems.com.au

When UECIDE needs to communicate with the Picadillo-35T, the PIC32 is reset and it starts running the bootloader. UECIDE then establishes communication with the PIC32 using the bootloader, and downloads the program to the Flash of the PIC32.

When UECIDE establishes communication with the Picadillo-35T, the DTR pin of the FT232RQ is driven low, initiating the reset sequence. This reset pin is coupled through a series capacitor to the MCLR pin on the PIC32 microcontroller.

The automatic reset feature is able to be disabled through the cutting of a trace on the PCB between the pads of the J4 jumper. J4 is not populated by default, but allows a header to be soldered carefully in place if the trace is cut and the auto reset feature is desired to be restored.

There are 2 LED's present on the board, which indicate RX and TX traffic through the FT232RQ.

The same information can be applied when using MPIDE, however UECIDE is the recommended IDE.

5.2. Programming with Microchip Dev Tools

In addition to being used with the UECIDE or MPIDE, the Picadillo-35T board can be used as a more traditional microcontroller development board using the Microchip Development Tools.

The unpopulated ICSP connector located at the bottom left of the PCB is used to connect to a Microchip development tool, such as the PICKit3™.

Any Microchip development tool that supports the PIC32 microcontroller family, and can be connected via the same 6-pin interface as the PICKit3, can be used.

Typically, a right-angle male connector is used in the ICSP header location so that a PICKit3 can be attached co-planar with the Picadillo-35T module. The connector must be loaded from the top and carefully soldered in place. The PICKit3 will be upright (button and LEDs visible), with Pin 1 located on the Left Hand Side, and marked with a dot.

Note, the ICSP header does not provide a 3.3V connection to the Picadillo-35T, as more than 3.3V is required to power up the module. The 3.3V pin is therefore N/C, and an external power supply must be used, such as power from the USB, DC Jack or 5V Header pin.

Note: On the PICKit3 Programmer, the 3.3V Output to 'Power Target Circuit from Tool' must be enabled else the programmer will not see the PIC32 processor, even though this 3.3V is not used to power the Picadillo-35T itself.

The Microchip MPLAB® IDE or the MPLAB® X IDE can be used to program and debug code running on the Picadillo-35T board. These programs can be downloaded from the Microchip web site.

Using the Microchip development tools to program the Picadillo-35T board will cause the bootloader to be erased. To use the board with the UECIDE or MPIDE again, it is necessary to program the bootloader back onto the board. The bootloader source code and compiled image can be found on the 4D Systems website, under the Picadillo-35T product page, www.4dsystems.com.au

6. GPIO on the Picadillo-35T

6.1. GPIO Voltage Levels

The Picadillo-35T features a Microchip PIC32 microcontroller, which itself runs off 3.3V. Typically the Arduino range of development boards was 5.0V and therefore shields used 5.0V IO. The concern with development platforms that run 3.3V logic is whether they can handle 5V input signals from external devices, and whether the 3.3V logic levels will be high enough to activate a logic high condition on 5V logic shields.

The Picadillo-35T feature a PIC32 which has 5V tolerant digital GPIO, which means that 5V logic can be safely connected to this modules digital GPIO without any worry of damage to the module.

The analog input pins however are only 3.3V, and therefore inputs on those pins (AN0 through AN11, along with RB12) should not have inputs exceeding 3.3V. That said, the Picadillo-35T features clamp diodes and current limiting resistors, which aims to protect the processor from over voltage conditions, such as 5V logic inputs. It is therefore safe to use 5V inputs on these pins, however it should be noted the analog inputs will only read up to a 3.3V level.

When using this board with 5V shields, it should be noted that the minimum high level voltage level of the PIC32 is 2.4V when sourcing 12mA of current. While some 5V shields/devices will accept this as a logic high level, some will not. Many 5V logic devices will however work correctly with 3.3V logic.

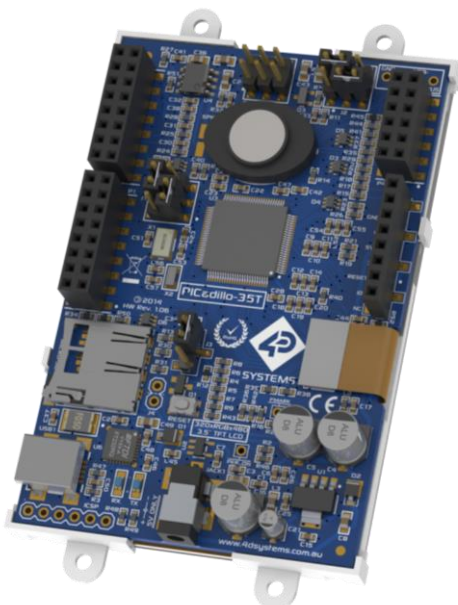

6.2. Serial Ports

The Picadillo-35T makes available 4 Serial UART ports of the PIC32 for the User.

UART port 0: Asynchronous serial port. RX0 and TX0. These pins are connected to the P3 Header and are also connected to the FT232R USB serial converter. It is possible to use these pins to connect to an external serial device when not using the USB serial interface. This uses UART1 on the PIC32 microcontroller itself.

Name	Chip Pin	IDE Pin	Header
U1RX (RX0)	52	0	P3 Pin16
U1TX (TX0)	53	1	P3 Pin14

UART port 1: Asynchronous serial port. RX1 and TX1. These pins are connected to the P1 Header. This uses UART4 on the PIC32 microcontroller itself, RD14 and RD15.

Name	Chip Pin	IDE Pin	Header
U4RX (RX1)	47	34	P1 Pin15
U4TX (TX1)	48	8	P1 Pin16

UART port 2: Asynchronous serial port. RX2 and TX2. These pins are connected to the SPI Header. This uses UART2 on the PIC32 microcontroller, RF4 and RF5.

Name	Chip Pin	IDE Pin	Header
U2RX (RX2)	49	49	SPI Pin1
U2TX (TX2)	50	51	SPI Pin4

UART port 3: Asynchronous serial port. RX3 and TX3. These pins are connected to the SPI Header. This uses UART5 on the PIC32 microcontroller, RF12 and RF13.

Name	Chip Pin	IDE Pin	Header
U5RX (RX3)	40	52	SPI Pin5
U5TX (TX3)	39	50	SPI Pin3

6.3. SPI

The Picadillo-35T features an on board microSD card connector, which communicates to the PIC32 via the SPI Bus. Please note that a microSD card which supports SPI is a requirement.

microSD Card: The on board microSD connector uses the SPI2 port which is (SS2, SDI2, SDO2, SCK2) on the PIC32 microcontroller, RG9, RG7, RG8, RG6. These are the IDE pins used for the microSD Card:

Name	Chip Pin	IDE Pin
SS2 (CS)	14	48
SDI2 (MOSI)	11	55
SDO2 (MISO)	12	56
SCK2 (SCK)	10	57

These signals are not broken out to any headers, and only feature on the microSD socket itself.

SPI Header, SPI Channel 1: Synchronous serial port.

The SPI Header, labelled 'SPI' and located at the top centre of the Picadillo-35T, uses the SPI4 port which is (SS4, SDI4, SDO4, SCK4) on the PIC32 microcontroller, RF12, RF5, RF4, RF13.

These are the IDE pins used for the SPI Header:

Name	Chip Pin	IDE Pin	Header
SS4 (CS)	40	52	SPI Pin5
SDI4 (MOSI)	49	49	SPI Pin1
SDO4 (MISO)	50	51	SPI Pin4
SCK4 (SCK)	39	50	SPI Pin3

SPI Channel 2: Synchronous serial port.

On the P1 Header, there is an SPI Port available which uses the SPI1 port which is (SS1, SDI1, SDO1, SCK1) on the PIC32 microcontroller, RD9, RC4, RD0, RD10.

These are the IDE pins used for this SPI channel.

Name	Chip Pin	IDE Pin	Header
SS1 (CS)	69	12	P1 Pin8
SDI1 (MOSI)	9	10	P1 Pin12
SDO1 (MISO)	72	13	P1 Pin6
SCK1 (SCK)	70	11	P1 Pin10

SPI Channel 3: Synchronous serial port.

There is an SPI Port available which uses the SPI3 port which is (SS3, SDI3, SDO3, SCK3) on the PIC32 microcontroller, RD14, RF2, RF8, RD15.

These are the IDE pins used for this SPI channel.

Name	Chip Pin	IDE Pin	Header
SS3 (CS)	47	34	P1 Pin15

SDI3 (MOSI)	52	0	P3 Pin16
SDO3 (MISO)	53	1	P3 Pin14
SCK3 (SCK)	48	8	P1 Pin16

6.4. I2C

I2C Channel 1: Synchronous serial port.

After selecting Jumper J2 to the appropriate location, I2C is available on the P4 header. This uses I2C1 on the PIC32 microcontroller, RA15 and RA14.

Name	Chip Pin	IDE Pin	Header
SDA1	67	53	P4 Pin11
SCL1	66	54	P4 Pin9

Note: The I2C channel on the Picadillo-35T does not feature on board I2C pull-up resistors, which are required as I2C uses open collector drivers. Typical pull-up resistors around 4K7 ohm are acceptable, however does depend on the number of devices found on the bus, the length of the wires, and the clock speed being used.

Note: Additional I2C channels are available. Please refer to the Microchip datasheet for more information on these ports, and then cross reference using the Schematic found in the appendix, to find the pin and header they are found on the Picadillo-35T.

6.5. PWM

There are 4 PWM channels available on the Picadillo-35T, and 2 of these have on board functions if the appropriate jumper is placed.

Name	Chip Pin	IDE Pin	Header
OC1 (RD0)	72	13	P1 Pin6
OC2 (RD1)	76	31	P3 Pin5
OC3 (RD2)	77	32	P3 Pin3
OC4 (RD3)	78	9	P1 Pin14

OC2/RD1 - this can be used to generate PWM audio which then feeds into the on board Audio Amplifier. Requires the J1 Jumper to be set correctly.

OC3/RD2 - this can be used to control the backlight with PWM to set various level of backlight brightness. Requires the J3 Jumper to be set correctly.

6.6. External Interrupts

There are 5 External Interrupts available on the Picadillo-35T. Please take note that some are located on pins used for other functions, so decisions need to be made as to which is utilised for your application.

Name	Chip Pin	IDE Pin	Header
INT0 (RD0)	72	13	P3 Pin10
INT1 (RE8)	18	2	P3 Pin12
INT2 (RE9)	19	7	P3 Pin2
INT3 (RA14)	66	54	P4 Pin9
INT4 (RA15)	67	53	P4 Pin11

INT3 – This is shared with the I2C Port, and can be used as a GPIO/INT with the appropriate selection of the J2 Jumper.

INT4 – This is shared with the I2C Port, and can be used as a GPIO/INT with the appropriate selection of the J2 Jumper

6.7. Analog Reference

It is possible to specify an Analog Reference to be something other than the internal 3.3V reference used by default, by applying a voltage to P1 Pin 2. The external voltage must be between 0V and 3.3V. If an external voltage is not required, this pin can be used as a GPIO digital pin.

There is a negative voltage reference also, found on P1 Pin 1, however this generally is unused as the default negative input is tied to AGND.

Please refer to the Microchip datasheet of the PIC32 for more information.

Name	Chip Pin	IDE Pin	Header
VREF+ (RA10)	29	42	P1 Pin2
VREF- (RA9)	28	41	P1 Pin1

Note: When these pins are used for Analog References, they cannot be used for GPIO.

6.8. Analog Inputs

The Picadillo-35T features 13 Analog Inputs which are accessible to the User. These are all by default in the range of 0V to 3.3VDC, however this can be altered with the use of the Analog Reference pins, discussed in the previous section.

Each of the Analog Inputs is 10-bit resolution, and capable up to a maximum of 1Msps read rate.

Each analog input is fitted with current limiting resistors and clamp diodes, to protect the inputs from overvoltage conditions, such as applying 5V to these inputs. If 5V is applied, the circuitry will clamp the voltage down to 3.3V. It is not possible to read an analog voltage with a level higher than 3.3V.

Of the 13 Analog Inputs, 12 of them are located on Header P4, which is the 'normal' location for Arduino/Chipkit style boards. There is an additional analog Input on the Picadillo-35T which is found on Header P3 Pin1 (AN14, aka RB14). This can be utilised as an Analog input if required, however is typically used to control the Audio Amplifier Enable.

Name	Chip Pin	IDE Pin	Header
AN0	25	A0 / 14	P4 Pin1
AN1	24	A1 / 15	P4 Pin3
AN2	23	A2 / 16	P4 Pin5
AN3	22	A3 / 17	P4 Pin7
AN4	21	A4 / 18	P4 Pin9
AN5	20	A5 / 19	P4 Pin11
AN6	26	A6 / 20	P4 Pin2
AN7	27	A7 / 21	P4 Pin4
AN8	32	A8 / 22	P4 Pin6
AN9	33	A9 / 23	P4 Pin8
AN10	34	A10 / 24	P4 Pin10
AN11	35	A11 / 25	P4 Pin12
AN14	43	A14 / 33	P3 Pin1

7. Additional Features

7.1. On Board Audio Amplifier

The Picadillo-35T features an on-board amplifier, capable of driving up to 1W and up to a 4ohm speaker, or the small speaker found on board the module itself.

The on-board amplifier is fed from the PIC32 using a filtered PWM signal, and also features an amplifier enable so the amplifier can be disabled by the user.

Based on the settings applied to Jumper J1, will determine if the PWM signal and Audio Enable signals are routed from the PIC32, or if they are routed to the headers for alternate use. It is not possible to have the audio and amplifier enabled if the 2 GPIO are desired to be used by the User for other uses.

Name	Chip Pin	IDE Pin
AUDIO (RD1)	47	31
AUDENB (RB14)	43	33

The AUDENB signal is Active Low, meaning you need to drive the AUDENB signal low in order to Enable the on board amplifier. Drive the pin high, or setting the pin to INPUT will disable the amplifier. The Amplifier Enable pin on the amplifier itself has a pull-up resistor, which will by default hold the amplifier to be in a disabled state.

The on-board amplifier is an ST TDA2822D.

If a larger external speaker is desired, instead of the small on board speaker, it can be carefully unsoldered from the + and – pads on the PCB, and a larger speaker be connected in its place. Please note the amplifier can drive a max of 4ohm load and a max of 1W (when using a 32ohm speaker). The recommended speaker rating is 8ohm 0.8W.

7.2. Real Time Clock Calendar

The Picadillo-35T utilises the built in RTCC found on the PIC32 that can be used to maintain time and date information. It has an on board 32.768KHz oscillator mounted and ready to go.

Please refer to the Microchip datasheet for this PIC32 processor, for more information about the RTCC.

7.3. Touch Screen Interface

The Picadillo-35T has a 4 wire touch screen interface. The following pins (2 Analog, 2 Digital) are used to interface to the 4 wire touch:

Name	Ref	Chip Pin	IDE Pin
YU (Y Up)	RB12	41	43
XL (X Left)	RB13	42	44
YD (Y Down)	RC2	7	45
XR (X Right)	RC3	8	46

Note: These pins are dedicated to the LCD displays 4 wire touch, and are not present on any other headers or pins.

7.4. PIC32 on-board USB Controller

The on-board USB 2.0 controller built into the PIC32, has been broken out to 4 pads at the top right of the Picadillo-35T. Wires or a header can be soldered carefully on to this location, allowing the User to take advantage of the on board USB port of the PIC32 Processor.

Note: This is not the same USB that is present down the bottom left of the Picadillo-35T.

For more information on this USB Port, please refer to the Datasheet for the PIC32 from the Microchip website.

8. Display Features

8.1. Display – 3.5" TFT Touch Screen

The Picadillo-35T module is equipped with a 3.5" TFT display. Details of the display are listed below:

- Screen Size: 3.5" diagonal, 320x480 resolution, 65K colours
- Integrated 4-Wire Resistive Touch Screen
- Screen Dimensions: 54.5 x 83.0 x 3.35mm
- Viewing Area: 49.76 x 77.04mm
- Pixel Pitch: 0.153(H) x 0.153(V)mm
- Brightness: 220cd/m²
- Contrast Ratio: 500:1
- Viewing Angle Above Centre: 60 degrees
- Viewing Angle Below Centre: 60 degrees
- Viewing Angle Left of Centre: 70 degrees
- Viewing Angle Right of Centre: 70 degrees
- Viewing Direction: 6 O'clock
- 7 LEDs for Backlighting

Note: The Displays used are the highest rated 'Grade A' Displays, which allow for 0-4 defective pixels. A defective pixel could be solid Black (Dead), White, Red, Green or Blue.

8.2. Display Precautions

- Avoid having to display the same image/object on the screen for lengthy periods of time. This will cause a burn-in which is a common problem with all types of display technologies. Blank the screen after a while or dim it very low by adjusting the contrast. Better still; implement a screen saver feature.
- Moisture and water can damage the display. Moisture on the surface of a powered display will cause the electrodes to corrode. Wipe off any moisture gently or let the display dry before usage.
- Dirt from fingerprint oil and fat can easily stain the surface of the display. Gently wipe off any stains with a soft lint-free cloth.
- The performance of the display will degrade under high temperature and humidity. Avoid such conditions when storing.
- Do not tamper with the display flex cable that is connected to the control board. This may affect the connection between the display and the driving circuitry and cause failure. Under **NO CIRCUMSTANCES** should you disconnect the FPC connector which connects the display with the PCB. This is extremely delicate and if disconnected incorrectly, or connected incorrectly, either or both the display or the PCB connector can be irreversibly damaged. Do not take this warning lightly. This will void your warranty.
- Displays are susceptible to mechanical shock and any excessive force exerted on the module may result in deformed zebra stripes, a cracked display cell and broken backlight
- Always use the mounting holes on the module's corner plates to mount the display.

9. Software & Libraries

9.1. UECIDE Programming IDE

The UECIDE Programming IDE is the recommended programming IDE for the Picadillo-35T, and features a plugin specifically for the Picadillo-35T, allowing the display module to be selected and programmed without the need to download separate core files and set them up.

The UECIDE is a free application developed by Majenko Technologies, and is available for download from the UECIDE website, www.uecide.org.

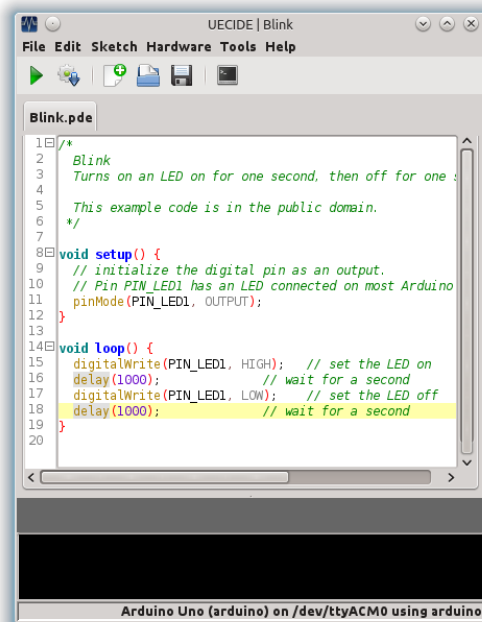

UECIDE is available for download for PC, MAC and Linux Operating Systems, providing flexibility for the operating system of your choice.

9.2. Libraries

The Picadillo-35T is also compatible with the TFT and supporting library, written by Majenko Technologies, which is available for download from their Github Repository, <https://github.com/TFTLibraries>

This library provides both basic and advanced graphics features, and allows you to rapidly develop your application without the need to worry about writing low level TFT Graphics code yourself.

Provided with the TFT Library, are a range of demo applications specifically written for the Picadillo-35T, which demonstrate some of the features of the display module.

A repository of Fonts is also available from Majenko Technologies, available for download from here: <https://github.com/TFTFonts>

Other libraries, such as BMPFile, and Widgets are also available from Majenko Technologies TFTLibraries Github repository, which are compatible with the Picadillo-35T

9.3. Bootloader

The Picadillo-35T utilises a bootloader which enables the PIC32 Processor to be programmed using the on board FTDI USB to Serial IC, by simply connecting a USB cable between your PC and the Picadillo-35T. If however you wish to change the bootloader, simply connect a suitable programming device on to the ICSP headers, such as the PICKit3, and program the PIC32 as required.

Note: On the PICKit3 Programmer, the 3.3V Output to 'Power Target Circuit from Tool' must be enabled else the programmer will not see the PIC32 processor, even though this 3.3V is not used to power the Picadillo-35T itself.

The bootloader for the Picadillo-35T is available for download from the Picadillo-35T product page on the 4D Systems website, www.4dsystems.com.au

12. Mechanical Details

Picadillo-35T Display Module

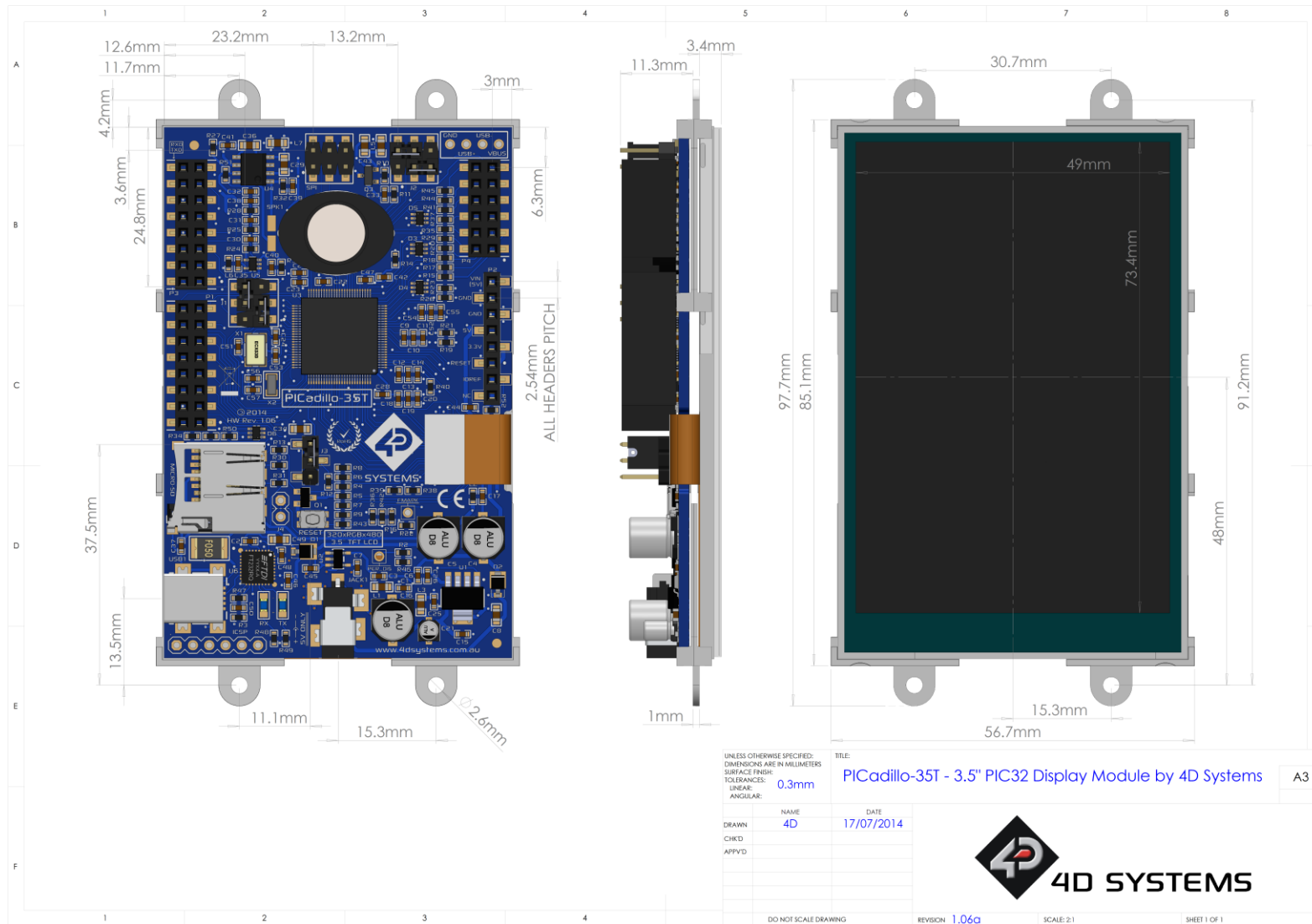

13. Schematic Diagram

Picadillo-35T Display Module

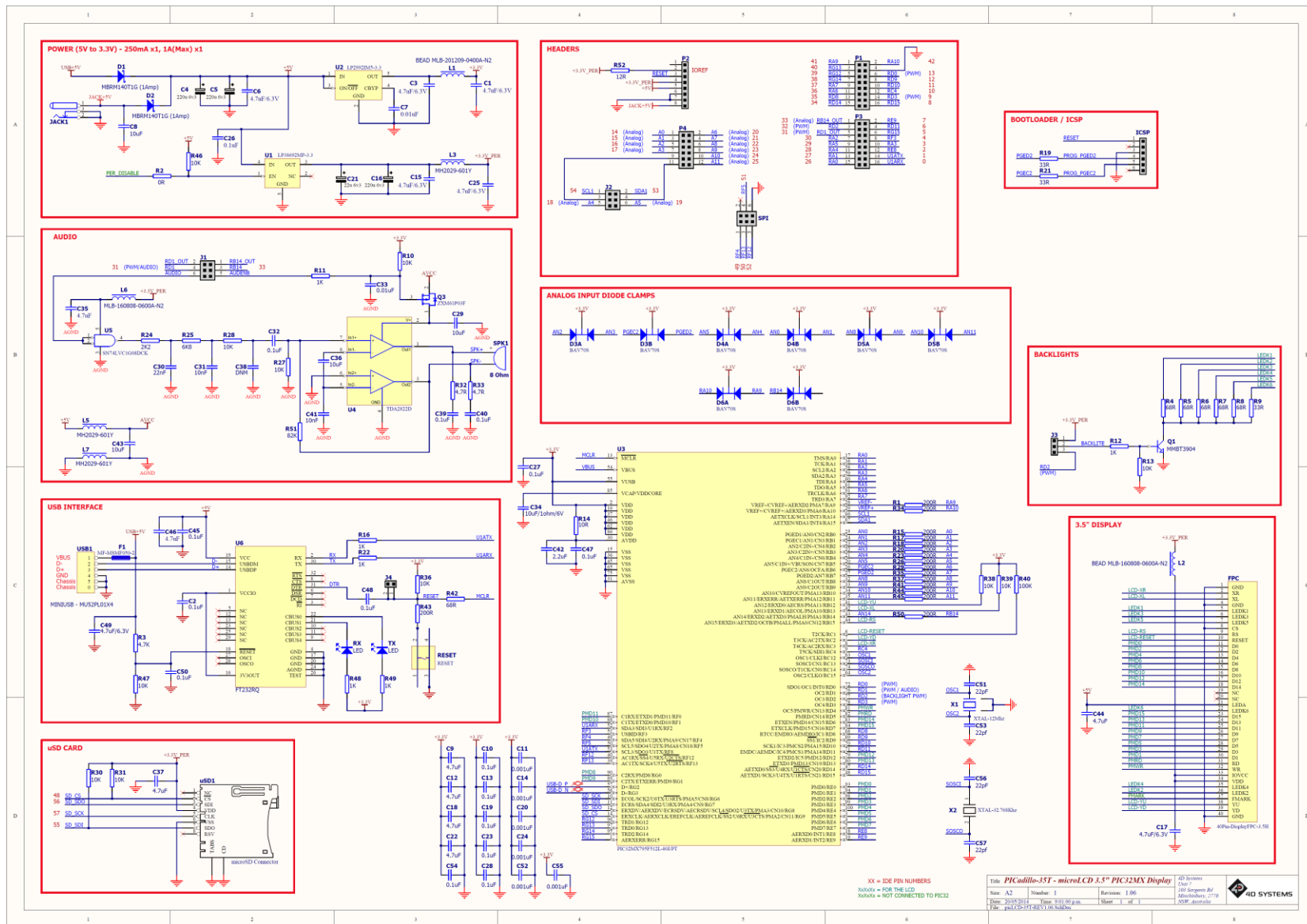

14. Specifications and Ratings

ABSOLUTE MAXIMUM RATINGS

Operating ambient temperature	-15°C to +65°C
Storage temperature	-30°C to +70°C
Voltage on any digital input pin with respect to GND	-0.3V to 5.5V
Voltage on any analog input pin with respect to GND.....	0V to 3.8V
Voltage on VCC with respect to GND	-0.3V to 5.5V
Maximum current sunk/sourced by any pin (More detail please refer to Microchip Datasheet).....	18.0mA
Maximum current sunk/sourced across all pins simultaneously.....	200.0mA

NOTE: Stresses above those listed here may cause permanent damage to the device. This is a stress rating only and functional operation of the device at those or any other conditions above those indicated in the recommended operation listings of this specification is not implied. Exposure to maximum rating conditions for extended periods may affect device reliability. Please refer to the Microchip Datasheet for more information.

RECOMMENDED OPERATING CONDITIONS

Parameter	Conditions	Min	Typ	Max	Units
Supply Voltage (VCC)	Stable external supply required	4.5	5.0	5.5	V
Operating Temperature		-10	--	+60	°C
Input Low Voltage (VIL)	3.3V, all pins	0	--	0.2VCC	V
Input High Voltage (VIH)	3.3V, non 5V tolerant pins	0.8VCC	--	3.3	V
Input High Voltage (VIH)	All GPIO pins, RX0 and TX0 pins	0.8VCC	--	5.5	V
Reset Pulse	External Open Collector	2.0	--	--	µs
Operational Delay	Power-Up or External Reset	500	--	3000	ms

GLOBAL CHARACTERISTICS BASED ON OPERATING CONDITIONS

Parameter	Conditions	Min	Typ	Max	Units
Supply Current (ICC)	5.0V, heavily depends on screen usage conditions, sleep mode, audio, SD card	--	250	--	mA
Output Low Voltage (VOL)	3.3V, IOL = 7.0mA	--	--	0.4	V
Output High Voltage (VOH)	3.3V, IOL = -12.0mA	2.4	--	--	V
Capacitive Loading	All pins	--	--	50	pF
Flash Memory Endurance		--	1000	--	E/W
Display Endurance	Hours of operation, typical		20000		H

ORDERING INFORMATION

Order Code: Picadillo-35T

Packaging: Module sealed in an antistatic foam padded 4D Systems box

15. Revisions

Revision	Revision Content	Date
1.2	Initial Public Release	16/06/2014
1.3	Updated drawing, slight error with AA placement on display	17/07/2014
1.4	Modified Github repository paths as they changed	13/09/2014
1.5	Name Change	19/09/2014

16. Legal Notice

Proprietary Information

The information contained in this document is the property of 4D Systems Pty. Ltd. and may be the subject of patents pending or granted, and must not be copied or disclosed without prior written permission.

4D Systems endeavours to ensure that the information in this document is correct and fairly stated but does not accept liability for any error or omission. The development of 4D Systems products and services is continuous and published information may not be up to date. It is important to check the current position with 4D Systems. 4D Systems reserves the right to modify, update or make changes to Specifications or written material without prior notice at any time.

All trademarks belong to their respective owners and are recognised and acknowledged.

Disclaimer of Warranties & Limitation of Liability

4D Systems makes no warranty, either expressed or implied with respect to any product, and specifically disclaims all other warranties, including, without limitation, warranties for merchantability, non-infringement and fitness for any particular purpose.

Information contained in this publication regarding device applications and the like is provided only for your convenience and may be superseded by updates. It is your responsibility to ensure that your application meets with your specifications.

Images and graphics used throughout this document are for illustrative purposes only. All images and graphics used are possible to be displayed on the 4D Systems range of products, however the quality may vary.

In no event shall 4D Systems be liable to the buyer or to any third party for any indirect, incidental, special, consequential, punitive or exemplary damages (including without limitation lost profits, lost savings, or loss of business opportunity) arising out of or relating to any product or service provided or to be provided by 4D Systems, or the use or inability to use the same, even if 4D Systems has been advised of the possibility of such damages.

4D Systems products are not fault tolerant nor designed, manufactured or intended for use or resale as on line control equipment in hazardous environments requiring fail – safe performance, such as in the operation of nuclear facilities, aircraft navigation or communication systems, air traffic control, direct life support machines or weapons systems in which the failure of the product could lead directly to death, personal injury or severe physical or environmental damage ('High Risk Activities'). 4D Systems and its suppliers specifically disclaim any expressed or implied warranty of fitness for High Risk Activities.

Use of 4D Systems' products and devices in 'High Risk Activities' and in any other application is entirely at the buyer's risk, and the buyer agrees to defend, indemnify and hold harmless 4D Systems from any and all damages, claims, suits, or expenses resulting from such use. No licenses are conveyed, implicitly or otherwise, under any 4D Systems intellectual property rights.

17. Contact Information

For Technical Support: support@4dsystems.com.au

For Sales Support: sales@4dsystems.com.au

Website: www.4dsystems.com.au

Copyright 4D Systems Pty. Ltd. 2000-2014.