

Ultra High Precision LED Bulk Metal® Foil Resistors  
Rating to 8W, TCR of  $\pm 0.2$  ppm/°C and Stability of  $\pm 0.005\%$

FEATURES AND BENEFITS

- Temperature coefficient of resistance (TCR) (Table 1):
  - 0.05 ppm/°C nominal (0°C to +60°C)
  - $\pm 0.2$  ppm/°C nominal (-55°C to +125°C, +25°C ref.)
- Resistance range: **0.3  $\Omega$  to 500  $\Omega$**  (for higher and lower values, please contact us)
- Bulk Metal Foil resistors are not restricted to standard values; we can supply specific “as required” values at no extra cost or delivery (e.g., 50R1234 vs. 50  $\Omega$ )
- Resistance tolerance: to  $\pm 0.01\%$
- Power coefficient “ $\Delta R$  due to self heating”: 5 ppm at rated power
- Load life stability:  $\pm 0.005\%$  (50 ppm)
- Electrostatic discharge (ESD): at least to 25 kV
- Thermal stabilization time: <1 s (within 10 ppm of steady state value)
- Power rating: LED1625 to 1 W; LED221 to 8 W (Table 2)
- Non-inductive, non-capacitive design
- Rise time: 1 ns effectively no ringing
- Current noise: 0.010  $\mu V_{RMS}/V$  of applied voltage <-40 dB
- Voltage coefficient: <0.1 ppm/V
- Non-inductive: <0.08  $\mu H$
- Non hot spot design
- Thermal EMF: <0.05  $\mu V/^\circ C$
- Low harmonic distortion, linear behavior
- **LED221 is available with a solderable heat-sink tab (Ni/Tin-plated)**



For improved LED brightness.

INTRODUCTION

In the modern LED-backed LCD, screen brightness is a very important function. The brightness is obtained by the LED panel mounted to the rear of the LCD, which controls brightness by boosting the input voltage connected to the panel. The input voltage usually comes from an Li-ion battery. A boost converter converts the Li-ion battery voltage to dozens of volts for the LED panel operation. To avoid brightness flickering and to control the stability of the LED output voltage, stable and precise current sense resistors with low thermal EMF and low absolute temperature coefficient of resistance are used.

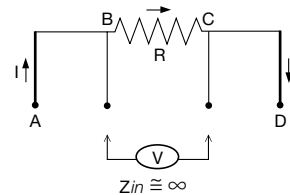
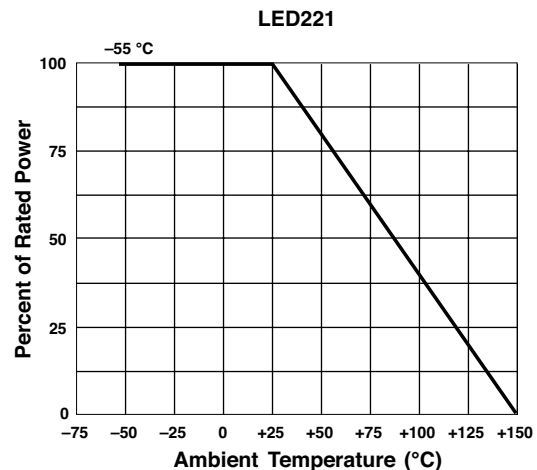
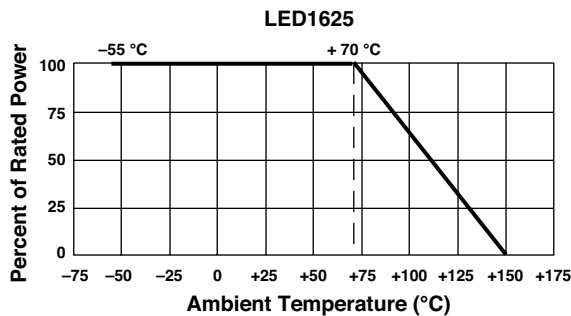


Figure 1 – Power Derating Curves



Note

\* This datasheet provides information about parts that are RoHS-compliant and/or parts that are non-RoHS-compliant. For example, parts with lead (Pb) terminations are not RoHS compliant. Please see the information/tables in this datasheet for details.

# New LED Resistors (LED1625 and LED221)

Table 1a—Specifications <sup>(1)</sup>					
Model Number	Resistance Range (Ω)	Tolerance <sup>(2)</sup> (%)	Nominal TCR and Max. Spread (-55°C to +125°C, +25°C Ref.) (ppm/°C)	Power Rating @ +70°C	Maximum Current <sup>(3)</sup>
LED1625	>2.0 to 10	±0.2%	0.2 ±2.8	1 W on FR4 PCB <sup>(4)</sup>	1.8 A
		±0.5%			
		±1.0%			
	0.3 to 2.0	±0.5%			
		±1.0%			

**Notes**  
<sup>(1)</sup> Tighter performances are available. Please contact us: foil@vpgsensors.com.  
<sup>(2)</sup> 0.05% and 0.1% are also available per special request.  
<sup>(3)</sup> Power, current—whichever is lower.  
<sup>(4)</sup> See solder pad layout in Figure 5a.

Table 1b—Specifications			
Model Number	Resistance Range (Ω)	Tightest Tolerance <sup>(2)</sup> (%)	Nominal TCR and Max. Spread <sup>(1)</sup> (ppm/°C)
LED221	0.5 to <1	±0.05%	±0.2 ±2.8
	1 to <10	±0.02%	±0.2 ±2.3
	10 to 500	±0.01%	±0.2 ±1.8

**Note**  
<sup>(1)</sup> MIL-Range (-55°C to +125°C, +25°C Ref.)

## THE LED PRECISION RESISTORS

Direct control of current is provided by current sensing foil resistors. LEDs are current-driven devices whose brightness is proportional to their forward current. Forward current can be controlled in two ways. The first method is to use the LED V-I curve to determine what voltage needs to be applied to the LED to generate the desired forward current. This is typically accomplished by applying a voltage source and using a ballast resistor as shown in Figure 2. However, this method has several drawbacks. Any change in LED forward voltage creates a change in LED current. With a nominal forward battery voltage of 3.6 V, the LED in Figure 2 has 20 mA of current. If this voltage changes to 4.0 V, which is within the specified voltage tolerance due to temperature or manufacturing changes, the forward current drops to 14 mA. This 11% change in forward voltage causes a much larger 30 % change in forward current. Also, depending upon the available input voltage, the voltage drop and power dissipation across the ballast resistor waste power and reduce battery life.

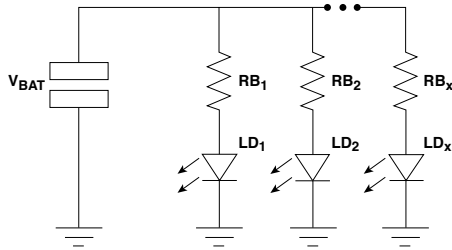
The second, preferred method of regulating LED current is to drive the LED with a constant current source. The constant current source eliminates changes in current due to variations in forward voltage, which translates into a constant LED brightness. Generating a constant current source is fairly simple. Rather than regulating the output voltage, the input power supply regulates the voltage across a current sense resistor. Figure 3 shows this implementation. The power supply reference voltage and the value of the current sense resistor determine the LED

current. Multiple LEDs should be connected in a series configuration to keep an identical current flowing in each LED. Driving LEDs in parallel requires a ballast resistor in each LED string, which leads to lower efficiency and uneven current matching.

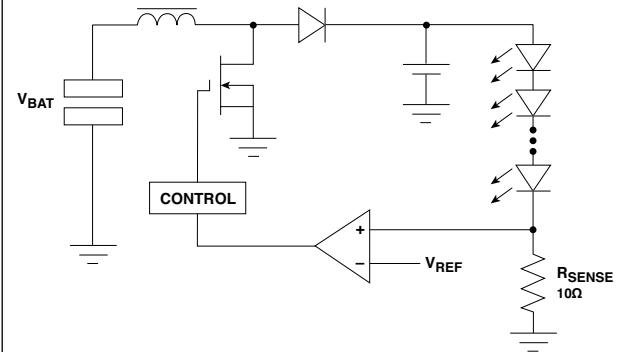
Battery life is critical in portable applications. For an LED driver to be useful, it must be efficient. Power efficiency is largely determined by the precision of the current sensing and brightness control. The amount of input power required to generate the desired LED brightness can be easily determined by dividing the power in the LEDs by the input power. Defining the efficiency in this way means that the power dissipated in the current sensing resistor contributes to the power lost in the power supply. Therefore, it is very important to use VPG's high-precision current sense resistors. In the case of a preferable and calculated value of 10 Ω, the best choice is the LED1625 or LED221 10 Ω resistor with 0.1% tolerance.

Figure 4 shows a typical LED driver application that drives a number of LEDs with 20 mA of forward current and operates from an input voltage range of 2.8 V to 6.0 V. The entire circuit consists of the control IC, two small ceramic capacitors, an inductor, a diode, and a 10 Ω current sense resistor. For this application, the LED1625 or LED221 10 Ω resistor would be ideal. This small circuit shows the high level of integration that is achieved with today's LED drivers. The primary power supply functions and the secondary features such as load disconnect, overvoltage protection, and PWM dimming have been implemented with a control IC and five small surface-mount passive components.

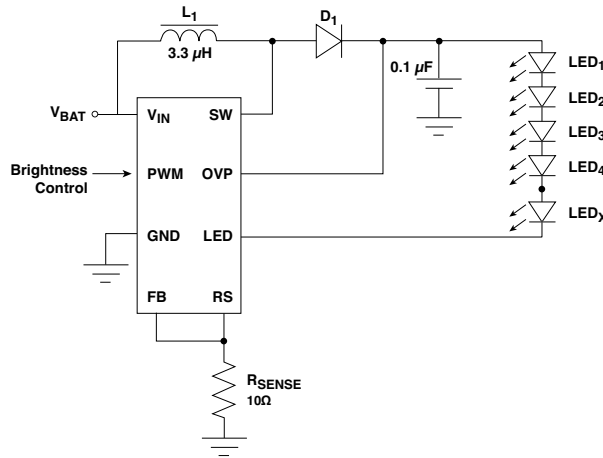
**Figure 2—Voltage Source with Ballast Resistors**



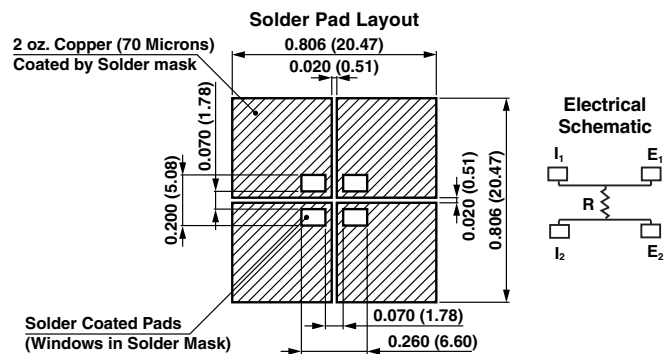
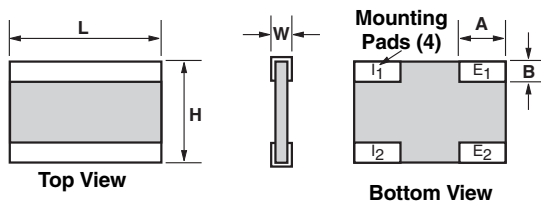
**Figure 3—Constant Current Source for Driving LEDs**



**Figure 4—Typical LED Driver Solution**

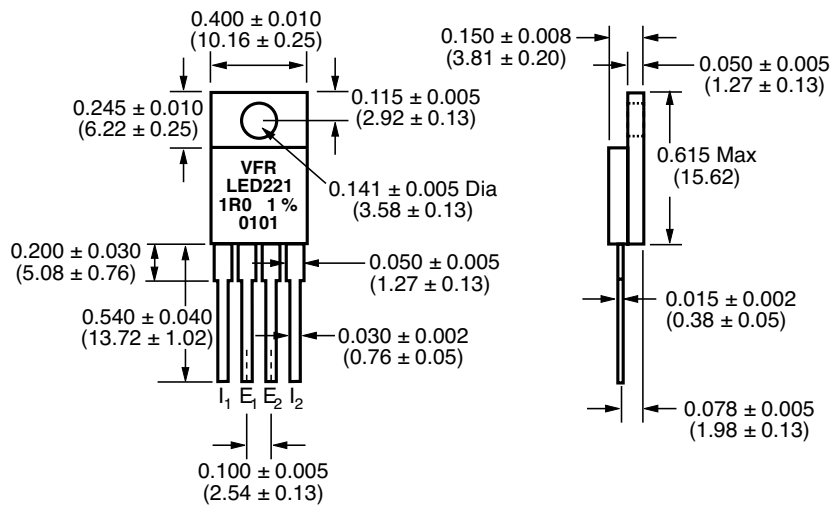


**Figure 5a—LED1625 Dimensions in Inches (Millimeters)**

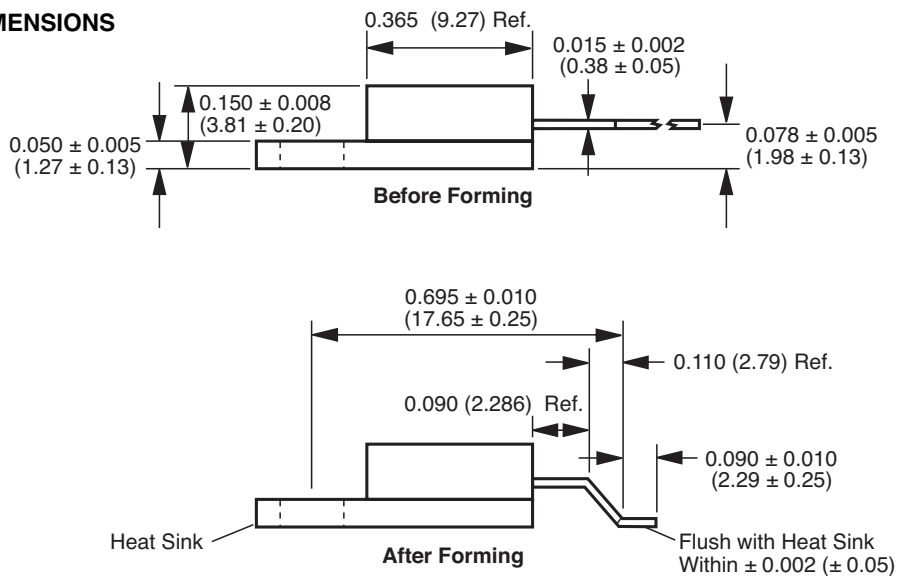


Dimension	inches	millimeters
L	0.250 ±0.010	6.35 ±0.25
H	0.160 ±0.010	4.06 ±0.25
W	0.040 maximum	1.02 maximum
A	0.080 ±0.005	2.03 ±0.13
B	0.040 ±0.010	1.02 ±0.25

**Figure 5b—LED221 Dimensions in Inches (Millimeters)**



## FORMING DIMENSIONS



## LAND PATTERN DIMENSIONS

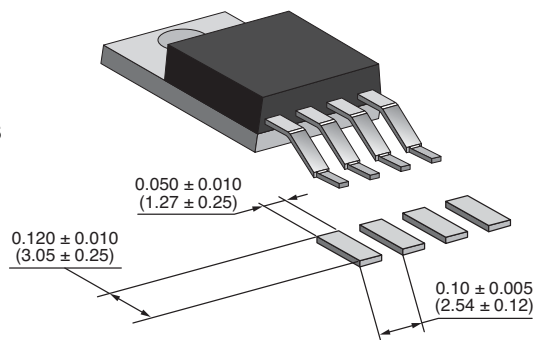


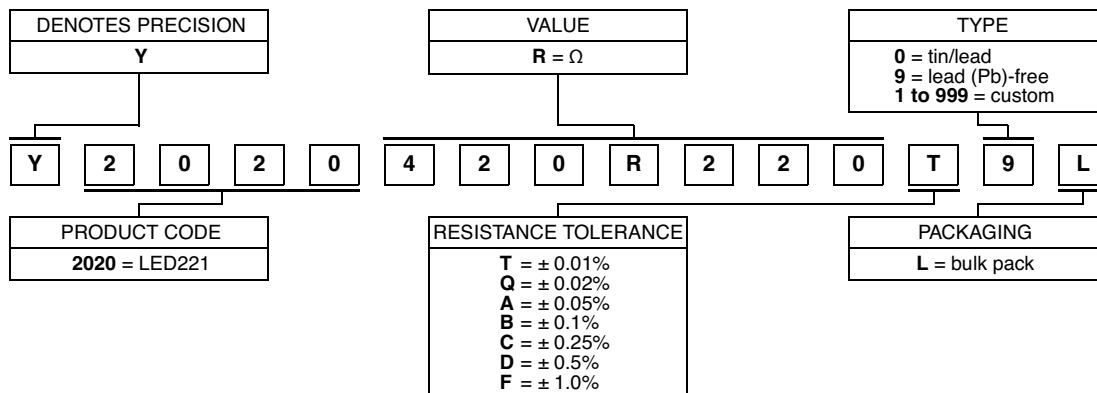
Table 2—LED221 Specifications																	
Test or Condition	Performance																
Power rating at +25°C	8 W or 3 A <sup>(1)</sup> on heat sink <sup>(2)</sup> 1.5 W in free air																
Current noise	<0.010 $\mu$ V <sub>RMS</sub> /V of applied voltage (-40 dB)																
High frequency operation Rise time Inductance <sup>(3)</sup> (L) Capacitance (C)	0.2 ns at 1 W 0.1 $\mu$ H maximum: 0.03 $\mu$ H typical <sup>(4)</sup> 1.0 pF maximum: 0.5 pF typical <sup>(4)</sup>																
Voltage coefficient <sup>(5)</sup>	<0.1 ppm/V																
Operating temperature range	-55°C to +150°C																
Maximum working voltage	300 V, not to exceed power rating																
Thermal EMF <sup>(6)</sup>	0.15 $\mu$ V/°C maximum (lead effect)																
Weight	1.2 g maximum																
<b>Notes</b> <sup>(1)</sup> Whichever is lower. <sup>(2)</sup> Heat sink chassis dimensions are requirements per MIL-R-39009/1B: <table border="1" data-bbox="188 798 774 976"> <thead> <tr> <th>Dimension</th> <th>inches</th> <th>millimeter</th> </tr> </thead> <tbody> <tr> <td>L</td> <td>6.00</td> <td>152.4</td> </tr> <tr> <td>W</td> <td>4.00</td> <td>101.6</td> </tr> <tr> <td>H</td> <td>2.00</td> <td>50.8</td> </tr> <tr> <td>T</td> <td>0.04</td> <td>1.0</td> </tr> </tbody> </table> <sup>(3)</sup> Inductance (L) mainly due to the leads. <sup>(4)</sup> Maximum is 1.0 % A.Q.L. standard for all specifications except TCR. <sup>(5)</sup> The resolution limit of existing test requirement (within the measurement capability of the equipment, “essentially zero”). <sup>(6)</sup> $\mu$ V/°C relates to EMF due to lead temperature difference.			Dimension	inches	millimeter	L	6.00	152.4	W	4.00	101.6	H	2.00	50.8	T	0.04	1.0
Dimension	inches	millimeter															
L	6.00	152.4															
W	4.00	101.6															
H	2.00	50.8															
T	0.04	1.0															

Table 3—Performance Specifications		
Test or Condition	$\Delta$ R Limits Typical	$\Delta$ R Limits Max <sup>(1)</sup>
<b>LED1625</b>		
Thermal shock, 5 x (-65°C to +150°C)	$\pm$ 0.005% (50 ppm)	$\pm$ 0.01% (100 ppm)
Low temperature operation, -65°C, 45 min at P <sub>nom</sub>	$\pm$ 0.005% (50 ppm)	$\pm$ 0.01% (100 ppm)
Short time overload, 6.25 x rated power, 5 s	$\pm$ 0.005% (50 ppm)	$\pm$ 0.02% (200 ppm)
High temperature exposure, +150°C, 100 h	$\pm$ 0.01% (100 ppm)	$\pm$ 0.02% (200 ppm)
Resistance to soldering heat	$\pm$ 0.01% (100 ppm)	$\pm$ 0.03% (300 ppm)
Moisture resistance	0.01% (100 ppm)	$\pm$ 0.03% (300 ppm)
Load life stability, +70°C for 2000 h at 1 W	0.015% (150 ppm)	$\pm$ 0.025% (250 ppm)
<b>LED221</b>		
Low temperature storage, 24 hours at -55°C	$\pm$ 0.001 % (10 ppm)	$\pm$ 0.002 % (20 ppm)
Dielectric withstanding voltage, 300 V AC at Atm	$\pm$ 0.001 % (10 ppm)	$\pm$ 0.002 % (20 ppm)
Dielectric withstanding voltage, 200 V AC at Brm	$\pm$ 0.001 % (10 ppm)	$\pm$ 0.002 % (20 ppm)
Insulation resistance		$\pm$ 10 <sup>4</sup> M $\Omega$
Low temperature operation	$\pm$ 0.002 % (20 ppm)	$\pm$ 0.008% (80 ppm)
Short time overload, 5 x rated power, 5 s (in air)	$\pm$ 0.001% (10 ppm)	$\pm$ 0.002 % (20 ppm)
Moisture resistance, +65°C to -10°C, 90 to 98 Rh, 10 days	$\pm$ 0.005% (50 ppm)	$\pm$ 0.015 % (150 ppm)
Terminal Strength	$\pm$ 0.001% (10 ppm)	$\pm$ 0.002 % (20 ppm)
Load life, +25°C for 2000 h with heat sink at 8 W	$\pm$ 0.005% (50 ppm)	$\pm$ 0.015 % (150 ppm)
Load life, +25°C for 2000 h in free air at 1.5 W	$\pm$ 0.005% (50 ppm)	$\pm$ 0.015 % (150 ppm)
High temperature exposure, +150°C	$\pm$ 0.005% (50 ppm)	$\pm$ 0.01% (100 ppm)
<b>Notes</b> <sup>(1)</sup> Measurement error $\pm$ 0.001 $\Omega$ .		

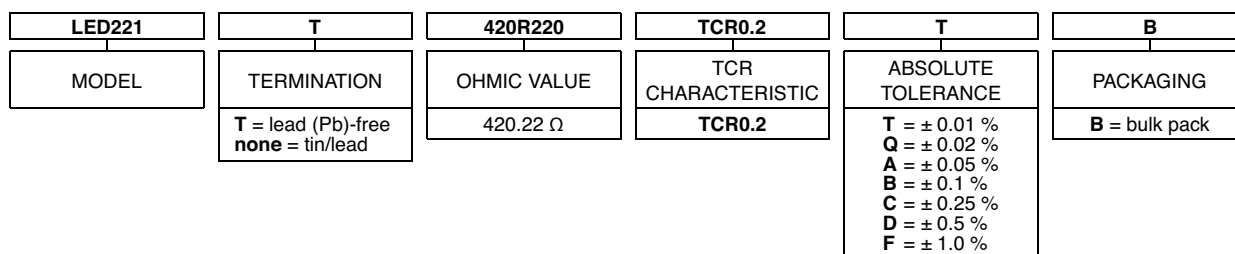
# New LED Resistors (LED1625 and LED221)

**Figure 6—LED221 and LED1625 Part Number Information <sup>(1)</sup>**

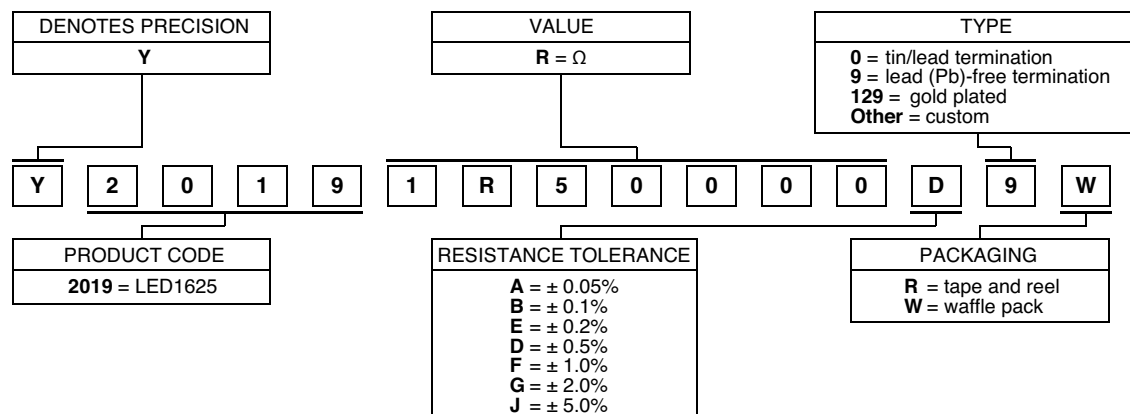
LED221 GLOBAL PART NUMBER: Y2020420R220T9L



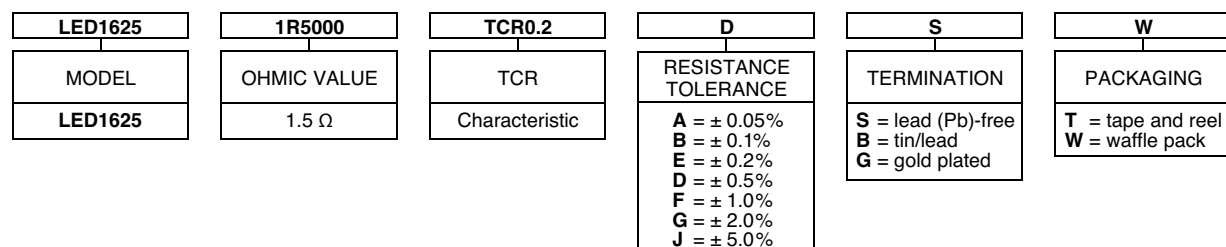
PART DESCRIPTION: LED221T 420R220 TCR0.2 T B



LED1625 GLOBAL PART NUMBER: Y20191R5000D9W



PART DESCRIPTION: LED1625 1R5000 TCR0.2 D S W



**Note**

<sup>(1)</sup> For non-standard requests, please contact Application Engineering.



## Disclaimer

ALL PRODUCTS, PRODUCT SPECIFICATIONS AND DATA ARE SUBJECT TO CHANGE WITHOUT NOTICE.

Vishay Precision Group, Inc., its affiliates, agents, and employees, and all persons acting on its or their behalf (collectively, "VPG"), disclaim any and all liability for any errors, inaccuracies or incompleteness contained herein or in any other disclosure relating to any product.

The product specifications do not expand or otherwise modify VPG's terms and conditions of purchase, including but not limited to, the warranty expressed therein.

VPG makes no warranty, representation or guarantee other than as set forth in the terms and conditions of purchase. **To the maximum extent permitted by applicable law, VPG disclaims (i) any and all liability arising out of the application or use of any product, (ii) any and all liability, including without limitation special, consequential or incidental damages, and (iii) any and all implied warranties, including warranties of fitness for particular purpose, non-infringement and merchantability.**

Information provided in datasheets and/or specifications may vary from actual results in different applications and performance may vary over time. Statements regarding the suitability of products for certain types of applications are based on VPG's knowledge of typical requirements that are often placed on VPG products. It is the customer's responsibility to validate that a particular product with the properties described in the product specification is suitable for use in a particular application. You should ensure you have the current version of the relevant information by contacting VPG prior to performing installation or use of the product, such as on our website at [vpgsensors.com](http://vpgsensors.com).

No license, express, implied, or otherwise, to any intellectual property rights is granted by this document, or by any conduct of VPG.

The products shown herein are not designed for use in life-saving or life-sustaining applications unless otherwise expressly indicated. Customers using or selling VPG products not expressly indicated for use in such applications do so entirely at their own risk and agree to fully indemnify VPG for any damages arising or resulting from such use or sale. Please contact authorized VPG personnel to obtain written terms and conditions regarding products designed for such applications.

Product names and markings noted herein may be trademarks of their respective owners.

Copyright Vishay Precision Group, Inc., 2014. All rights reserved.