

● DISCRETE LEDs - Ø 5mm RED

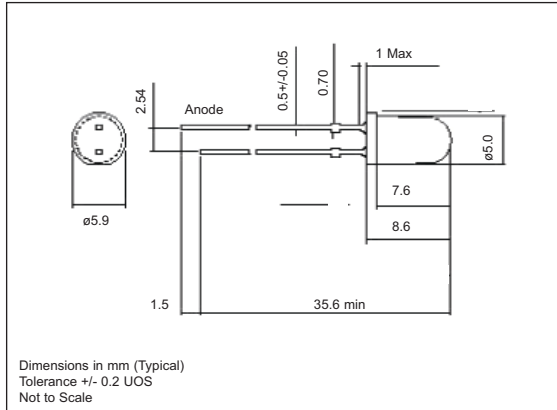

- Solid state reliability
- Also available as a 3mm device and in SMT format
- Part of a range of other high intensity colours



110069 SERIES

Ordering Information & Typical Technical Characteristics (Ta = 25°C)

* Duty Cycle <= 1/10, Pulse Width <= 10msec

PART NUMBER	COLOUR	TYP. FWD VOLTAGE Vf@Iopr	MAX FWD VOLTAGE Vf@Iopr	FORWARD CURRENT Iopr	MAX REV CURRENT Ir(Vr=5V)	TYPICAL LUMINOUS INTENSITY Iv@Iopr	TYPICAL CHROMATICITY COORDINATES @Iopr	VIEWING ANGLE 2θ½
OPTICAL/ELECTRICAL CHARACTERISTICS (Ta = 25°C)								
110069	Red	1.85	2.5	30	10	2800	0.31/0.32	20
UNITS	Water Clear	V	V	mA	uA	mcd	x / y	deg

PART NUMBER	COLOUR	FORWARD CURRENT Iopr max	PEAK FWD CURRENT Ifp *	REVERSE VOLTAGE Vr max	POWER DISSIPATION P dmax	PEAK WAVELENGTH Typ. λp	OPERATING TEMP Topr	STORAGE TEMP Tstg
ABSOLUTE MAXIMUM RATINGS (Ta = 25°C)								
110069	Red	30	155	5	100	660	-40 to +85	-40 to +100
UNITS	Water Clear	mA	mA	Vdc	mW	nm	°C	°C

PRECAUTIONS FOR HANDLING ELECTROSTATIC SENSITIVE LEDs

Static Electricity and Surge

Static electricity and surge will damage the LED and a high standard of care must be taken during handling. It is recommended that a wristband, conductive mat or anti-electrostatic glove is used when handling the LEDs. All devices, equipment (e.g. soldering iron points) and machinery must be properly grounded.

SAFETY PRECAUTIONS FOR HANDLING HIGH BRIGHTNESS LEDs

The light output of the Products may cause injuries to human eyes in circumstances where they are viewed directly with unshielded eyes for more than a few seconds.

Please refer to European Standard BSEN 100015-1 1992 for further information.