

DATA SHEET

For a complete data sheet, please also download:

- The IC06 74HC/HCT/HCU/HCMOS Logic Family Specifications
- The IC06 74HC/HCT/HCU/HCMOS Logic Package Information
- The IC06 74HC/HCT/HCU/HCMOS Logic Package Outlines

74HC/HCT280 9-bit odd/even parity generator/checker

Product specification
File under Integrated Circuits, IC06

December 1990

9-bit odd/even parity generator/checker

74HC/HCT280

FEATURES

- Word-length easily expanded by cascading
- Similar pin configuration to the "180" for easy system up-grading
- Generates either odd or even parity for nine data bits
- Output capability: standard
- I_{CC} category: MSI

GENERAL DESCRIPTION

The 74HC/HCT280 are high-speed Si-gate CMOS devices and are pin compatible with low power Schottky TTL (LSTTL). They are specified in compliance with JEDEC standard no. 7A.

The 74HC/HCT280 are 9-bit parity generators or checkers commonly used to detect errors in high-speed data

transmission or data retrieval systems. Both even and odd parity outputs are available for generating or checking even or odd parity up to 9 bits.

The even parity output (Σ_E) is HIGH when an even number of data inputs (I_0 to I_8) are HIGH. The odd parity output (Σ_O) is HIGH when an odd number of data inputs are HIGH.

Expansion to larger word sizes is accomplished by tying the even outputs (Σ_E) of up to nine parallel devices to the data inputs of the final stage. For a single-chip 16-bit even/odd parity generator/checker, see PC74HC/HCT7080.

APPLICATIONS

- 25-line parity generator/checker
- 81-line parity generator/checker

QUICK REFERENCE DATA

GND = 0 V; T_{amb} = 25 °C; t_r = t_f = 6 ns

SYMBOL	PARAMETER	CONDITIONS	TYPICAL		UNIT
			HC	HCT	
t _{PHL} / t _{PLH}	propagation delay	C _L = 15 pF; V _{CC} = 5 V			
	I _n to Σ_E		17	18	ns
	I _n to Σ_O		20	22	ns
C _I	input capacitance		3.5	3.5	pF
C _{PD}	power dissipation capacitance per package	notes 1 and 2	65	65	pF

Notes

1. C_{PD} is used to determine the dynamic power dissipation (P_D in μ W):

$$P_D = C_{PD} \times V_{CC}^2 \times f_i + \sum (C_L \times V_{CC}^2 \times f_o) \text{ where:}$$

f_i = input frequency in MHz

f_o = output frequency in MHz

$\sum (C_L \times V_{CC}^2 \times f_o)$ = sum of outputs

C_L = output load capacitance in pF

V_{CC} = supply voltage in V

2. For HC the condition is V_I = GND to V_{CC}
For HCT the condition is V_I = GND to V_{CC} – 1.5 V

ORDERING INFORMATION

See "74HC/HCT/HCU/HCMOS Logic Package Information".

9-bit odd/even parity generator/checker

74HC/HCT280

PIN DESCRIPTION

PIN NO.	SYMBOL	NAME AND FUNCTION
8, 9, 10, 11, 12, 13, 1, 2, 4	I_0 to I_8	data inputs
5, 6	Σ_E, Σ_O	parity outputs
7	GND	ground (0 V)
14	V_{CC}	positive supply voltage

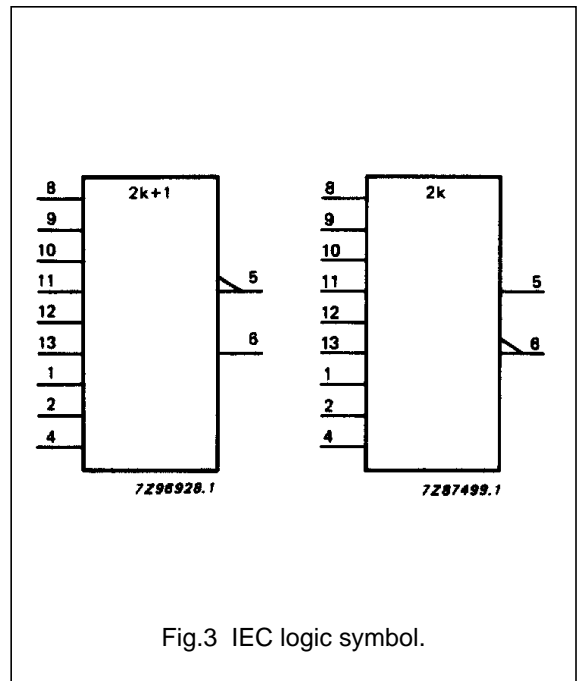
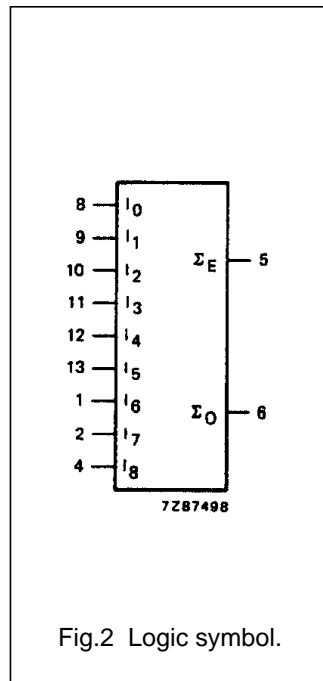
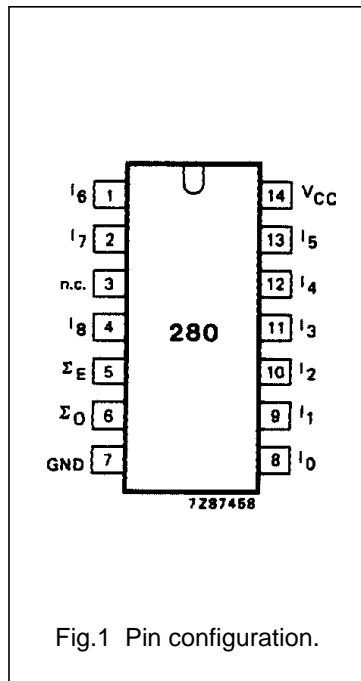

9-bit odd/even parity generator/checker

74HC/HCT280

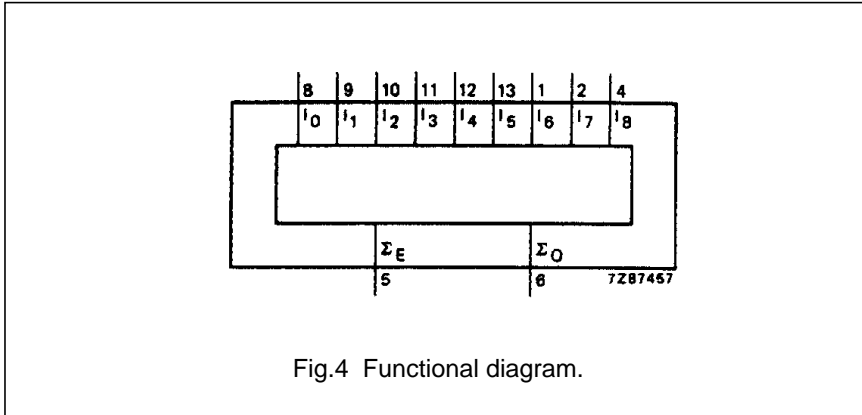

FUNCTION TABLE

INPUTS number of HIGH data inputs (I_0 to I_8)	OUTPUTS	
	ΣE	ΣO
even	H	L
odd	L	H

Note

1. H = HIGH voltage level
L = LOW voltage level

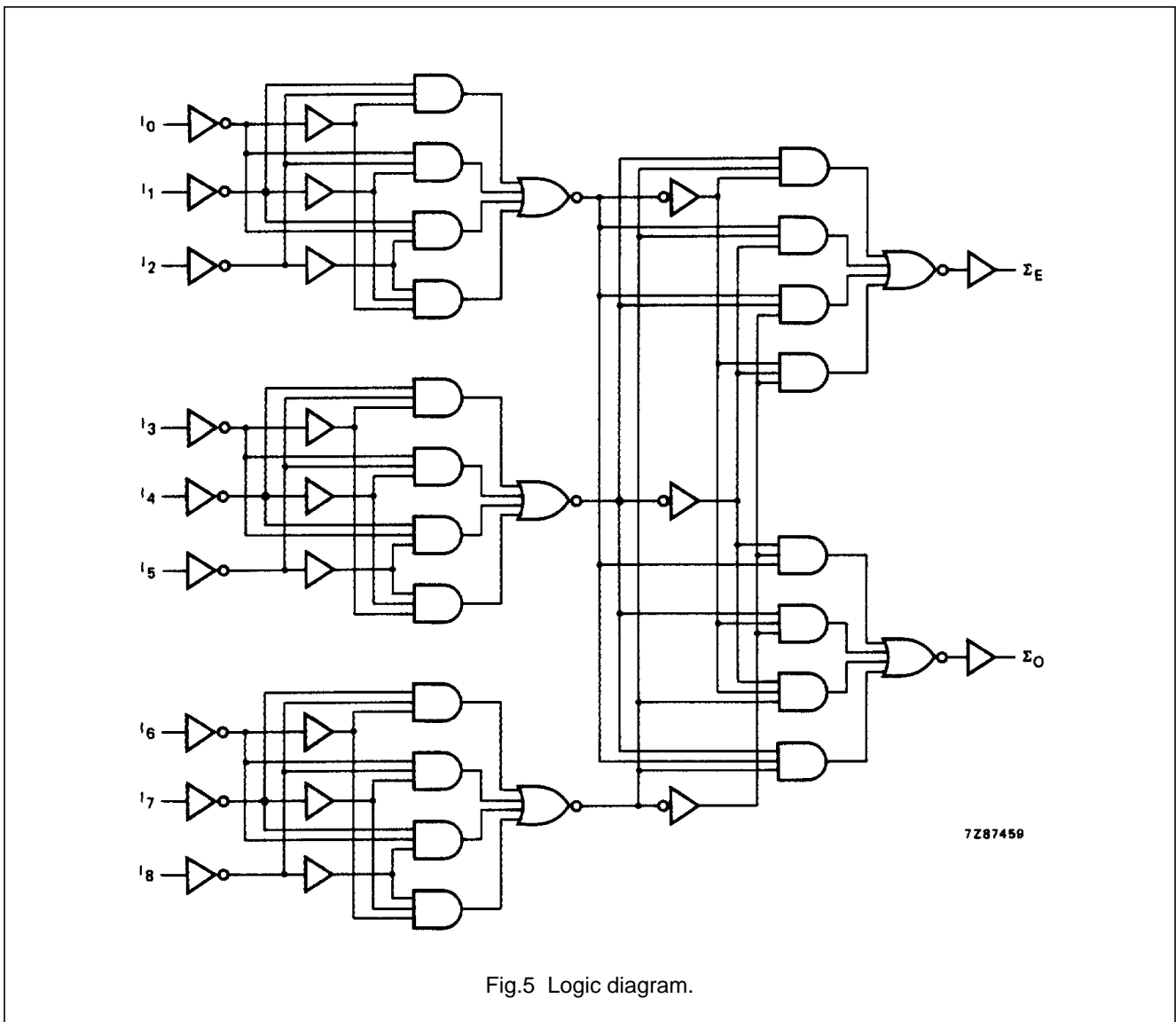

9-bit odd/even parity generator/checker

74HC/HCT280

DC CHARACTERISTICS FOR 74HC

For the DC characteristics see *"74HC/HCT/HCU/HCMOS Logic Family Specifications"*.

Out put capability: standard

I_{CC} category: MSI

AC CHARACTERISTICS FOR 74HC

GND = 0 V; t_r = t_f = 6 ns; C_L = 50 pF

SYMBOL	PARAMETER	T _{amb} (°C)						UNIT	TEST CONDITIONS		
		74HC							V _{CC} (V)	WAVEFORMS	
		+25			-40 to +85		-40 to +125				
		min.	typ.	max.	min.	max.	min.				max.
t _{PHL} / t _{PLH}	propagation delay I _n to Σ _E		55 20 16	200 40 34		250 50 43		300 60 51	ns	2.0 4.5 6.0	Fig.6
t _{PHL} / t _{PLH}	propagation delay I _n to Σ _O		63 23 18	200 40 34		250 50 43		300 60 51	ns	2.0 4.5 6.0	Fig.6
t _{THL} / t _{TLH}	output transition time		19 7 6	75 15 13		95 19 16		110 22 19	ns	2.0 4.5 6.0	Fig.6

9-bit odd/even parity generator/checker

74HC/HCT280

DC CHARACTERISTICS FOR 74HCT

For the DC characteristics see *"74HC/HCT/HCU/HCMOS Logic Family Specifications"*.

Output capability: standard

I_{CC} category: MSI

Note to HCT types

The value of additional quiescent supply current (ΔI_{CC}) for a unit load of 1 is given in the family specifications. To determine ΔI_{CC} per input, multiply this value by the unit load coefficient shown in the table below.

INPUT	UNIT LOAD COEFFICIENT
I _n	1.0

AC CHARACTERISTICS FOR 74HCT

GND = 0 V; t_r = t_f = 6 ns; C_L = 50 pF

SYMBOL	PARAMETER	T _{amb} (°C)						UNIT	TEST CONDITIONS		
		74HCT							V _{CC} (V)	WAVEFORMS	
		+25			-40 to +85		-40 to +125				
		min.	typ.	max.	min.	max.	min.				max.
t _{PHL} / t _{PLH}	propagation delay I _n to Σ_E		21	42		53		63	ns	4.5	Fig.6
t _{PHL} / t _{PLH}	propagation delay I _n to Σ_O		26	45		56		68	ns	4.5	Fig.6
t _{THL} / t _{TLH}	output transition time		7	15		19		22	ns	4.5	Fig.6

9-bit odd/even parity generator/checker

74HC/HCT280

AC WAVEFORMS

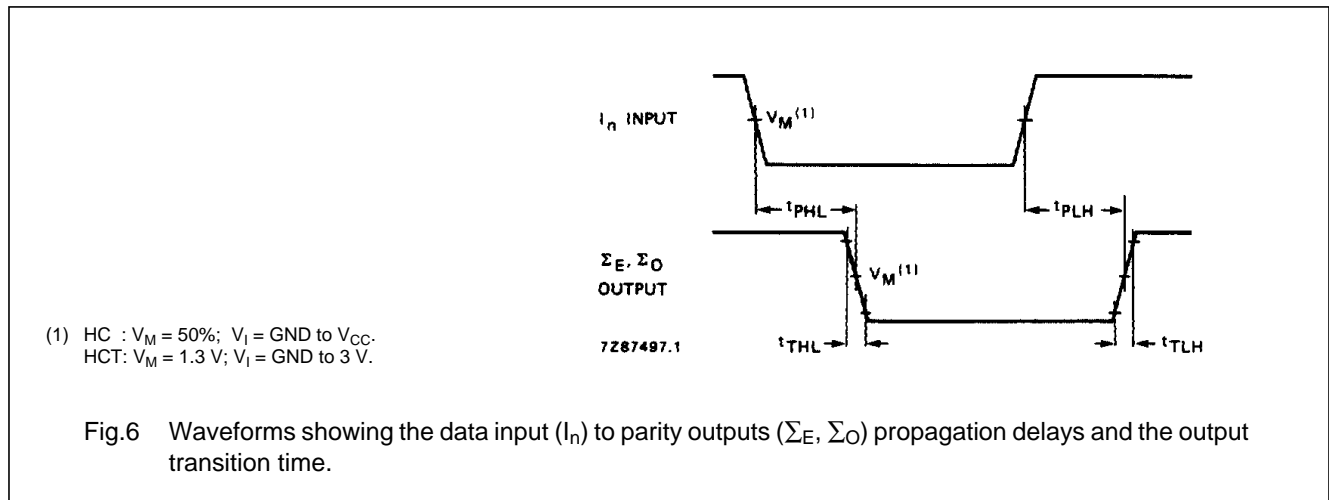

APPLICATION INFORMATION

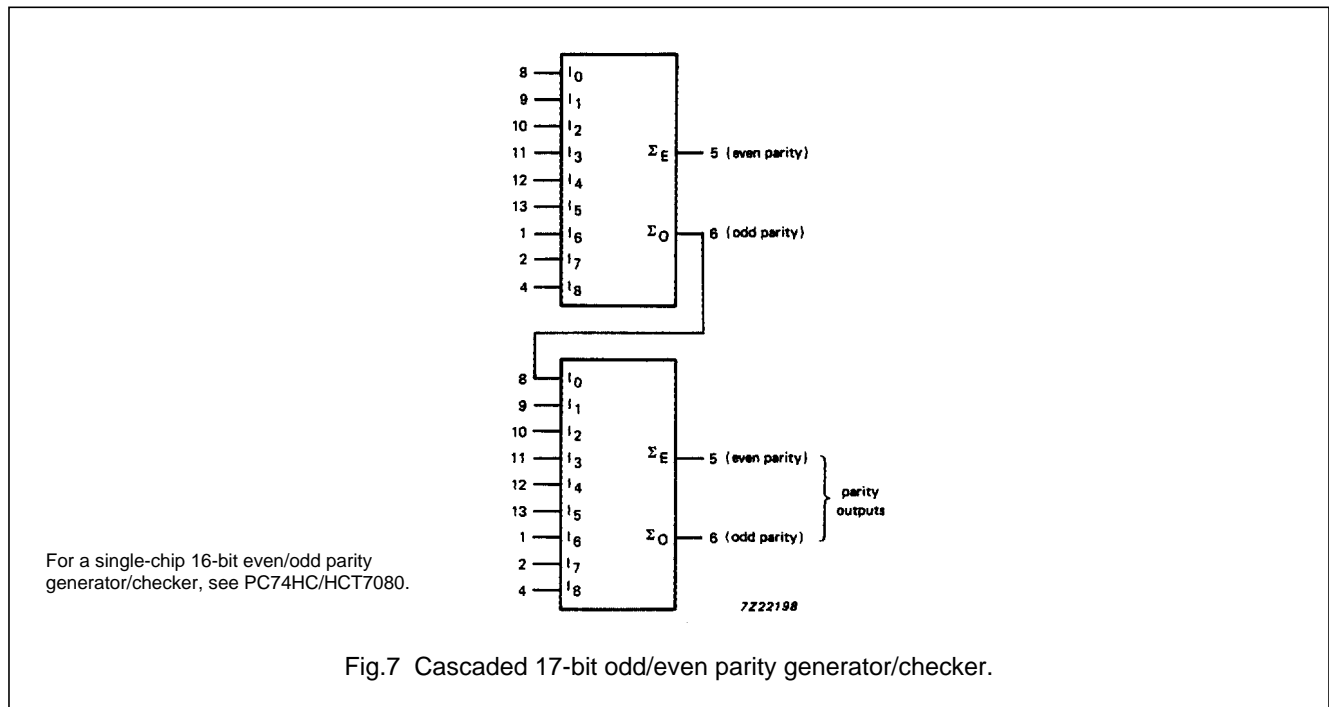

PACKAGE OUTLINES

See "74HC/HCT/HCU/HCMOS Logic Package Outlines".

74HC/HCT280 Packaging Information



Type Number	Orderable Part Number	Package Name
74HC280D	74HC280D,653	SO14
74HC280D	74HC280D,652	SO14
74HC280N	74HC280N,652	DIP14
74HCT280D	74HCT280D,653	SO14
74HCT280D	74HCT280D,652	SO14
74HCT280DB	74HCT280DB,118	SSOP14
74HCT280DB	74HCT280DB,112	SSOP14
74HCT280N	74HCT280N,652	DIP14