

# INFCDT

## INFINITY<sup>®</sup> C Differential Temperature Meter with Thermocouple

### Operator's Manual



**NEWPORT Electronics, Inc.**

<http://www.newportUS.com/manuals>





Additional products from

# NEWPORT Electronics, Inc.

|                  |                |
|------------------|----------------|
| Counters         | Rate Meters    |
| Frequency Meters | Timers         |
| PID Controllers  | Totalizers     |
| Clock/Timers     | Strain Gauge   |
| Printers         | Meters         |
| Process Meters   | Voltmeters     |
| On/Off           | Multimeters    |
| Controllers      | Soldering Iron |
| Recorders        | Testers        |
| Relative         | pH pens        |
| Humidity         | pH Controllers |
| Transmitters     | pH Electrodes  |
| Thermocouples    | RTDs           |
| Thermistors      | Thermowells    |
| Wire             | Flow Sensors   |

For Immediate Assistance

In the U.S.A. and Canada: 1-800-NEWPORT®

In Mexico: (95) 800-NEWPORT<sup>SM</sup>

Or call your local NEWPORT Office.

**NEWPORTnet<sup>SM</sup> On-Line Service**

<http://www.newportUS.com>

**Internet e-mail**

[info@newportUS.com](mailto:info@newportUS.com)

It is the policy of NEWPORT to comply with all worldwide safety and EMC/EMI regulations that apply. NEWPORT is constantly pursuing certification of its products to the European New Approach Directives. NEWPORT will add the CE mark to every appropriate device upon certification.

The information contained in this document is believed to be correct but NEWPORT Electronics, Inc. accepts no liability for any errors it contains, and reserves the right to alter specifications without notice.

**WARNING:** These products are not designed for use in, and should not be used for, patient connected applications.

**TRADEMARK NOTICE:**   **NEWPORT, NEWPORT**, [newportUS.com](http://www.newportUS.com), , , **INFINITY** and the "Meter Case Bezel Design" are trademarks of NEWPORT Electronics, Inc.

**PATENT NOTICE:** This product is covered by one or more of the following patents: U.S. Pat. No. Des. 336,895; 5,274,577; 6,243,021 / Canada 2052599; 2052600 / Italy 1249456; 1250938 / France Brevet No. 91 12756 / Spain 2039150; 2048066 / UK Patent No. GB2 249 837; GB2 248 954 / Germany DE 41 34398 C2. Other International Patents Pending.



This device is marked with the international caution symbol. It is important to read the Setup Guide before installing or commissioning this device as it contains important information relating to safety and EMC.

# PREFACE

## Manual Objectives

This manual shows you how to set up and use the Differential Temperature Meter with Thermocouple.

### Standard Procedures:

- Checking voltage jumpers, or changing voltage power
- Mounting the panel
- Selecting the input type
- Selecting a decimal point position
- Selecting reading configuration (Fahrenheit or Celsius)
- Setting setpoint configurations
- Setting setpoint deadbands
- Entering cold junction offset
- Matching input 1 thermocouple with respect to input 2
- Selecting meter display

### Analog Output Procedures:

- Enabling/disabling analog output
- Selecting analog output as current or voltage
- Selecting analog output or proportional control
- Routing analog output
- Selecting proportional band
- Using manual reset (offsetting setpoint errors)
- Scaling analog output
- Accessing the deviation mode
- Tuning the proportional controller

Table A-1. Sections of the Manual

| <b>If you want to read about:</b>   |          | <b>Refer to section</b>                    |
|---|----------|--|
| Unpacking and safety considerations   | 1        | Introduction                               |
| Meter description and features  | 2        | About the Meter                            |
| Main board power jumpers; panel mounting, sensor input, main power and analog and relay output  | 3        | Getting Started                            |
| Procedures for: Input type; decimal point position; reading configuration: setpoint configurations; setpoint deadbands, output configuration (analog output); analog output routing; proportional band; manual reset, analog output scaling, cold junction offset | 4        | Configuring the Meter                      |
| The deviation mode  | 5        | Accessing the Deviation Mode               |
| The match mode  | 6        | Using the Match Mode                       |
| The two types of display reading modes  | 7        | Selecting Meter Display modes              |
| Proportional controller tuning  | 8        | Tuning the Proportional Controller         |
| Display messages  | 9        | Display Messages                           |
| Meter menu/submenu messages   | 10<br>11 | Menu Configuration<br>Front Panel Displays |
| Setpoint configuration messages   | 12       | Setpoint Configuration Displays            |
| Specifications  | 13       | Specifications                             |

## NOTES, WARNINGS and CAUTIONS

Information that is especially important to note is identified by three labels:

- \* **NOTE**
- \* **WARNING**
- \* **CAUTION**



**NOTE:** provides you with information that is important to successfully setup and use the meter.



**CAUTION:** tells you of circumstances or practices that can affect the timer's functionality.



**WARNING:** tells you of circumstances or practices that can lead to personal injury as well as damage to equipment.

# Table of Contents

| Section   | Page |
|---|------|
| <b>SEC 1 INTRODUCTION</b> .....                             | 1    |
| 1.1 Unpacking .....   | 1    |
| 1.2 Safety Considerations .....                             | 2    |
| <b>SEC 2 ABOUT THE METER</b> .....                          | 3    |
| 2.1 Description .....                                       | 3    |
| 2.2 Features .....  | 3    |
| 2.3 Available Accessories and Add-ons.....                  | 4    |
| 2.4 Front of the Meter.....                                 | 5    |
| 2.5 Back of the Meter .....                                 | 9    |
| 2.6 Disassembly .....                                       | 11   |
| <b>SEC 3 GETTING STARTED</b> .....                          | 12   |
| 3.1 Rating/Product Label.....                               | 12   |
| 3.2 Main Board Power Jumpers.....                           | 13   |
| 3.3 Panel Mounting .....                                    | 15   |
| 3.4 Connecting Sensor Input.....                            | 16   |
| 3.5 Connecting Main Power .....                             | 17   |
| 3.6 Connecting Analog and Relay Output.....                 | 18   |
| <b>SEC 4 CONFIGURING THE METER</b> .....                    | 20   |
| 4.1 Selecting the Input Type .....                          | 20   |
| 4.2 Selecting a Decimal Point Position .....                | 21   |
| 4.3 Selecting Reading Configuration .....                   | 22   |
| 4.4 Setting Setpoint 1 Configurations .....                 | 23   |
| 4.5 Setting Setpoint 2 Configurations .....                 | 24   |
| 4.6 Setting the Setpoint 1 Deadband .....                   | 25   |
| 4.7 Setting the Setpoint 2 Deadband .....                   | 26   |
| 4.8 Selecting Output Configuration .....                    | 26   |
| 4.8.1 To Enable or Disable the Analog Output .....          | 27   |
| 4.8.2 To Select Analog Output as Current or Voltage.....    | 27   |
| 4.8.3 To Select Analog Output or Proportional Control ..... | 27   |
| 4.9 Routing Analog Output.....                              | 28   |
| 4.10 Selecting Proportional Band.....                       | 29   |
| 4.11 Using Manual Reset.....                                | 30   |
| 4.12 Scaling the Analog Output .....                        | 31   |
| 4.13 Entering Cold Junction Offset .....                    | 34   |
| <b>SEC 5 ACCESSING THE DEVIATION MODE</b> .....             | 35   |
| <b>SEC 6 MATCHING TWO INPUTS</b> .....                      | 36   |
| <b>SEC 7 SELECTING METER DISPLAY</b> .....                  | 38   |

# Table of Contents

| Section                                       | Page |
|---|------|
| SEC 8 TUNING THE PROPORTIONAL CONTROLLER..... | 39   |
| SEC 9 DISPLAY MESSAGES .....                  | 40   |
| SEC 10 MENU CONFIGURATION .....               | 41   |
| SEC 11 FRONT PANEL DISPLAYS.....              | 43   |
| SEC 12 SETPOINT CONFIGURATIONS DISPLAYS ..... | 46   |
| SEC 13 SPECIFICATIONS .....                   | 47   |
| SEC 14 FACTORY PRESET VALUES.....             | 51   |
| CE APPROVAL INFORMATION .....                 | 52   |

## List of Figures

|   |    |
|---|----|
| 2-1 Front-Panel .....                               | 5  |
| 2-2 Connector Label (AC Power with DC detail) ..... | 9  |
| 3-1 Main Board Power Jumpers (W1, W2, W3) .....     | 13 |
| 3-2 Main Board Jumper Positions.....                | 13 |
| 3-3 Meter - Exploded View .....                     | 15 |
| 3-4 Panel Cut-out.....                              | 15 |
| 3-5 Sensor Input Connection .....                   | 16 |
| 3-6 Main Power Connections - AC .....               | 17 |
| 3-7 Main Power Connections - DC .....               | 18 |
| 3-8 Analog Output Connections.....                  | 18 |
| 3-9 Relay Output Connections.....                   | 19 |
| 3-10 Isolated Analog Output Connections .....       | 19 |
| 4-1 Proportional Control.....                       | 29 |
| 13-1 Meter Dimensions.....                          | 50 |

## List of Tables

|  |    |
|--|----|
| A-1 Sections of the Manual.....            | ii |
| 2-1 Accessories and Add-ons.....           | 4  |
| 2-2 Connector Description .....            | 10 |
| 3-1 S3 Jumper Functions.....               | 14 |
| 3-2 AC Power Connections .....             | 17 |
| 7-1 Truth Table for Display Values .....   | 38 |
| 9-1 Display Messages .....                 | 40 |
| 10-1 Configuration Menu .....              | 41 |
| 11-1 Front Panel Displays .....            | 43 |
| 11-2 "RUN" Mode Displays.....              | 45 |
| 12-1 Setpoint Configuration Displays ..... | 46 |
| 14-1 Factory Preset Values .....           | 51 |





# SECTION 1. INTRODUCTION

## 1.1 UNPACKING

Remove the Packing List and verify that all equipment has been received. If there are any questions about the shipment, use the phone numbers listed on the back cover to contact the Customer Service Department nearest you. Upon receipt of shipment, inspect the container and equipment for any signs of damage. Take particular note of any evidence of rough handling in transit. Immediately report any damage to the shipping agent.



*The carrier will not honor any claims unless all shipping material is saved for their examination. After examining and removing contents, save packing material and carton in the event reshipment is necessary.*

Verify that you receive the following items in the shipping box:

| <b>QTY</b> | <b>DESCRIPTION</b>   |
|------------|--|
| 1          | Differential THERMOCOUPLE Meter with all applicable connectors attached. |
| 1          | Owner's Manual   |
| 1          | Set Mounting brackets  |
| 1          | QuickStart Manual  |



*If you ordered any of the available options (except the "BL" Blank Lens option), they will be shipped in a separate container to avoid any damage to your indicator/controller.*

## 1.2 SAFETY CONSIDERATIONS

---



This device is marked with the **international caution symbol**. It is **important to read** this manual before installing or commissioning this device as it contains important information relating to **Safety and EMC** (Electromagnetic Compatibility).

---

This instrument is a **panel mount** device protected in accordance with EN 61010-1:2001, electrical safety requirements for electrical equipment for measurement, control and laboratory. Installation of this instrument should be done by qualified personnel. In order to ensure safe operation, the following instructions should be followed.



This instrument has **no power-on switch**. An external **switch or circuit-breaker** shall be included in the building installation as a disconnecting device. It shall be marked to indicate this function, and it shall be in close proximity to the equipment within easy reach of the operator. The switch or circuit-breaker shall not interrupt the Protective Conductor (Earth wire), and it shall meet the relevant requirements of IEC 947-1 and IEC 947-3 (International Electrotechnical Commission). The switch shall not be incorporated in the main supply cord.

Furthermore, to provide protection against **excessive energy** being drawn from the main supply in case of a fault in the equipment, an **overcurrent** protection device shall be installed.



- Do not exceed voltage rating on the label located on the top of the instrument housing.
- Always disconnect power before changing signal and power connections.
- Do not use this instrument on a work bench without its case for safety reasons.
- Do not operate this instrument in flammable or explosive atmospheres.
- Do not expose this instrument to rain or moisture.
- Unit mounting should allow for adequate ventilation to ensure instrument does not exceed operating temperature rating.
- Use electrical wires with adequate size to handle mechanical strain and power requirements. Install without exposing bare wire outside the connector to minimize electrical shock hazards.

### EMC Considerations

- Whenever EMC is an issue, always use shielded cables.
- Never run signal and power wires in the same conduit.
- Use signal wire connections with twisted-pair cables.
- Install Ferrite Bead(s) on signal wires close to the instrument if EMC problems persist.

**Failure to follow all instructions and warnings may result in injury!**

## SECTION 2. ABOUT THE METER

### 2.1 DESCRIPTION

The Differential Temperature meter with thermocouple is a value packed indicator/ controller. Four full digits allow for an accurate display of your temperature. Select from J, K, T or DIN J thermocouple types. Your meter may be a basic indicator or it may include analog output or dual relay output. Analog or dual relay output must be ordered at time of purchase. Analog output is fully scalable and may be configured as a proportional controller, or to follow your display. Dual 5 amp, form C relays control critical processes. Front panel peak detection and memory is also standard.

### 2.2 STANDARD FEATURES

The following is a list of features:

- \* 4-digit, red, 14 segment LED Display
- \* NEMA 4/Type 4 Front Bezel
- \*  $\pm 0.5$  °C accuracy
- \* Cross channel isolation up to  $\pm 5V$
- \* Match Capability
- \* Automatic Decimal Adjustment
- \* Non-volatile memory-no battery backup
- \* 115 or 230 Vac 50/60 Hz power supply or  
10-32 Vdc or 26-56 Vdc
- \* T1, T2, T1-T2 display

### OPTIONAL FEATURES

- \* Dual 5 amp, form C relay outputs
- \* Scalable analog output
- \* Analog out proportional control
- \* Front-panel deviation correction
- \* Easy setup for proportional control

## 2.3 AVAILABLE ACCESSORIES

Table 2-1. Accessories and Add-ons

| <b>MODEL NO.</b> | <b>DESCRIPTION</b>  |
|------------------|---|
| FS               | Special Calib/Config  |
| SPC4             | NEMA-4 Splash Proof Cover   |
| SPC18            | NEMA-4 Splash Proof Cover, NEW  |
| TP1A             | Trimplate panel adaptor. Adapts DIN1A/DIN2A cases to larger panel cut-outs. |
| RP18             | 19-In. Rack panel for one (1) 1/8 DIN instrument                            |
| RP28             | 19-In. Rack panel for two (2) 1/8 DIN instrument                            |
| RP38             | 19-In. Rack panel for three (3) 1/8 DIN instrument                          |

## 2.4 FRONT OF THE METER

Figure 5-1 shows the location of each part of the front of the meter.

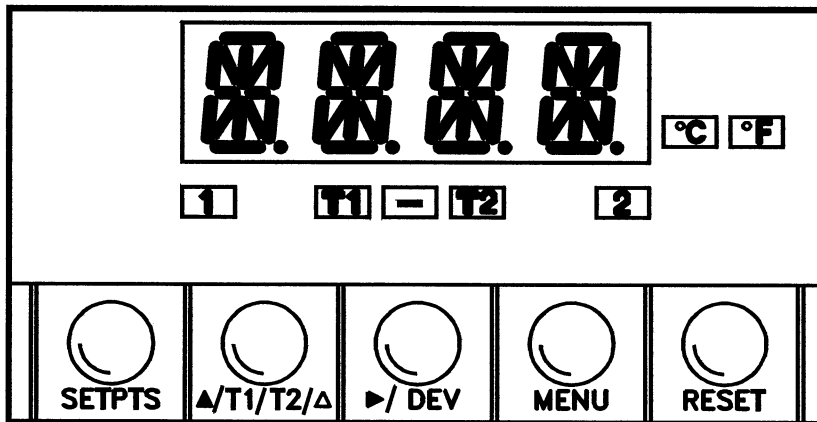

Figure 2-1. Front-Panel

### **METER DISPLAY:**

**Digital LED display** - 1.9.9.9. or 9.9.9.9. 4-digit 14 segment, 0.54" high LED display with programmable decimal point.

These meter display windows light when appropriate:

|         |                          |
|---------|--------------------------|
| °C      | Display is in celsius    |
| °F      | Display is in fahrenheit |
| 1       | Setpoint 1 status        |
| 2       | Setpoint 2 status        |
| T1      | T1 on display            |
| T2      | T2 on display            |
| T1 - T2 | T1 - T2 on display       |

## 2.4 FRONT OF THE METER (Continued)

### **METER BUTTONS**

#### **SETPTS BUTTON**

In the "RUN" mode, this button will sequentially recall the previous setpoint settings. As necessary, use the ▲/T1/T2▲ and >/DEV buttons to alter these settings, then press the **SETPTS** button to store new values.

Unless you press the **SETPTS**, > **DEV**, or ▲/T1/T2▲ button within 20 seconds the meter will scroll to setpoint 2 and then to the "RUN" mode.

---

#### **▲/T1/T2▲ BUTTON**

In the "RUN" mode, this button will scroll to display T1, T2 and T1 - T2.

In the configuration mode, press this button to change the values of the flashing digit shown on the display and/or toggle between menu choices, such as **R.1=F** or **R.1=C**. When configuring your setpoint values, press the ▲/T1/T2▲ button to advance the flashing digit's value from 0 to 9 by 1.

---

#### **>/DEV BUTTON**

In the "RUN" mode press the >/DEV button to:

- Display the deviation with reading for **setpoint 1** if **R.2=D** on "**RD.CF**" (refer to Section 4.3 - Reading Configuration).
- Return to the match mode if **R.2=M** in "**RD.CF**" (for detail on match mode, refer to Section 6 - Match Mode).

In the configuration mode, press this button to scroll to the next digit.

---

## 2.4 FRONT OF THE METER (Continued)

### MENU BUTTON

Press the **MENU** button to terminate the current measuring process and enter you into the configuration mode.

In the configuration mode, press the **MENU** button to store changes in the non-volatile memory and then advance you to the next menu item. To lock the **MENU** button, **install S3E jumper**. Refer to Table 3-1 for more information about the S3 jumpers.

---

### RESET BUTTON

In the "**RUN**" mode, press the **RESET** button to:

- To reset the latched setpoints in the "**RUN**" mode. The meter will display "**SP.RS**".
- To reset the match value in the match mode. The meter will display "**MV.RS**".
- To perform tuning for Proportional Control if meter is in the Deviation mode and **0.3=P** (refer to Section 8 - Tuning the Proportional Controller). The meter will display "**TUNE**".

In the configuration mode, press the **RESET** button once to review the previous menu. Press the **RESET** button twice to result in a hard reset and return you to the "**RUN**" mode.

---

## 2.4 FRONT OF THE METER (Continued)

### ***RESET, MENU and SETPTS Button Lock Out***

To lock the **RESET**, **MENU** and **SETPTS** buttons, follow these steps:

In the run mode -

1. Press and hold down the **RESET** button. The meter shows "**SP.RS**". Do not release the **RESET** button.
2. Press the **MENU** button and hold the **RESET** button down (3 - 5 seconds) until the meter shows "**LOCK**".
3. Release both buttons.

To unlock the **RESET**, **MENU** and **SETPTS** buttons, follow these steps:

1. Press and hold down the **RESET** button. The meter shows "**LOCK**". Do not release the **RESET** button.
2. Press the **MENU** button and hold the **RESET** button down (3 - 5 seconds) until the meter shows "**UN.LK**".
3. Release both buttons.



*The above procedures do not affect the functionality of the S3-A and S3-E jumpers. The S3-A jumper enable/disables all front-panel buttons. The S3-E jumper enables/disables the MENU button.*



## 2.5 BACK OF THE METER

Figure 2-2 shows the connector label mounted at the top of the meter housing. Table 2-2 gives a brief description of each connector at the back of the meter.

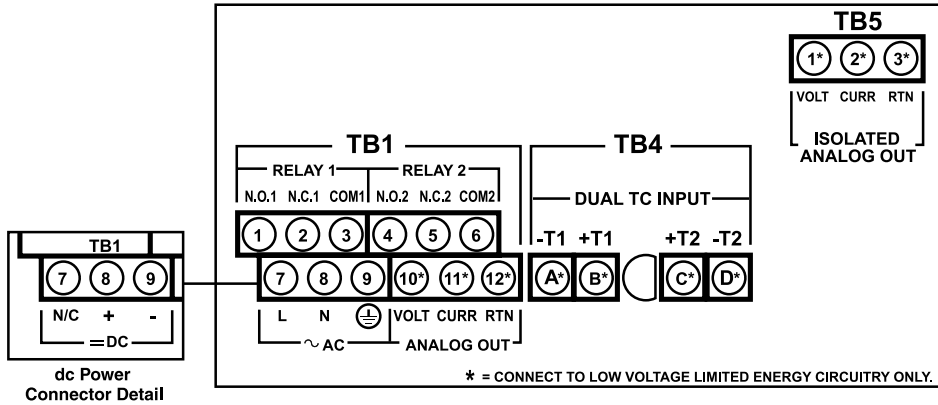

Figure 2-2 Connector Label (ac power with dc detail)

## 2.5 BACK OF THE METER (Continued)

Table 2-2. Connector Description

| CONNECTOR | DESCRIPTION  |
|-----------|--|
| TB1-1     | Setpoint 1: Normally open ( <b>N.O.1</b> ) connection.   |
| TB1-2     | Setpoint 1: Normally closed ( <b>N.C.1</b> ) connection. |
| TB1-3     | Setpoint 1: Common 1 ( <b>COM1</b> ) connection          |
| TB1-4     | Setpoint 2: Normally open ( <b>N.O.2</b> ) connection.   |
| TB1-5     | Setpoint 2: Normally closed ( <b>N.C.2</b> ) connection. |
| TB1-6     | Setpoint 2: Common 2 ( <b>COM2</b> ) connection          |
| TB1-7     | AC Line connection (No connection on DC powered units)   |
| TB1-8     | AC Neutral connection<br>(+ Input on DC powered units)   |
| TB1-9     | AC Earth Ground<br>(DC power return on DC powered units) |
| TB1-10    | Analog 1 voltage output                                  |
| TB1-11    | Analog 2 current output                                  |
| TB1-12    | Analog 3 return  |
| TB4-A     | -TC input #1 (-T1)                                       |
| TB4-B     | +TC input #1 (+T1)                                       |
| TB4-C     | +TC input #2 (+T2)                                       |
| TB4-D     | -TC input #2 (-T2)                                       |

## 2.6 DISASSEMBLY

You may need to open up the meter for one of the following reasons:

- To check or change the 115 or 230 V ac power jumpers.
- To install or remove jumpers on the main board.



*Disconnect the power supply before proceeding.*

To remove and access the main board, follow these steps:

1. Disconnect the main power from the meter.
2. Remove the back case cover.
3. Lift the back of the main board upwards and slide out of the case.



**CAUTION:** The meter has no power-on switch, so it will be in operation as soon as you apply power.

---

If you power off/on the meter, or perform a hard reset (press the RESET button twice) the meter shows “RST”, followed by “TC”.

## SECTION 3. GETTING STARTED



**CAUTION:** The meter has no power-on switch, so it will be in operation as soon as power is applied.

### 3.1 RATING/PRODUCT LABEL

This label is located on top of the meter housing.

### 3.2 MAIN BOARD POWER JUMPERS (refer to Figures 3-1 & 3-2)



**IMPORTANT:** If you want to change the Factory preset jumpers, do the following steps; otherwise go to Section 3-3.



*Disconnect the power from the unit before proceeding.*

To check voltage jumpers, or to change from 115 V to 230 V ac:

1. Remove the main board from the case. Refer to Section 2.6.
2. Locate the solder jumpers W1, W2, and W3 (located near the edge of the main board alongside the transformer - refer to Figure 3-1).
3. If your power requirement is **115 V ac**, install solder jumpers **W1 and W3**, but do not install jumper **W2**.

If your power requirement is **230 V ac**, install solder jumper **W2**, but do not install jumpers **W1 or W3**.

### 3.2 MAIN BOARD POWER JUMPERS (Continued)

Figure 3-1 shows the location of solder jumpers W1, W2 and W3.

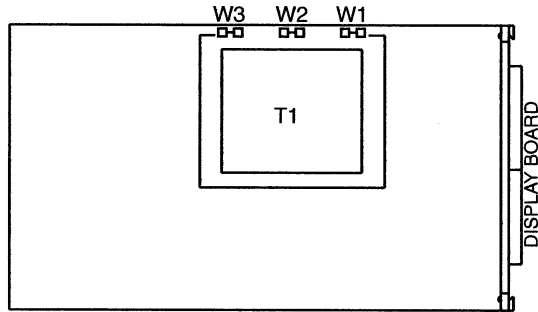

Figure 3-1. Main Board Jumpers (W1, W2, W3)

Figure 3-2 shows the TB4 cover and the location of jumper positions on the main board.

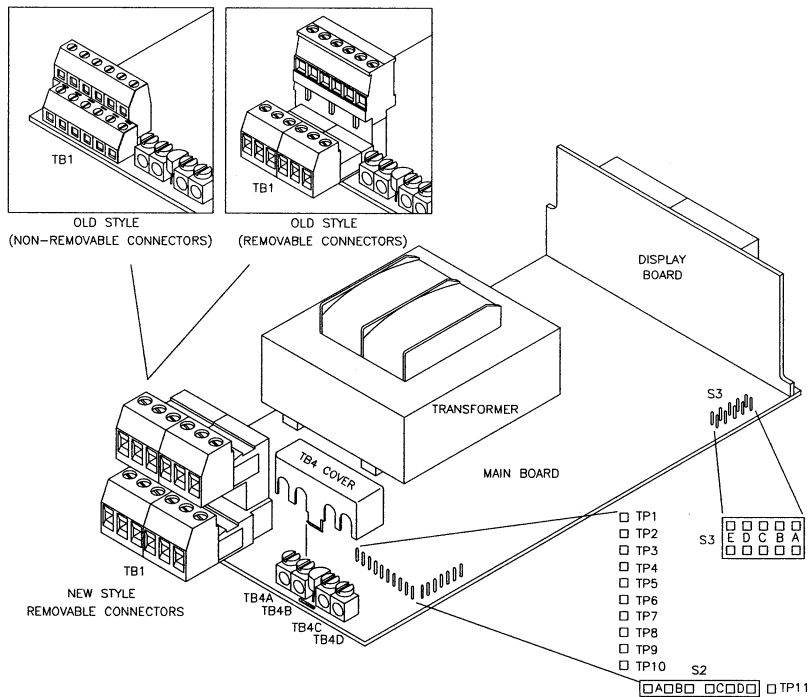

Figure 3-2. Main Board Jumper Positions

## 3.2 MAIN BOARD POWER JUMPERS (Continued)

S2 jumpers are for sensor break indications (refer to Figure 3-2):

- S2A jumper is for negative sensor break on input 1 (i.e. refrigeration)
- S2B jumper is for positive sensor break on input 1 (i.e. heating)
- S2C jumper is for positive sensor break on input 2 (i.e. heating)
- S2D jumper is for negative sensor break on input 2 (i.e. refrigeration)

S3 jumpers are used for the following (refer to Figure 3-2):

- To enable or disable the front panel push-buttons
- To allow for an extremely low resistance load for analog output
- To disable the MENU button
- To perform calibration procedure

Test pins TP1 - TP10 are for testing purposes. Do not use these pins as reading errors may result.

Table 3-1. S3 Jumper Functions

| JUMPER | DESCRIPTION   |
|--------|---|
| S3-A   | Install to enable front panel push-buttons. Remove to disable all front panel push-buttons  |
| S3-B   | Removed. Install for meter calibration.   |
| S3-C   | Normally removed. Install for analog voltage output when load has less than 1 K $\Omega$ impedance. Care should be taken when installing this jumper.   |
| S3-D   | Removed. Not used.  |
| S3-E   | If installed without S3-B, the <b>MENU</b> button locks out (while in the <b>"RUN"</b> mode, pressing the <b>MENU</b> button results in the display showing <b>"LOCK"</b> and then returns to the <b>"RUN"</b> mode). |

**Note: S4 jumper is not used.**

### 3.3 PANEL MOUNTING

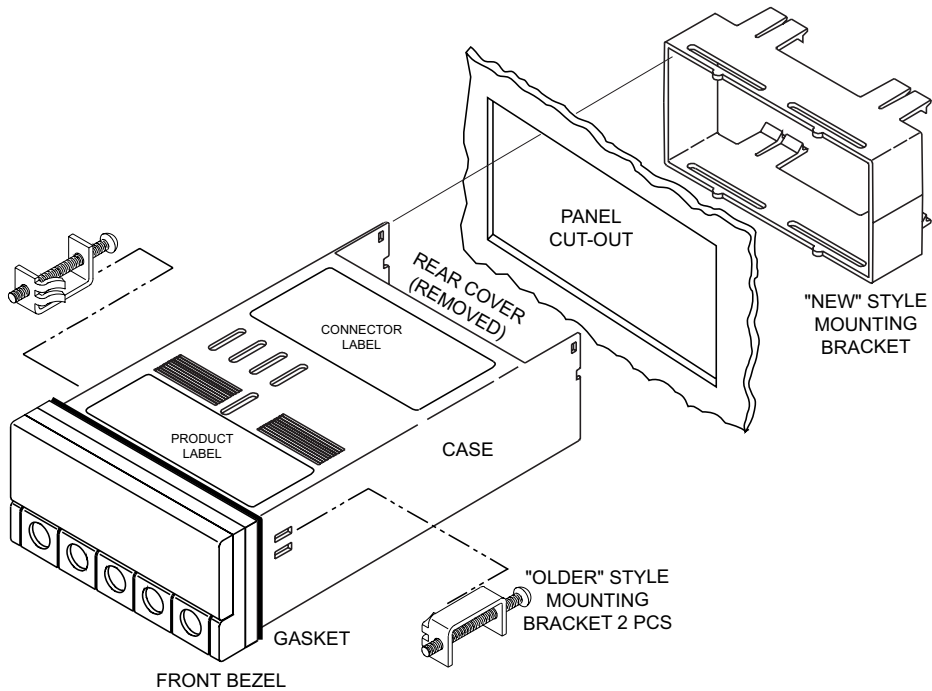

Figure 3-3 Meter - Exploded View

1. Cut a hole in your panel, as shown in Figure 3-3. For specific dimensions refer to Figure 3-4.
2. Insert the meter into the hole. Be sure the front bezel gasket is flush to the panel.
3. Slide on mounting bracket to secure.
4. Proceed to Section 3.4 to connect your sensor input and main power.

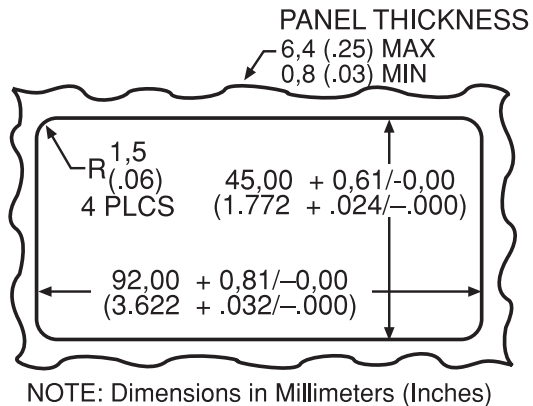

Figure 3-4 Panel Cut-Out

### 3.4 CONNECTING SENSOR INPUT

Connect the thermocouple sensors as shown in Figure 3-5.

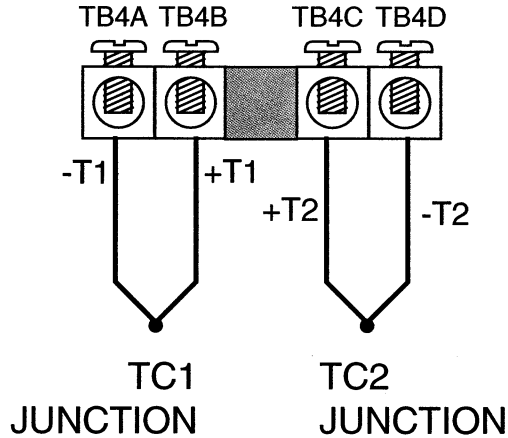

Figure 3-5. Sensor Input Connection



*Install plastic cover after thermocouple connection.*



**CAUTION:** For proper operation when only one thermocouple sensor is used, you must add jumper wire across the unused input connector. This jumper will cause the meter to read approximately the temperature at the connector.



### 3.5 CONNECTING MAIN POWER

Figure 3-6 shows the proper AC power main power connections.

**WARNING:** Do not connect AC power to your meter until you have completed all input and output connections. Failure to do so may result in injury!

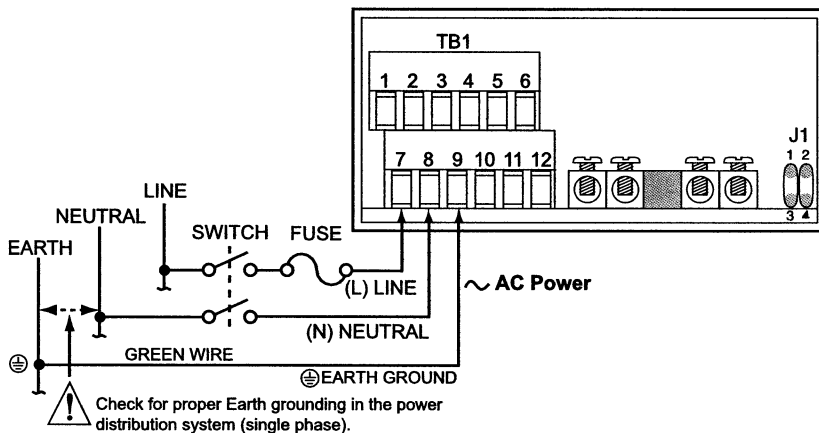

Figure 3-6. Main Power Connections - AC

Table 3-2 shows the wire color and respective terminal connections for both USA and Europe.

Table 3-2. AC Power Connections

| TB1 | AC POWER     | WIRE COLORS  |       |
|-----|--------------|--------------|-------|
|     |              | EUROPE       | USA   |
| 7   | ~ ac Line    | Brown        | Black |
| 8   | ~ ac Neutral | Blue         | White |
| 9   | ~ac Earth    | Green/Yellow | Green |

### 3.5 CONNECTING MAIN POWER (Continued)

Connect the DC main power connections as shown in Figure 3-7.

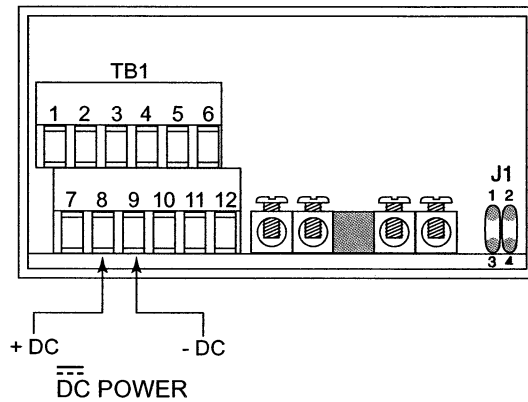

Figure 3-7. Main Power Connections - DC

### 3.6 CONNECTING ANALOG AND RELAY OUTPUT

If you have purchased a meter with analog or dual relay output, refer to the following figures for output connections.

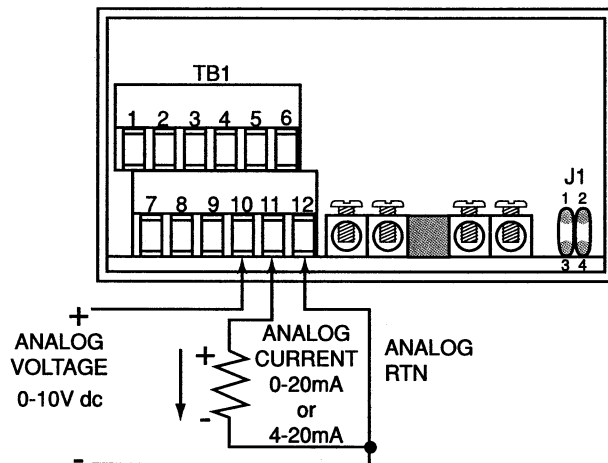

Figure 3-8. Analog Output Connections

### 3.6 CONNECTING ANALOG AND RELAY OUTPUT (Continued)

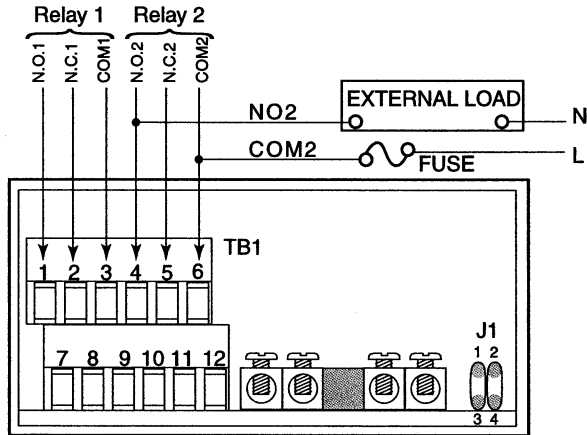

Figure 3-9. Relay Output Connections

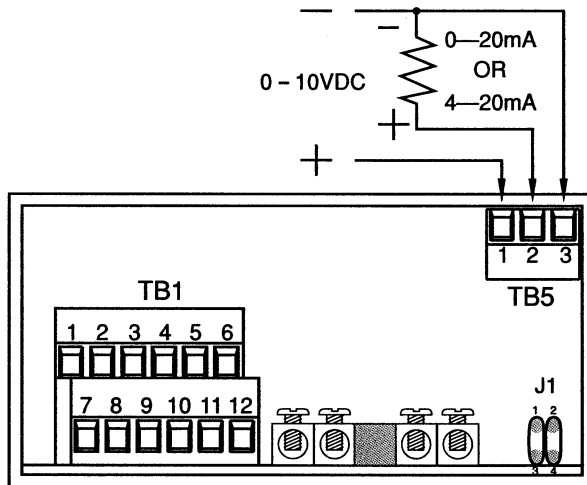

Figure 3-10. Isolated Analog Output Connections

## SECTION 4. CONFIGURING THE METER

Refer to Table 10-1 for a summary list of menu configurations.

### 4.1 SELECTING THE INPUT TYPE (INPT)

To select your appropriate thermocouple input type signal:

1. Press the **MENU** button. "**INPT**" appears.
2. Press the **➤/DEV** button. One of the following input types flash (**K.TC** is the factory default):
  - \* **J.TC** - Iron vs. Constantan (NIST)
  - \* **K.TC** - Nickel-Chromium vs. Nickel-Aluminum (NIST)
  - \* **T.TC** - Copper vs. Copper Nickel (NIST)
  - \* **DJ.TC** - Iron vs. Copper (DIN)
3. Press the **▲/T1/T2▲** button to scroll through available choices.
4. Press the **MENU** button to store your choice. The meter momentarily shows "**STRD**", followed by "**DEC.P**" (Decimal point).



*Anytime you change the thermocouple type, calibrate for cold junction compensation offset (refer to Section 4.13). Factory default setting is K.TC thermocouple.*

## 4.2 SELECTING A DECIMAL POINT POSITION (DEC.P)

To select a decimal point display position:

1. Press the **MENU** button until the meter shows "**DEC.P**".
2. Press the **➤/DEV** button. The meter shows one of the following:
  - **FFFF.**
  - **FFF.F**
3. Press the **▲/T1/T2▲** button to scroll between available choices.
4. Press the **MENU** button to store your choice. The meter momentarily shows "**STRD**", followed by "**RD.CF**" (Reading Configuration).



*When you change the decimal position the meter adjusts setpoints, deadbands, proportional band, and manual reset values. These adjustments are made according to the new decimal point. If one or more of these values overflows, the meter flashes "ER2" when you store new decimal point position value.*

### 4.3 SELECTING READING CONFIGURATION (RD.CF)

To select if your meter shows in °F (Fahrenheit) or °C (Celsius):

1. Press the **MENU** button until the meter shows "**RD.CF**".
2. Press the **➤/DEV** button. The meter shows one of the following:
  - **R.1=F** (°F)
  - **R.1=C** (°C)
3. Press the **▲/T1/T2▲** button to toggle between available choices.
4. Press the **➤/DEV** button. The meter shows one of the following:
  - **R.2=D** (**➤/DEV** button shows deviation in the "**RUN**" mode - refer to Section 5)
  - **R.2=M** (**➤/DEV** button takes the meter to the match mode -refer to Section 6)
5. Press the **MENU** button to store your selection(s). The meter momentarily shows "**STRD**", followed by "**S1.CF**" (Setpoint 1 Configuration).

#### 4.4 SETTING SETPOINT 1 CONFIGURATIONS (S1.CF)

Setpoint 1 is not active unless your meter has dual relay output capabilities. The LED's will display whether the (**S1.CF**) is active or not.

You may use Setpoint 1 Configuration ("**S1.CF**") for the following:

- To set the setpoint's active band above or below your chosen value
  - To select whether the setpoint operation is latched or unlatched
  - To assign setpoint 1 to T1, T2 or T1 - T2
1. Press the **MENU** button until the meter shows "**S1.CF**".
  2. Press the **➤/DEV** button. The meter shows one of the following:
    - **S.1=A** (Active above the setpoint)
    - **S.1=B** (Active below the setpoint)
  3. Press the **▲/T1/T2▲** button to toggle between available choices.
  4. Press the **➤/DEV** button again. The meter shows one of the following:
    - **S.2=L** (Setpoint 1 latched)
    - **S.2=U** (Setpoint 1 unlatched)
  5. Press the **▲/T1/T2▲** button to toggle between available choices.
  6. Press the **➤/DEV** button. The meter shows one of the following:
    - **S.3=0** (Setpoint 1 assigned to T1 - T2)
    - **S.3=1** (Setpoint 1 assigned to T1)
    - **S.3=2** (Setpoint 1 assigned to T2)
  7. Press the **▲/T1/T2▲** button to scroll among the available choices.
  8. Press the **MENU** button to store your choice(s). The meter momentarily shows "**STRD**", followed by "**S2.CF**" (Setpoint 2 Configuration).

## 4.5 SETTING SETPOINT 2 CONFIGURATIONS (S2.CF)

Setpoint 2 is not active unless your meter has dual relay output capabilities. The LED's will display whether the (**S2.CF**) is active or not. You may use Setpoint 2 Configuration ("**S2.CF**") for the following:

- To set the setpoint's active band above or below your chosen value
  - To select whether the setpoint operation is latched or unlatched
  - To assign setpoint 2 to T1, T2 or T1 - T2
1. Press the **MENU** button until the meter shows "**S2.CF**".
  2. Press the **➤/DEV** button. The meter shows one of the following:
    - **S.1=A (Active above the setpoint)**
    - **S.1=B** (Active below the setpoint)
  3. Press the **▲/T1/T2▲** button to toggle between available choices.
  4. Press the **➤/DEV** button again. The meter shows one of the following:
    - **S.2=L (Setpoint 1 latched)**
    - **S.2=U** (Setpoint 1 unlatched)
  5. Press the **▲/T1/T2▲** button to toggle between available choices.
  6. Press the **➤/DEV** button. The meter shows one of the following:
    - **S.3=0 (Setpoint 2 assigned to T1 - T2)**
    - **S.3=1** (Setpoint 2 assigned to T1)
    - **S.3=2** (Setpoint 2 assigned to T2)
  7. Press the **▲/T1/T2▲** button to scroll among the available choices.
  8. Press the **MENU** button to store your selection(s). The meter momentarily shows "**STRD**", followed by "**S1.DB**" (Setpoint 1 Deadband).



#### 4.6 SETTING THE SETPOINT 1 DEADBAND (S1.DB)

Setpoint 1 Deadband is not active unless your meter has dual relay output capabilities. The LED's will display whether the **(S1.DB)** is active or not.

To set the deadband (hysteresis) of setpoint 1.

1. Press the **MENU** button until the meter shows "**S1.DB**".
2. Press the **➤/DEV** button. The meter shows the last previously stored 4-digit number (0000 through 9999) with flashing 4th digit.
3. Press the **▲/T1/T2▲** button to change the value of the flashing digit. If you continue to press the **▲/T1/T2▲** button, the flashing digit's value continues to change.
4. Press the **➤/DEV** button to scroll to the next digit.
5. Press the **MENU** button to store your selection. "**STRD**" momentarily shows, followed by "**S2.DB**" (Setpoint 2 Deadband)

#### 4.7 SETTING THE SETPOINT 2 DEADBAND (S2.DB)

Setpoint 2 Deadband is not active unless your meter has dual relay output capabilities. The LED's will display whether the (S2.DB) is active or not.

To set the deadband (hysteresis) of setpoint 2.

1. Press the **MENU** button until the meter shows "**S2.DB**".
2. Press the **➤/DEV** button. The meter shows the last previously stored 4-digit number (0000 through 9999) with flashing 4th digit.
3. Press the **▲/T1/T2▲** button to change the value of the flashing digit. If you continue to press the **▲/T1/T2▲** button, the flashing digit's value continues to change.
4. Press the **➤/DEV** button to scroll to the next digit.
5. Press the **MENU** button to store your selection. The meter momentarily shows "**STRD**", followed by cold junction offset if you have a standard meter or "**OT.CF**" (Output Configuration) if you have analog output capabilities.

#### 4.8 SELECTING OUTPUT CONFIGURATION (OT.CF)

Output configuration (OT.CF) is not active unless your meter has analog output capabilities. The menu will display whether the analog output is present or not.

Use Output Configuration ("**OT.CF**") to select the following:

- To enable or disable the analog output
- To determine if the analog output is current or voltage
- To determine if the analog output is proportional to the display
- or to the error (the difference between reading and setpoint value)

#### 4.8.1 To Enable or Disable the Analog Output

1. Press the **MENU** button until the meter shows "**OT.CF**".
2. Press the **➤/DEV** button. The meter shows one of the following:
  - **O.1=D (Analog output disabled)**
  - **O.1=E (Analog output enabled)**
2. Press the **▲/T1/T2▲** button to toggle between available choices.
4. Press the **➤/DEV** button to select analog output as current/voltage or press the **MENU** button to store your selection. The meter momentarily shows "**STRD**", followed by "**OT.SO**" (refer to Section 4.12), or "**P.BND**" (refer to Section 4.10 - Proportional Band).

#### 4.8.2 To Select Analog Output as Current or Voltage

1. Press the **➤/DEV** button. The meter shows one of the following:
  - **O.2=V (Analog output = voltage)**
  - **O.2=C (Analog output = current)**
2. Press the **▲/T1/T2▲** button to toggle between available choices.
3. Press the **➤/DEV** button to select analog signal output/proportional control or press the **MENU** button to store your choice(s). The meter momentarily shows "**STRD**", followed by "**OUT**".

#### 4.8.3 To Select Analog Output or Proportional Control

To determine if the meter is to transmit an analog signal out (equal to your display), or serve as a proportional controller:

1. Press the **➤/DEV** button. The meter shows one of the following:
  - **O.3=A (Analog output is a retransmission of temperature)**
  - **O.3=P (Analog output is proportional to the error = display - setpoint 1)**
2. Press the **▲/T1/T2▲** button to toggle between available choices.
- 3a. If you select **O.3=A**, press the **MENU** button to store your selections. The meter momentarily shows "**STRD**", followed by "**OUT**".

#### 4.8.3 To Select Analog Output or Proportional Control (Continued)

- 3b. If you select **O.3=P**, press the **➤/DEV** button. The meter shows one of the following:
  - **O.4=D (Proportional analog output is DIRECT ACTING)**
  - **O.4=R (Proportional analog output is REVERSE ACTING).**
4. Press the **▲/T1/T2▲** button to toggle between available choices.
5. Press the **MENU** button to store your selections. The meter momentarily shows "**STRD**", followed by "**OUT**".

Additionally, if you select **O.2=V** (Analog output to be voltage), press the **➤/DEV** button. The meter shows one of the following:

- **O.5=F (Proportional 0-10 V analog output)**
  - **O.5=H (Proportional 0-5 V analog output).**
6. Press the **▲/T1/T2▲** button to toggle between available choices.
  7. Press the **MENU** button to store your choices. The meter momentarily shows "**STRD**", followed by "**OUT**" (Analog Output Routing).

#### 4.9 ROUTING ANALOG OUTPUT (OUT)

Use Analog Output Routing (**OUT**) to choose which value (**T1**, **T2** or **T1 - T2**) to route to the Analog Output.

1. Press the **➤/DEV** button. The meter flashes one of the following (current setting):
  - **T1**
  - **T2**
  - **T1 - T2**
2. Press the **▲/T1/T2▲** button to scroll between available choices.
3. Press the **MENU** button to store your selection. The meter momentarily shows "**STRD**", followed by "**P.BND**" (Proportional Band if **0.3=P**) or "**OT.S.O**" (Output Scale and Offset if **0.3=A**).



**Selected item will also be considered for the deviation value (refer to Section 5 - Deviation Mode).**

#### 4.10 SELECTING PROPORTIONAL BAND (P.BND)

Proportional Band (**P.BND**) is not active unless your meter has analog output and relay capabilities. The menu will display whether analog output is present or not.

- A proportional controller's output is linearly proportional to the change of the error signal, whenever the signal is within 2 prescribed values (Proportional Band).
- There are three (3) points of interest on the proportional controller transfer curve.
- The first is the magnitude of the error signal that drives the controller to full on (e.g. 20 mA out for 4-20 mA).

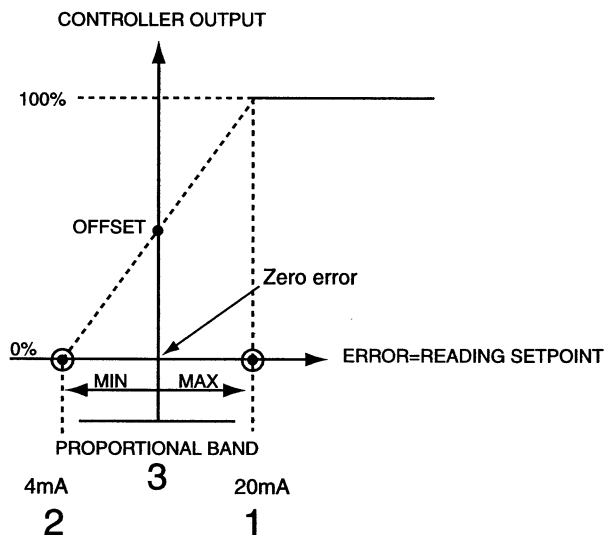

Figure 4-1. Proportional Band

- The second is the magnitude of the error signal that drives the controller output to "full off" (e.g. 4 mA out on 4-20 mA). These two (2) points need not be equally spaced on either side of the zero error point.
- The third is the factor that determines where these two (2) points fall. This factor is called the "Offset" and it is the output value of the controller, which causes zero error.

The above example illustrates the parameters for the 4-20mA analog out, likewise, analog voltage output will have these (3) points of interest.

## 4.10 SELECTING PROPORTIONAL BAND (P.BND) (Continued)

If **A** is the controller gain then,

$$\text{Proportional Band} = \frac{\text{Max. out} - \text{Min. out}}{A}$$

$$\text{CONTROLLER OUT} = A * \text{ERROR} + \text{OFFSET}$$

To select the proportional band for your proportional controller.

1. Press the **MENU** button until the meter shows "**P.BND**".
2. Press the **>/DEV** button. The meter shows the last previously stored 4-digit number (0000 through 9999) with flashing 4th digit.
3. Press the **▲/T1/T2▲** button to change the value of the flashing digit. If you continue to press the **▲/T1/T2▲** button, the flashing digit's value will continue to change.
4. Press the **>/DEV** button to scroll to the next digit.
5. Press the **MENU** button to store your selection. The meter momentarily shows "**STRD**", followed by "**M.RST**" (Manual Reset)



*The meter only shows "P.BND" only if you select analog output as proportional.*

## 4.11 USING MANUAL RESET (M.RST)

Manual Reset (M.RST) is not active unless your meter has analog output capabilities. The menu will display whether the analog output is present or not.

This feature allows you to offset the error that may occur within your setpoint. To determine the amount of error, you must compare your display value to the setpoint 1 value. The difference between these two values will be the amount of error that you may want to enter into Manual Reset (**M.RST**).

#### 4.11 USING MANUAL RESET (M.RST) (Continued)

1. Press the **MENU** button until the meter shows "**M.RST**".
2. Press the **➤/DEV** button. The meter shows last previously stored 4-digit number (-1999 through 9999) with flashing 4th digit.
3. Press the **▲/T1/T2▲** button to change the value of the flashing digit. If you continue to press the **▲/T1/T2▲** button, the flashing digit's value continues to change.
4. Press the **➤/DEV** button to scroll to the next digit.
5. Press the **MENU** button to store your selection. The meter momentarily shows "**STRD**", followed also momentarily by "**RST**" (Reset). The meter then shows "**CJ.OF**" (Cold Junction Offset) (refer to Section 4.13).



***The meter only shows "M.RST" if you select analog output as proportional.***

#### 4.12 SCALING THE ANALOG OUTPUT (OUTPUT SCALE AND OFFSET - OT.S.O)

Output Scale and Offset (**OT.S.O**) is not active unless your meter has analog output capabilities. The menu will display whether the analog output is present or not. Output Scale and Offset scales the analog output to be equal to the meter's display and/or any engineering units you require. You may scale the output for direct (4-20 mA, 0-10 V, etc) or reverse acting (20-4 mA, 10-0 V, etc).



***The meter only shows "OT.S.O" if you select analog output as a retransmission of temperature.***

1. Press the **MENU** button until the meter shows "**OT.S.O**".
2. Press the **➤/DEV** button. The meter shows "**RD 1**" (Read 1).

*Note: This is your first point of display reading.*

#### 4.12 SCALING THE ANALOG OUTPUT (OUTPUT SCALE AND OFFSET - OT.S.O) (Continued)

3. Press the **>/DEV** button again. The meter shows the last previously stored 4-digit number (-1999 through 9999) with flashing 4th digit.
4. Press the **▲/T1/T2▲** button to change the value of Read 1.
5. Press the **>/DEV** button to scroll to the next digit.
6. Press the **MENU** button to store your selection. The meter shows "OUT.1" (Output 1).



***This starting analog signal corresponds to your Read 1 display.***

7. Press the **>/DEV** button. The meter shows the selected output.



***If you select "O.2=V" for voltage, the maximum signal you may select is 10.00 for a 0-10 V dc signal output. If you select "O.2=C" for current, the maximum signal you may select is 20.00 for a 0-20 or 4-20 mA dc signal output.***

8. Press the **▲/T1/T2▲** button to enter the output 1 signal selection. If you continue to press the **▲/T1/T2▲** button, the flashing digit's value continues to change.
9. Press the **>/DEV** button to scroll to the next digit.
10. Press the **MENU** button to store your selection. The meter shows "RD 2" (Read 2).

**Note: This is your second point of display reading.**

11. Press the **>/DEV** button. The last previously stored 4-digit number (-1999 through 9999) shows with flashing 4th digit.



## 4.12 SCALING THE ANALOG OUTPUT (OUTPUT SCALE AND OFFSET - OT.S.O) (Continued)

12. Press the **▲/T1/T2▲** button to change the value of the flashing digit. If you continue to press the **▲/T1/T2▲** button, the flashing digit's value continues to change.
13. Press the **➤/DEV** button to scroll to the next digit.
14. Press the **MENU** button to store your selection. The meter shows **"OUT.2"** (Output 2).



*This analog signal should correspond to your Read 2 display.*

15. Press the **➤/DEV** button. The meter shows the selected output.



*If you select "O.2=V" for voltage, the maximum signal you may select is 10.00 for a 0-10 V dc signal output. If you select "O.2=C" for current, the maximum signal you may select is 20.00 for a 0-20 or 4-20 mA dc signal output.*

16. Press the **▲/T1/T2▲** button to change the value of the flashing digit. If you continue to press the **▲/T1/T2▲** button, the flashing digit's value continues to change.
17. Press the **➤/DEV** button to scroll to the next digit.
18. Press the **MENU** button to store your selection. The meter momentarily shows **"STRD"** followed also momentarily by **"RST"** (Hard Reset). The meter then shows **"CJ.OF"** (Cold Junction Offset).



**WARNING:** *If the meter shows all flashing values on any item, the value has overflowed. Press the **▲/T1/T2▲** button to start new values.*

---

### 4.13 ENTERING COLD JUNCTION OFFSET (C.OF.1, C.OF.2)

You may enter Cold Junction offset for T1 input ("**C.OF.1**") and T2 input ("**C.OF.2**"). The cold junction offset equals the actual temperature minus the reading temperature. You may compensate for any error due to cold junction on the T1 or T2 inputs. You may perform this compensation in any temperature from 0 to 40°C, however we **recommend you perform this compensation at 0°C (32°F) for best results. To do this, immerse the thermocouple hot junctions into a mixture of ice and water.**

To perform this compensation, follow these steps:

1. Connect the thermocouple wire to the T1 or T2 inputs.
2. Press the **MENU** button until meter shows "**C.OF.1**" for T1 or "**C.OF.2**" for T2.
3. Press the **>/DEV** button. The meter shows the previous offset value with flashing 4th digit.
4. Press the **>/DEV** button again. The meter shows the temperature reading (no flashing digits).
- 5a. If this temperature reading is accurate, press the **MENU** button and the meter shows "**STRD**" (meter stores zero value for the offset).
- 5b. If this temperature reading is inaccurate, enter the accurate temperature using the **>/DEV** and **▲/T1/T2▲** buttons. Once you enter the accurate temperature, press the **MENU** button. The meter shows "**STRD**" and stores the offset value.



- 1: You may calibrate offsets in degrees Fahrenheit or Celsius. The meter flashes corresponding LED.**



- 2: Maximum/minimum offset value is  $\pm 10^{\circ}\text{C}$  ( $\pm 18^{\circ}\text{F}$ ). If the offset exceeds this value, the meter flashes "ER 4" and the offset value is not changed.**

## SECTION 5. ACCESSING THE DEVIATION MODE (DEV)

The deviation value is the difference between the "reading value" and "setpoint 1". The analog routing (**OUT**) item specifies which item (T1, T2 or T1 - T2) is the "reading value". Prior to accessing deviation mode, set **R.2=D** in Reading Configuration (**RD.CF**) - refer to Section 4.3.

To access the deviation mode:

1. In the "**RUN**" mode, press the **>/DEV** button. The meter momentarily shows "**DEV**", followed by the blinking deviation value.
2. If you have selected **0.3=A** in Output Configuration (**OT.CF** - refer to Section 8), press the **RESET** button. The meter exits the deviation mode and shows "**RUN**".

If you have selected **0.3=P** in Output Configuration, press the **RESET** button to tune your proportional controller (refer to Section 8). The meter shows "**TUNE**". "**TUNE**" is active if your meter has analog output capabilities.

## SECTION 6. MATCHING TWO INPUTS

The match mode matches Input 1 thermocouple with respect to Input 2. It considers any offset values with respect to Input 2 and applies this offset to match Input 1 to Input 2.

Prior to matching two inputs, set "**C.OF.1**" and "**C.OF.2**" to zero (cold junction offset, refer to Section 4.13). To set cold junction offset to zero, follow these steps:

1. Press the **MENU** button until meter shows "**C.OF.1**".
2. Press the **DEV** button twice.
3. Press the **MENU** button and the meter shows "**STRD**" (the meter sets the cold junction offset to zero).
4. The meter shows "**C.OF.2**".
5. Repeat steps 2 and 3.

Once the cold junction offset is set to zero, match two inputs following these steps:

1. Connect your thermocouples to the inputs and place both in the same temperature (Preferably 0°C, i.e. a mixture of ice and water).
2. Choose **R.2=M** in Reading Configuration (**RD.CF** - refer to Section 4.3) and press the **MENU** button to store the value. Press the **RESET** button twice to go back to the "**RUN**" mode.

## SECTION 6. MATCHING TWO INPUTS (Continued)

3. In the "RUN" mode, press the **➤/DEV** button. The meter shows "MTCH", indicating the meter is ready to go into the match mode (match mode has not started yet). Select one of the following:
  - 4a. To abort, press the **▲/T1/T2▲** button. The meter shows "RUN" and returns to the "RUN" mode.
  - 4b. To reset the match value, press the **RESET** button. The meter shows "MV.RS" and returns to the "RUN" mode.
  - 4c. To match two inputs, press the **➤/DEV** button. The meter flashes "MTCH" momentarily and in approximately 20 seconds performs matching. Once the meter performs matching, it performs a hard reset and returns to the "RUN" mode. Now you have a perfect match!



**1: Maximum/minimum match value is  $\pm 32\text{mV}$ . If the match value is greater than the capacity, the meter flashes "ER 3" and performs a hard reset. Previous match value is not changed.**



**2: During the match mode, pressing any button will abort the match mode. The match values do not change and the meter performs a hard reset and returns to the "RUN" mode.**

## SECTION 7. SELECTING METER DISPLAY

You may select one of two display reading modes:

- Normal Reading
  - +/- OPN Reading
1. If you select a decimal point for .1 degree resolution, the meter shows every value with the .1 degree unless this value is overflowed. If the value is overflowed, the value's decimal point (only) automatically changes to read 1 degrees resolution.
  2. Display reading is normal unless either T1 or T2 input goes outside the thermocouple range, or there is a sensor break. If either of these conditions occurs, the meter shows +OPN or -OPN according to the input value (refer to Table 7-1).

Table 7-1. Truth Table for Display Values

| T1     | T2     | T1 - T2 |
|--------|--------|---------|
| + Open | Normal | +Open   |
| -Open  | Normal | -Open   |
| Normal | +Open  | -Open   |
| Normal | -Open  | +Open   |
| +Open  | +Open  | +Open   |
| -Open  | -Open  | -Open   |
| +Open  | -Open  | +Open   |
| -Open  | +Open  | -Open   |

When +OPEN or -OPEN appears, T1, T2 or T1- T2 related alarms ignore their deadband and acts as follows:

| Display | Active Above Alarm | Active Below Alarm |
|---------|--------------------|--------------------|
| +OPN    | On                 | Not Effective      |
| -OPN    | Not Effective      | On                 |

## SECTION 8. TUNING THE PROPORTIONAL CONTROLLER

The proportional controller is not active unless your meter has analog output capabilities. The menu will display whether analog output is present or not.

To tune the proportional controller, select proportional on Output Configuration (**0.3=P**, refer to Section 4.8.3) and deviation in Reading Configuration (**R.2=D**, refer to Section 4.3) **prior** to tuning your controller. Include the meter in the process loop and turn on the meter. Allow enough time for the system to settle, and then do the following:

1. Press the **➤/DEV** button. The meter momentarily shows "**DEV**" followed by a blinking value. This is the deviation (error) between Reading and Setpoint 1 values. If zero shows there is no error and your controller is tuned. If a value other than zero shows, proceed with step 2.
2. Press the **RESET** button. The meter shows "**TUNE**", tuning your controller and canceling any error. Once tuned, the meter shows "**RST**" and returns to the "**RUN**" mode.
3. Allow enough time for process to settle. Press the **➤/DEV** button. Verify that the blinking value is zero. If the blinking value is not zero, repeat step 2.

# SECTION 9 DISPLAY MESSAGES

Table 9-1. Display Messages

|                | DESCRIPTION   |
|----------------|---|
| <b>RST</b>     | Hard (power on) Reset   |
| <b>INPT</b>    | Input Type  |
| <b>DEC.P</b>   | Decimal Point   |
| <b>C.OF.1</b>  | Cold Junction Offset for T1 input   |
| <b>C.OF.2</b>  | Cold Junction Offset for T2 input   |
| <b>RD.CF</b>   | Reading Configuration   |
| <b>S1.CF</b>   | Setpoint 1 Configuration  |
| <b>S2.CF</b>   | Setpoint 2 Configuration  |
| <b>S1.DB</b>   | Setpoint 1 Deadband   |
| <b>S2.DB</b>   | Setpoint 2 Deadband   |
| <b>OT.CF</b>   | Output Configuration  |
| <b>OUT</b>     | Analog Output Routings  |
| <b>P.BND</b>   | Proportional Band   |
| <b>M.RST</b>   | Manual Reset  |
| <b>±OPN</b>    | Sensor Breaker or Temperature Outside the Range   |
| <b>9999</b>    | Value Overflow in Setpoint/Menu Peak Deviation Routine  |
| <b>-1999</b>   | Value Overflow in Setpoint/Menu Peak Deviation Routine  |
| <b>ER1</b>     | 2 Coordinate Format Programming Error   |
| <b>OT.SO</b>   | Output Scale and Offset   |
| <b>CJ.OF</b>   | Cold Junction Offset  |
| <b>SP.RS</b>   | Reset Setpoints   |
| <b>TUNE</b>    | Tuning Proportional Controller  |
| <b>SP1</b>     | Setpoint 1 Value  |
| <b>SP2</b>     | Setpoint 2 Value  |
| <b>T1</b>      | Channel 1 Temperature Reading   |
| <b>T2</b>      | Channel 2 Temperature Reading   |
| <b>T1 - T2</b> | Differential Reading  |
| <b>MTCH</b>    | Match Mode  |
| <b>MV.RS</b>   | Match Value Reset   |
| <b>ER2</b>     | One or more the following items have overflowed because of decimal point change: Setpoint Values, Setpoint Deadbands, Proportional Bands or Manual Reset. |
| <b>ER3</b>     | Match Value is larger than the limit.   |
| <b>ER4</b>     | Cold Junction offset value is larger than the limit.  |



# SECTION 10. MENU CONFIGURATION

Table 10-1. Configuration Menu (Defaults in bold and italics)

|       | SUBMENU                                     | DESCRIPTION  |
|-------|---|--|
| INPT  | J.TC<br><b><i>K.TC</i></b><br>T.TC<br>DJ.TC | <b>INPUT TYPE</b><br>Type J T/C<br><b><i>Type K T/C</i></b><br>Type T T/C<br>Type DINJ T/C   |
| DEC.P | FFFF.<br><b><i>FFF.F</i></b>                | <b>DECIMAL POINT POSITION</b><br>Select to display whole degrees or tenths of a degree.  |
| RD.CF | R.1<br><br>R.2                              | <b>READING CONFIGURATION</b><br>Select unit of temperature:<br>C: Celsius<br><b><i>F: Fahrenheit</i></b><br><br><b><i>D: ^/DEV button for deviation</i></b><br><b><i>M: ^/DEV button for match mode</i></b>  |
| S1.CF | S.1<br><br>S.2<br><br>S.3                   | <b>SETPOINT 1 CONFIGURATION:</b><br><b><i>A: Active above</i></b><br><b><i>B: Active below</i></b><br><br><b><i>U: Unlatched</i></b><br><b><i>L: Latched</i></b><br><br><b><i>0: Assign to T1 - T2</i></b><br><b><i>1: Assign to T1</i></b><br><b><i>2: Assign to T2</i></b> |
| S2.CF | S.1<br><br>S.2<br><br>S.3                   | <b>SETPOINT 2 CONFIGURATION:</b><br><b><i>A: Active above</i></b><br><b><i>B: Active below</i></b><br><br><b><i>U: Unlatched</i></b><br><b><i>L: Latched</i></b><br><br><b><i>0: Assign to T1 - T2</i></b><br><b><i>1: Assign to T1</i></b><br><b><i>2: Assign to T2</i></b> |
| S1.DB | 0000 through 9999                           | <b>SETPOINT 1 DEADBAND</b><br>Select from 0000 through 9999  |
| S2.DB | 0000 through 9999                           | <b>SETPOINT 2 DEADBAND</b><br>Select from 0000 through 9999  |

## SECTION 10 MENU CONFIGURATION (Continued)

|                  | SUBMENU                    | DESCRIPTION  |
|------------------|----------------------------|--|
| OT.CF            |                            | OUTPUT CONFIGURATION<br>Analog Output:   |
|                  | 0.1                        | D: Disabled<br><b>E: Enabled</b>   |
|                  | 0.2                        | V: Voltage analog out<br><b>C: Current analog out</b>  |
|                  | 0.3                        | <b>A: Follows the display value</b><br>P: Proportional to Setpoint 1   |
|                  | 0.4                        | D: Direct reading<br>R: Reverse acting   |
|                  | 0.5                        | F: 0-10 V proportional<br>H: 0-5 V proportional  |
| OUT              | T1<br>T2<br><b>T1 - T2</b> | T1 value on analog out and deviation<br>T2 value on analog out and deviation<br><b>T1 - T2 value on analog out and deviation</b> |
| P.BND            | 0000 through 9999          | <b>PROPORTIONAL BAND</b><br>Select from 0000 through 9999  |
| M.RST            | -1999 through 9999         | <b>MANUAL RESET</b><br>Select from -1999 through 9999  |
| OT.S.O           | -1999 through 9999         | <b>OUTPUT SCALE AND OFFSET</b><br>2-coordinate format for scaling the analog output  |
| C.OF.1<br>C.OF.2 | -1999 through 9999         | <b>COLD JUNCTION OFFSET</b><br>Select from -1999 through 9999 in °C or °F.   |

# SECTION 11. FRONT PANEL DISPLAYS

Table 11-1. Front Panel Displays

|              | >/DEV                  | ^/T1/T2^                             | DESCRIPTION  |
|--------------|------------------------|--------------------------------------|--|
| <b>INPT</b>  | Show input choices     | J.TC<br><i>K.TC</i><br>T.TC<br>DJ.TC | <b>SIGNAL INPUT</b><br>J T/C<br><i>K T/C</i><br>T T/C<br>DIN J T/C                       |
| <b>DEC.P</b> | Show input choices     | FFFF.<br><i>FFF.F</i>                | <b>DECIMAL POINT</b>   |
| <b>RD.CF</b> | <b>R.1</b>             | <i>F</i><br>C                        | <b>READING CONFIGURATION</b><br><br><i>Show in °F</i><br>Show in °C                      |
|              | <b>R.2</b>             | <i>D</i><br><br>M                    | <i>^/DEV button for deviation</i><br>^/DEV button for match mode                         |
| <b>S1.CF</b> | <b>S.1</b>             | <i>A</i><br>B                        | <b>SETPOINT 1 CONFIGURATION</b><br><br><i>Active above</i><br>Active below               |
|              | <b>S.2</b>             | <i>U</i><br>L                        | <i>Unlatched</i><br>Latched  |
|              | <b>S.3</b>             | <i>0</i><br>1<br>2                   | <i>Assign to T1 - T2</i><br>Assign to T1<br>Assign to T2                                 |
| <b>S2.CF</b> | <b>S.1</b>             | <i>A</i><br>B                        | <b>SETPOINT 2 CONFIGURATION</b><br><br><i>Active above</i><br>Active below               |
|              | <b>S.2</b>             | <i>U</i><br>L                        | <i>Unlatched</i><br>Latched  |
|              | <b>S.3</b>             | <i>0</i><br>1<br>2                   | <i>Assign to T1 - T2</i><br>Assign to T1<br>Assign to T2                                 |
| <b>S1.DB</b> | Scroll right one digit | Change the flashing digit's value    | <b>SETPOINT 1 DEADBAND</b><br><br>Select from 0000 through 9999. (Factory preset is 3.0) |
| <b>S2.DB</b> | Scroll right one digit | Change the flashing digit's value    | <b>SETPOINT 2 DEADBAND</b><br><br>Select from 0000 through 9999. (Factory preset is 3.0) |

## SECTION 11 Front panel Display (Continued)

|   | >/DEV  | ^/T1/T2^                           | DESCRIPTION  |
|---|--|------------------------------------|--|
| <b>OT.CF</b>  | 0.1  | D<br>E                             | <b>OUTPUT CONFIG</b><br>Disable analog output<br><i>Enable analog output</i> |
|   | 0.2  | V<br>C                             | Analog output = voltage<br><i>Analog output = current</i>                    |
|   | 0.3  | A<br>P                             | Regular analog output<br>Proportional analog output                          |
|   | 0.4  | D                                  | Proportional analog output is direct acting                                  |
|   |  | R                                  | Proportional analog output is reverse acting                                 |
|   | 0.5  | F<br>H                             | Analog output is 0-10 V dc<br>Analog output is 0-5 V dc                      |
| <p><b>Notes:</b> * If you select 0.2 = V, you may select your analog output to be 0-10 V or 0-5 V by accessing submenu <b>0.5</b>.</p> <p>* If you select 0.3 = 0, you have access to Output Scale and Offset.</p> <p>* If you select 0.3 = P, you may select your proportional output analog to be direct or reverse acting (i.e. 4-20 or 20-4).</p> |  |                                    |  |
| <b>OT.S.O</b>   | Press to show <b>RD 1</b><br>and prior value entered |                                    | <b>OUTPUT SCALE AND OFFSET</b>   |
| Enter new value and show <b>OUT1</b>  | Scroll right one digit                               | Change the flashing digit's value. |  |
| Enter new value and show <b>RD 2</b>  | Show prior value entered.                            |                                    |  |
| Enter new value and show <b>OUT2</b>  | Scroll right one digit                               | Change the flashing digit's value. |  |
|   | Show prior value entered.                            |                                    |  |
|   | Scroll right one digit                               | Change the flashing digit's value. |  |
| <b>PBND</b>   | Scroll right one digit                               | Change the flashing digit's value  | <b>PROPORTIONAL BAND</b><br>Select from 0000 through 9999                    |
| <b>M.RST</b>  | Scroll right one digit                               | Change the flashing digit's value  | <b>MANUAL RESET</b><br>Select from -1999 through 9999                        |

## SECTION 11. FRONT-PANEL DISPLAYS (Continued)

Table 11-2. "RUN" Mode Displays

| DISPLAY                 | >/DEV   | ▲/T1/T2▲                 | RESET  | DESCRIPTION   |
|-------------------------|---|--------------------------|--|---|
| <b>DEV</b><br>If R.2=D  | Activate  | Exit from deviation mode | If 0.3=A, then exit from deviation mode. Meter shows "RUN".<br><br>If 0.3=P, then tune the controller. | Shows deviation value.  |
| <b>MTCH</b><br>If R.2=M | Press once to display. Press twice to activate match process. | Abort match.             | Reset the match value.   |   |
| "RUN" mode              |   |                          |  | <b>LATCHED RESET</b><br><br>Pressing the <b>RESET</b> button will reset your setpoints. |

## SECTION 12. SETPOINT CONFIGURATION DISPLAYS

Table 12-1. Setpoint Configuration Displays

| MENU | ➤/DEV                  | ▲/T1/T2/▲                         | DESCRIPTION   |
|------|------------------------|-----------------------------------|---|
| SP 1 | Scroll right one digit | Change the flashing digit's value | <b>SETPOINT 1</b><br>Select from -1999 through 9999 |
| SP 2 | Scroll right one digit | Change the flashing digit's value | <b>SETPOINT 2</b><br>Select from -1999 through 9999 |

## SECTION 13. SPECIFICATIONS

### SIGNAL INPUT

#### Thermocouple

#### Types:

#### **J - Iron vs. Constantan (NIST)**

Temperature Range: -210° through 760°C  
(-346° through 1400°F)

#### **K - Chromel vs. Alumel (NIST)**

Temperature Range: -270° through 1372°C  
(-454° through 2500°F)

#### **T - Copper vs. Copper-Nickel (NIST)**

Temperature Range: -270° to 400° C  
(-454° to 752°F)

#### **DIN J - Iron vs. Constantan (DIN)**

Temperature Range: -200° through 900°C (-  
328° through 1652°F)

#### Isolation:

Dielectric strength to 2500V transient per  
3mm spacing based on EN 61010 for  
260Vrms or dc working voltage  
NMR- 60 dB  
CMR- 120 dB

**Cross Channel Isolation:** 108 db; up to ±5V between 2 inputs

#### Display:

LED 14 segment  
13.8 mm (0.54")  
red or green

#### Symbols:

8888 (-1.9.9.9. ~ 9.9.9.9.)

## SECTION 13. SPECIFICATIONS (Continued)

### ANALOG TO DIGITAL

|                                   |   |
|-----------------------------------|---|
| <b>Technique:</b>                 | Dual slope  |
| <b>Internal resolution:</b>       | 15 bits   |
| <b>Read rate:</b>                 | 3/seconds for each channel  |
| <b>Polarity:</b>                  | Automatic   |
| <b>ACCURACY AT 25°C:</b>          | $\pm 0.5^{\circ}\text{C}$ for temperature above $-100^{\circ}\text{C}$<br>$\pm 1^{\circ}\text{C}$ for temperature above $+1000^{\circ}\text{C}$<br>$\pm 1^{\circ}\text{C}$ for temperature below $-100^{\circ}\text{C}$ |
| <b>Temperature Stability:</b>     | $0.05^{\circ}\text{C}/^{\circ}\text{C}$   |
| <b>Step response:</b>             | 1 second to 99% of the final value  |
| <b>Warm up to rated accuracy:</b> | 30 minutes  |

### ANALOG OUTPUT (if applicable)

|                            |   |
|----------------------------|---|
| <b>Signal type:</b>        | Current or voltage  |
| <b>Signal level:</b>       |   |
| <b>Current:</b>            | 10V maximum compliance at 20 mA output  |
| <b>Voltage:</b>            | 20 mA maximum for 0-10V output  |
| <b>Function:</b>           | May be assigned to a display range or proportional control output with setpoint #1 when used as a control output. |
| <b>Linearity:</b>          | 0.2%  |
| <b>Step Response Time:</b> | 2 seconds to 99% of the final value   |

### ISOLATED ANALOG OUTPUT (if applicable)

*Same as non-isolated analog output, except isolated to 1000Vdc*



Only one analog output is available on each unit and it must be factory installed.



## SECTION 13. SPECIFICATIONS (continued)

### ALARM OUTPUTS (if applicable)

2 Form "C" on/off relays. Configurable for latched and unlatched by software.

Max current: 5 AMPS, resistive load  
Max voltage: 250 Vac or 30 Vdc

### ENVIRONMENT

#### ~ AC units

115/230 V~(AC)  $\pm$  10%, 50/60 Hz  
7 W max, power consumption (Non-Isolated Analog Out)  
8 W max, power consumption (Isolated Analog Out)

#### --- DC units

10-32 Vdc or 26-56 Vdc,  
6 W max, power consumption (Non-Isolated Analog Out)  
7 W max, power consumption (Isolated Analog Out)

### External Fuse Required:

| IEC 127-2/III           |                          |
|-------------------------|--------------------------|
| Power                   | Fuse                     |
| 115 V                   | 125 mA @ 250 (T)         |
| 230 V                   | 63 mA @ 250 (T)          |
| UL 248-14 (Listed Fuse) |                          |
| Power                   | Fuse                     |
| 115 V                   | 175 mA @ 250 V Slow-Blow |
| 230 V                   | 80 mA @ 250 V Slow-Blow  |

### ENVIRONMENT

#### Operating temperature:

0° to 50°C (32° to 122°F)  
(115/230 V rms  $\pm$  10%)

#### Storage temperature:

-40° to 85°C (-40° to 185° F)

#### Relative humidity:

90% at 40°C (non-condensing)

### MECHANICAL

#### Panel cutout:

1/8 DIN 3.62 x 1.78" (45 x 92mm)

#### Weight:

1.27 lb (575 g)

#### Case material:

Polycarbonate, 94 V-O UL rated

#### Protection:

NEMA-4/Type 4 Front Bezel

SECTION 13. SPECIFICATIONS (continued)

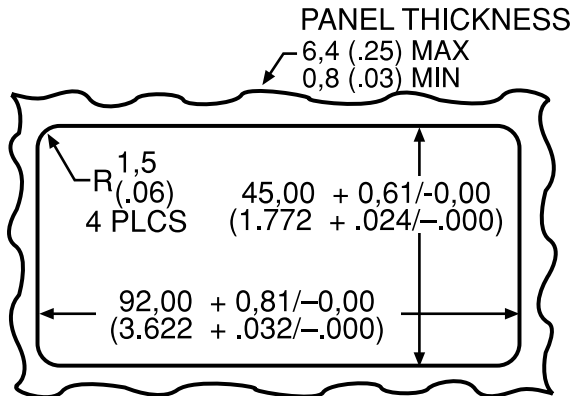
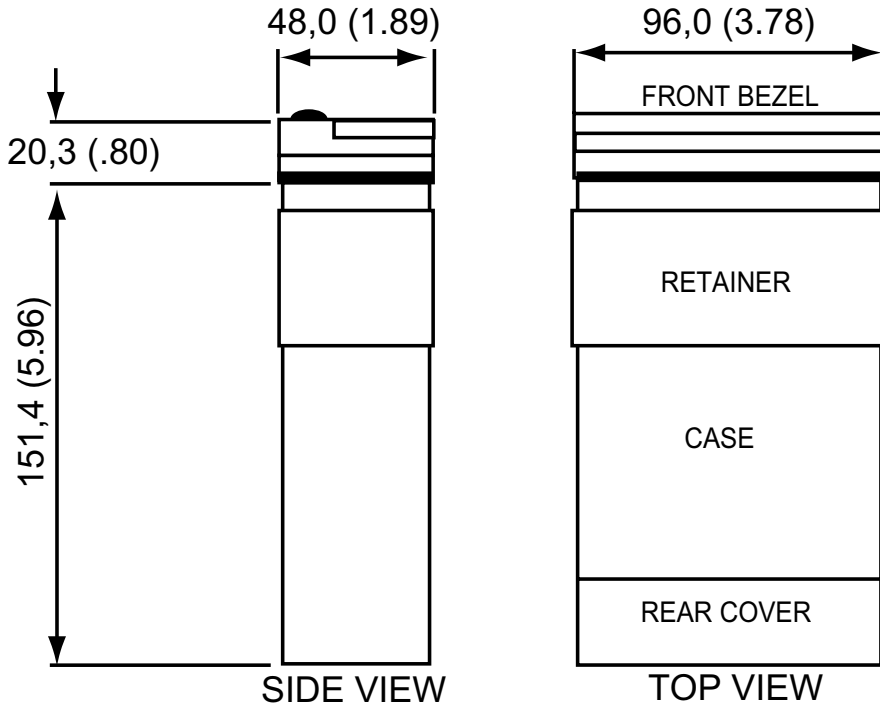

NOTE: Dimensions in Millimeters (Inches)

Figure 13-1 Meter Dimensions

## SECTION 14. FACTORY PRESET VALUES

**Table 14-1. Factory Preset Values**

| MENU ITEM     | FACTORY PRESET VALUES   |
|---------------|---|
| <b>INPT</b>   | Input Type: <b>K.TC</b> (Type K T/C)  |
| <b>DEC.P</b>  | Decimal Point Position: <b>FFF.F</b>  |
| <b>RD.CF</b>  | Reading Configuration:<br><b>R.1=F</b> (Fahrenheit)<br><b>R.2=D</b> (Shows deviation in "RUN" mode)   |
| <b>S1.CF</b>  | Setpoint 1 Configuration:<br><b>S.1=A</b> (Setpoint is active above)<br><b>S.2=U</b> (Setpoint is unlatched)<br><b>S.3=0</b> (Setpoint 1 assigned to T1 - T2)         |
| <b>S2.CF</b>  | Setpoint 2 Configuration:<br><b>S.1=A</b> (Setpoint is active above)<br><b>S.2=U</b> (Setpoint is unlatched)<br><b>S.3=0</b> (Setpoint 2 assigned to T1 - T2)         |
| <b>S1.DB</b>  | Setpoint 1 Deadband: <b>3.0</b>   |
| <b>S2.DB</b>  | Setpoint 2 Deadband: <b>3.0</b>   |
| <b>OT.CF</b>  | Output Configuration:<br><b>O.1=E</b> (Analog output is enabled)<br><b>O.2=C</b> (Analog output is current)<br><b>O.3=A</b> (Analog output follows the display value) |
| <b>OUT</b>    | Analog Output Routing: T1 - T2  |
| <b>OT.S.O</b> | Output Scale and Offset:<br>0-1000 = 4-20 mA dc   |
| <b>C.OF.1</b> | Cold Junction Offset for T1: 000.0<br>Cold Junction Offset for T2: 000.0  |
| <b>SP1</b>    | Setpoint 1 Value: 000.0   |
| <b>SP2</b>    | Setpoint 2 Value: 000.0   |

## CE APPROVALS INFORMATION

 This product conforms to the EMC directive 89/336/EEC amended by 93/68/EEC, and with the European Low Voltage Directive 72/23/EEC.

### Electrical Safety EN61010-1:2001

Safety requirements for electrical equipment for measurement, control and laboratory.

#### Double Insulation

#### Pollution Degree 2

#### Dielectric withstand Test per 1 min

- Power to Input/Output: 2300 Vac (3250 Vdc)
- Power to Input/Output: 500 Vac (720 Vdc)  
(Low Voltage dc Power Option\*)
- Power to Relays Output: 2300 Vac (3250 Vdc)
- Relay 1 to Relay 2: 2300 Vac (3250 Vdc)
- Isolated Analog to Inputs: 1000 Vac (1420 Vdc)
- Analog to Inputs: No Isolation

#### Measurement Category I

Category I are measurements performed on circuits not directly connected to the Mains Supply (power). Maximum Line-to-Neutral working voltage is 50 Vac/dc. This unit should not be used in Measurement Categories II, III, IV.

#### Transients Overvoltage Surge (1.2 / 50uS pulse)

- Input Power: 2500 V
- Input Power: 500 V  
(Low Voltage dc Power Option\*)
- Isolated Analog: 500 V
- Input/Output Signals: 500 V

**Note:** \*Units configured for external low power dc voltage, 10-32 Vdc (Basic Insulation)

### EMC EN61326:1997 + and A1:1998 + A2:2001

Immunity and Emissions requirements for electrical equipment for measurement, control and laboratory.

- EMC Emissions Table 4, Class B of EN61326
- EMC Immunity\*\* Table 1 of EN61326

**Note:** \*\*I/O signal and control lines require shielded cables and these cables must be located on conductive cable trays or in conduits. Furthermore, the length of these cables should not exceed 30 meters



Refer to the EMC and Safety installation considerations (Guidelines) of this manual for additional information.





## Warranty/Disclaimer

NEWPORT Electronics, Inc. warrants this unit to be free of defects in materials and workmanship for a period of **one (1) year** from the date of purchase. In addition to NEWPORT's standard warranty period, NEWPORT Electronics will extend the warranty period for **four (4) additional years** if the warranty card enclosed with each instrument is returned to NEWPORT.

If the unit should malfunction, it must be returned to the factory for evaluation. NEWPORT's Customer Service Department will issue an Authorized Return (AR) number immediately upon phone or written request. Upon examination by NEWPORT, if the unit is found to be defective it will be repaired or replaced at no charge. NEWPORT's WARRANTY does not apply to defects resulting from any action of the purchaser, including but not limited to mishandling, improper interfacing, operation outside of design limits, improper repair, or unauthorized modification. This WARRANTY is VOID if the unit shows evidence of having been tampered with or shows evidence of being damaged as a result of excessive corrosion; or current, heat, moisture or vibration; improper specification; misapplication; misuse or other operating conditions outside of NEWPORT's control. Components which wear are not warranted, including but not limited to contact points, fuses, and triacs.

**NEWPORT is pleased to offer suggestions on the use of its various products. However, NEWPORT neither assumes responsibility for any omissions or errors nor assumes liability for any damages that result from the use of its products in accordance with information provided by NEWPORT, either verbal or written. NEWPORT warrants only that the parts manufactured by it will be as specified and free of defects. NEWPORT MAKES NO OTHER WARRANTIES OR REPRESENTATIONS OF ANY KIND WHATSOEVER, EXPRESSED OR IMPLIED, EXCEPT THAT OF TITLE, AND ALL IMPLIED WARRANTIES INCLUDING ANY WARRANTY OF MERCHANTABILITY AND FITNESS FOR A PARTICULAR PURPOSE ARE HEREBY DISCLAIMED. LIMITATION OF LIABILITY: The remedies of purchaser set forth herein are exclusive and the total liability of NEWPORT with respect to this order, whether based on contract, warranty, negligence, indemnification, strict liability or otherwise, shall not exceed the purchase price of the component upon which liability is based. In no event shall NEWPORT be liable for consequential, incidental or special damages.**

CONDITIONS: Equipment sold by NEWPORT is not intended to be used, nor shall it be used: (1) as a "Basic Component" under 10 CFR 21 (NRC), used in or with any nuclear installation or activity; or (2) in medical applications or used on humans. Should any Product(s) be used in or with any nuclear installation or activity, medical application, or used on humans, or misused in any way, NEWPORT assumes no responsibility as set forth in our basic WARRANTY / DISCLAIMER language, and additionally purchaser will indemnify NEWPORT and hold NEWPORT harmless from any liability or damage whatsoever arising out of the use of the Product(s) in such a manner.

## Return Requests/Inquiries

Direct all warranty and repair requests/inquiries to the NEWPORT Customer Service Department. **BEFORE RETURNING ANY PRODUCT(S) TO NEWPORT, PURCHASER MUST OBTAIN AN AUTHORIZED RETURN (AR) NUMBER FROM NEWPORT'S CUSTOMER SERVICE DEPARTMENT (IN ORDER TO AVOID PROCESSING DELAYS).** The assigned AR number should then be marked on the outside of the return package and on any correspondence.

The purchaser is responsible for shipping charges, freight, insurance and proper packaging to prevent breakage in transit.

FOR **WARRANTY** RETURNS, please have the following information available BEFORE contacting NEWPORT:

1. P.O. number under which the product was PURCHASED,
2. Model and serial number of the product under warranty, and
3. Repair instructions and/or specific problems relative to the product.

FOR **NON-WARRANTY** REPAIRS, consult NEWPORT for current repair charges. Have the following information available BEFORE contacting NEWPORT:

1. P.O. number to cover the COST of the repair,
2. Model and serial number of product, and
3. Repair instructions and/or specific problems relative to the product.

NEWPORT's policy is to make running changes, not model changes, whenever an improvement is possible. This affords our customers the latest in technology and engineering.

NEWPORT is a registered trademark of NEWPORT Electronics, Inc.

© Copyright 2007 NEWPORT Electronics, Inc. All rights reserved. This document may not be copied, photocopied, reproduced, translated, or reduced to any electronic medium or machine-readable form, in whole or in part, without prior written consent of NEWPORT Electronics, Inc.

---

For immediate technical or application assistance please call:

**1-800-6397678®**  
**1-800-NEWPORT**

---

Newport Electronics, Inc.  
2229 South Yale Street • Santa Ana, CA • 92704 • U.S.A.  
TEL: (714) 540-4914 • FAX: (203) 968-7311  
Toll Free: 1-800-639-7678 • [www.newportUS.com](http://www.newportUS.com) • e-mail: [info@newportUS.com](mailto:info@newportUS.com)  
ISO 9001 Certified

---

Newport Technologies, Inc.  
976 Bergar • Laval (Quebec) • H7L 5A1 • Canada  
TEL: (514) 335-3183 • FAX: (514) 856-6886  
Toll Free: 1-800-639-7678 • [www.newport.ca](http://www.newport.ca) • e-mail: [info@newport.ca](mailto:info@newport.ca)

---

Newport Electronics, Ltd.  
One Omega Drive • River Bend Technology Centre  
Northbank, Irlam • Manchester M44 5BD • United Kingdom  
Tel: +44 161 777 6611 • FAX: +44 161 777 6622  
Toll Free: 0800 488 488 • [www.newportuk.co.uk](http://www.newportuk.co.uk) • e-mail: [sales@newportuk.co.uk](mailto:sales@newportuk.co.uk)

---

Newport Electronics B.V. - Benelux  
TEL: +31 20 3472121 • FAX: +31 20 6434643  
Toll Free: 0800 0993344 • [www.newport.nl](http://www.newport.nl) • e-mail: [info@newport.nl](mailto:info@newport.nl)

---

Newport Electronics spol s.r.o.  
Frystatska 184, 733 01 Karviná • Czech Republic  
TEL: +420 59 6311899 • FAX: +420 59 6311114  
Toll Free: 0800-1-66342 • [www.newport.cz](http://www.newport.cz) • e-mail: [info@newport.cz](mailto:info@newport.cz)

---

Newport Electronics GmbH  
Daimlerstrasse 26 • D-75392 Deckenpfronn • Germany  
TEL: 49 7056 9398-0 • FAX: 49 7056 9398-29  
Toll Free: 0800 / 6397678 • [www.newport.de](http://www.newport.de) • e-mail: [sales@newport.de](mailto:sales@newport.de)

---

Newport Electronique S.A.R.L. - France  
TEL: +33 1 61 37 29 00 • FAX: +33 1 30 57 54 27  
Toll Free: 0800 466 342 • [www.newport.fr](http://www.newport.fr) • e-mail: [sales@newport.fr](mailto:sales@newport.fr)

---

Mexico and Latin America  
FAX: 001 (203) 359-7807  
TEL En Español: 001 (203) 359-7803

|  |
|--|
| <b>NEWPORTnet™ On-Line Service</b><br><a href="http://www.newportUS.com">www.newportUS.com</a> |
|--|

|  |
|--|
| <b>Internet e-mail</b><br><a href="mailto:info@newportUS.com">info@newportUS.com</a> |
|--|

 **NEWPORT** Electronics, Inc.