

Low voltage 16-bit constant current LED sink driver with output error detection and auto power-saving for automotive applications

Datasheet - production data



Description

The STAP16DPS05 is a monolithic, low voltage, low current power 16-bit shift register designed for LED panel displays. The device contains a 16-bit serial-in, parallel-out shift register that feeds a 16-bit D-type storage register. In the output stage, sixteen regulated current sources are designed to provide 5-100 mA constant current to drive the LEDs.

The STAP16DPS05 features the open and short LED detections on the outputs. The STAP16DPS05 ensures the backward compatibility with the STP16C/L596. The detection circuit checks 3 different conditions, which can occur on the output line: short to GND, short to V_O or open line. The data detection results are loaded in the shift register and shifted out via the serial line output. The detection functionality is implemented without increasing the pin number. Through a secondary function of the output enable and latch pin (DM1 and DM2 respectively), a dedicated logic sequence allows the device to enter or leave detection mode. Through an external resistor, users can adjust the output current of the STAP16DPS05, thus controlling the light intensity of the LEDs. In addition, the user can adjust the intensity of the brightness of the LEDs from 0% to 100% through the $\overline{OE/DM2}$ pin.

The STAP16DPS05 guarantees a 20 V output driving capability, allowing users to connect more LEDs in series. The high clock frequency, 30 MHz, also satisfies the system requirement of high volume data transmission. The 3.3 V of voltage supply is very useful for applications that interface any microcontroller from 3.3 V micro. Compared with a standard TSSOP package, the TSSOP exposed pad increases the capability of heat dissipation by a factor of 2.5.

Features

- Low voltage power supply down to 3 V
- 16 constant current output channels
- Adjustable output current through external resistor
- Short and open output error detection
- Serial data IN/parallel data OUT
- 3.3 V micro driver-able
- Output current: 5-100 mA
- Auto power-saving
- Max. clock frequency: 30 MHz
- 20 V current generator rated voltage
- Power supply voltage: from 3 V to 5.5 V
- Thermal shutdown for overtemperature protection
- ESD protection 2.0 kV HBM

Applications

- Dashboard and infotainment backlighting
- Exterior/interior lighting
- DTRLs

Table 1. Device summary

Order code	Package	Packaging
STAP16DPS05XTTR	HTSSOP24 (exposed pad)	2500 parts per reel

Contents

- 1 Summary description 5**
 - 1.1 Pin connections and description 5

- 2 Electrical ratings 6**
 - 2.1 Absolute maximum ratings 6
 - 2.2 Thermal data 6
 - 2.3 Recommended operating conditions 6

- 3 Electrical characteristics 8**
 - 3.1 Switching characteristics 9

- 4 Equivalent circuit and outputs 11**

- 5 Timing diagrams 13**

- 6 Typical characteristics 16**

- 7 Detection mode functionality 19**
 - 7.1 Phase one: “entering in detection mode” 19
 - 7.2 Phase two: “error detection” 20
 - 7.3 Phase three: “resuming to normal mode” 22
 - 7.4 Error detection conditions 22
 - 7.5 Auto power-saving 26

- 8 Package mechanical data 29**

- 9 Packaging mechanical data 31**

- 10 Revision history 33**



List of tables

Table 1.	Device summary	1
Table 2.	Typical current accuracy	5
Table 3.	Pin description	5
Table 4.	Absolute maximum ratings	6
Table 5.	Thermal data	6
Table 6.	Recommended operating conditions	6
Table 7.	Electrical characteristics	8
Table 8.	Switching characteristics	9
Table 9.	Truth table	13
Table 10.	Output current- R_{EXT} resistor	16
Table 11.	ISET vs. dropout voltage (V_{drop})	17
Table 12.	Entering in detection truth table	19
Table 13.	Detection conditions	22
Table 14.	IODEC average value at 3.3 V	25
Table 15.	IODEC average value at 5 V	25
Table 16.	TSSOP24 exposed pad mechanical data	30
Table 17.	Tape and reel TSSOP24 exposed pad	32
Table 18.	Document revision history	33

List of figures

Figure 1.	Pin connections	5
Figure 2.	OE/DM2 terminal	11
Figure 3.	LE/DM1 terminal	11
Figure 4.	CLK, SDI terminal	11
Figure 5.	SDO terminal	12
Figure 6.	Block diagram	12
Figure 7.	Timing diagram	13
Figure 8.	Clock, serial-in, serial-out	14
Figure 9.	Clock, serial-in, latch, enable, outputs	15
Figure 10.	Outputs	15
Figure 11.	Output current- R_{EXT} resistor	16
Figure 12.	ISET vs. dropout voltage (V_{drop})	17
Figure 13.	IDD ON/OFF	18
Figure 14.	Entering in detection timing diagram	19
Figure 15.	Detection diagram	20
Figure 16.	Timing example for open and/or short detection	21
Figure 17.	Resuming to normal mode timing diagram	22
Figure 18.	Detection circuit	23
Figure 19.	Error detection sequence.	24
Figure 20.	Error detection typical schematic	24
Figure 21.	Auto power-saving feature.	26
Figure 22.	Delay LE-OUT	27
Figure 23.	Auto power-saving behavior	28
Figure 24.	TSSOP24 exposed pad dimensions	29
Figure 25.	TSSOP24 exposed pad tape and reel dimensions	31

1 Summary description

Table 2. Typical current accuracy

Output voltage	Current accuracy		Output current	V _{DD}	Temperature
	Between bits	Between ICs			
≥ 1.3 V	±1.5%	±5%	20 to 100 mA	3.3 V to 5 V	25 °C

1.1 Pin connections and description

Figure 1. Pin connections

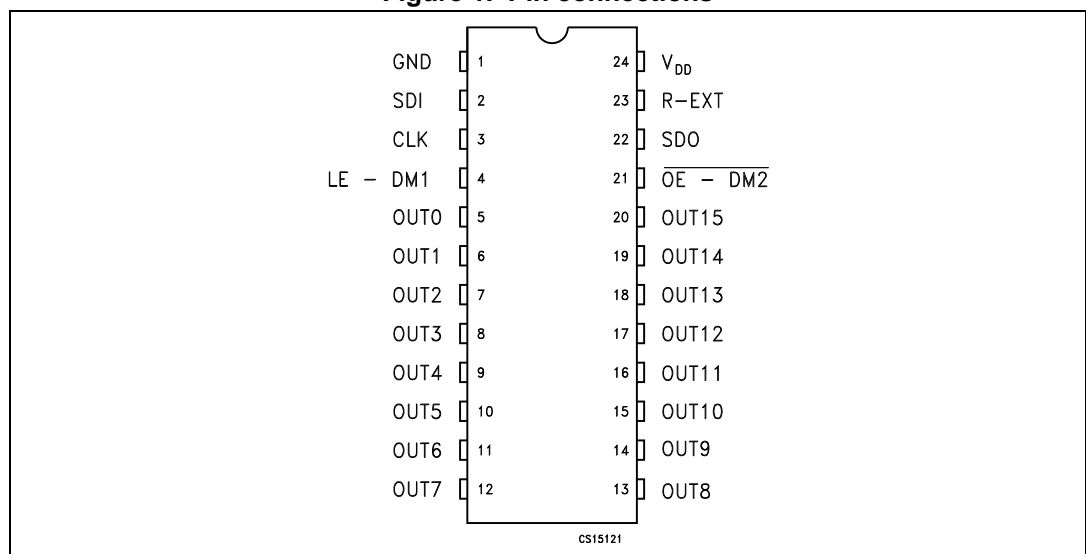

Note: The exposed pad is electrically connected to a metal layer electrically isolated or connected to ground.

Table 3. Pin description

Pin n°	Symbol	Name and function
1	GND	Ground terminal
2	SDI	Serial data input terminal
3	CLK	Clock input terminal
4	LE/DM1	Latch input terminal - detect mode 1 (see operation principle)
5-20	OUT-15	Output terminal
21	$\overline{OE/DM2}$	Input terminal of output enable (active low) - detect mode 1 (see operation principle)
22	SDO	Serial data out terminal
23	R-EXT	Input terminal of an external resistor for constant current programming
24	V _{DD}	Supply voltage terminal

2 Electrical ratings

2.1 Absolute maximum ratings

Stressing the device above the rating listed in the “absolute maximum ratings” table may cause permanent damage to the device. These are stress ratings only and operation of the device at these or any other conditions above those indicated in the operating sections of this specification is not implied. Exposure to absolute maximum rating conditions for extended periods may affect device reliability.

Table 4. Absolute maximum ratings

Symbol	Parameter	Value	Unit
V_{DD}	Supply voltage	0 to 7	V
V_O	Output voltage	-0.5 to 20	V
I_O	Output current	100	mA
V_I	Input voltage	-0.4 to V_{DD}	V
I_{GND}	GND terminal current	1600	mA
f_{CLK}	Clock frequency	50	MHz
T_{OPR}	Operating temperature range	-40 to +150	°C
T_{STG}	Storage temperature range	-55 to +150	°C

2.2 Thermal data

Table 5. Thermal data

Symbol	Parameter	Value	Unit
$R_{th(JA)}$	Thermal resistance junction-ambient ⁽¹⁾	TSSOP24 ⁽²⁾ exposed pad	37.5 °C/W

1. According to JEDEC standard 51-7B.

2. The exposed pad should be soldered to the PCB in order to derive the thermal benefits.

2.3 Recommended operating conditions

Table 6. Recommended operating conditions

Symbol	Parameter	Test conditions	Min.	Typ.	Max.	Unit
V_{DD}	Supply voltage		3.0	-	5.5	V
V_O	Output voltage			-	20	V
I_O	Output current	OUTn	5	-	100	mA
I_{OH}	Output current	Serial-OUT		-	+1	mA
I_{OL}	Output current	Serial-OUT		-	-1	mA

Table 6. Recommended operating conditions (continued)

Symbol	Parameter	Test conditions	Min.	Typ.	Max.	Unit
V_{IH}	Input voltage		$0.7 V_{DD}$	-	$V_{DD}+0.3$	V
V_{IL}	Input voltage		-0.3	-	$0.3 V_{DD}$	V
t_{wLAT}	LE/DM1 pulse width	$V_{DD} = 3.0 \text{ V to } 5.0 \text{ V}$	6	-		ns
t_{wCLK}	CLK pulse width		8	-		ns
t_{wEN}	$\overline{OE/DM2}$ pulse width		100	-		ns
$t_{SETUP(D)}$	Setup time for DATA		10	-		ns
$t_{HOLD(D)}$	Hold time for DATA		5	-		ns
$t_{SETUP(L)}$	Setup time for LATCH		10	-		ns
f_{CLK}	Clock frequency	Cascade operation ⁽¹⁾		-	30	MHz

1. If the device is connected in cascade, it may not be possible to achieve the maximum data transfer. Please consider the timings carefully.

3 Electrical characteristics

$V_{DD} = 5V, T_j = -40\text{ °C to }125\text{ °C}$, unless otherwise specified.

Table 7. Electrical characteristics

Symbol	Parameter	Test conditions	Min.	Typ.	Max.	Unit
V_{IH}	Input voltage high level		$0.7 \cdot V_{DD}$		V_{DD}	V
V_{IL}	Input voltage low level		GND		$0.3 \cdot V_{DD}$	
V_{OL}	Serial data output voltage (SDO)	$I_{OL} = +1\text{ mA}$		0.03	0.4	
V_{OH}		$I_{OH} = -1\text{ mA}$	$V_{DD}-0.4$			
I_{OH}	Output leakage current	$V_o = 19\text{ V}, \text{Outn} = \text{OFF}$		0.5	2	μA
ΔI_{OL1}	Current accuracy channel-to-channel ^{(1) (2)}	$V_{DD} = 3.3\text{ V}, V_O = 0.4\text{ V}, R_{ext} = 980\ \Omega$		± 1.5	± 5	%
ΔI_{OL2}		$V_{DD} = 3.3\text{ V}, V_O = 1.3\text{ V}, R_{ext} = 200\ \Omega$		± 1.2	± 4	
ΔI_{OL3}	Current accuracy device-to-device ⁽¹⁾	$V_{DD} = 3.3\text{ V}, V_O = 0.4\text{ V}, R_{ext} = 980\ \Omega$			± 6	
ΔI_{OL4}		$V_{DD} = 3.3\text{ V}, V_O = 1.3\text{ V}, R_{ext} = 200\ \Omega$			± 6	
$R_{IN(up)}$	Pull-up resistor for OE pin		150	300	600	k Ω
$R_{IN(down)}$	Pull-down resistor for LE pin		100	200	400	
IDD(AutoOff)	Supply current (OFF)	$R_{ext} = 980\ \Omega, \text{OE} = \text{low}, \text{OUT0 to OUT7} = \text{OFF}$		200	300	μA
IDD(OFF1)		$R_{ext} = 980\ \Omega, \text{OE} = \text{high}, \text{OUT0 to OUT7} = \text{ON}$		5	8	mA
IDD(OFF2)		$R_{ext} = 200\ \Omega, \text{OE} = \text{high}, \text{OUT0 to OUT15} = \text{ON}$		13	20	
IDD(ON1)	Supply current (ON)	$R_{ext} = 980\ \Omega, \text{OE} = \text{low}, \text{OUT0 to OUT15} = \text{ON}$		6	8	
IDD(ON2)		$R_{ext} = 200\ \Omega, \text{OE} = \text{low}, \text{OUT0 to OUT15} = \text{ON}$		13	20	
Tsd	Thermal shutdown ⁽³⁾			170		$^{\circ}\text{C}$

1. Test performed with all outputs turned on, but only one output loaded at a time.
2. $D_{IOL+} = ((I_{OLmax} - I_{OLmean}) / I_{OLmean}) * 100, D_{IOL-} = ((I_{OLmin} - I_{OLmean}) / I_{OLmean}) * 100$, where $I_{OLmean} = (I_{OLout1} + I_{OLout2} + \dots + I_{OLout16}) / 16$.
3. Not tested, guaranteed by design.



3.1 Switching characteristics

V_{DD} = 5 V, T_j = 25 °C, unless otherwise specified.

Table 8. Switching characteristics⁽¹⁾⁽²⁾

Symbol	Parameter	Test conditions	Min.	Typ.	Max.	Unit
f _{clk}	Clock frequency	Cascade operation			30	MHz
t _{PLH1}	CLK-OUT _n LE\DM1 = H OE\DM2 = L	V _{IH} = V _{DD} V _{IL} = GND CL = 10 pF I _o = 20 mA V _L = 3 V R _{ext} = 1 KΩ RL = 60 Ω	V _{DD} = 3.3 V	40	45	ns
			V _{DD} = 5 V	20	45	
t _{PLH2}	LE\DM1-OUT _n OE\DM2 = L		V _{DD} = 3.3 V	51	80	ns
			V _{DD} = 5 V	32	50	
t _{PLH3}	OE\DM2-OUT _n LE\DM1 = H		V _{DD} = 3.3 V	50	80	ns
			V _{DD} = 5 V	30	50	
t _{PLH}	CLK - SDO		V _{DD} = 3.3 V	22	35	ns
			V _{DD} = 5 V	15	25	
t _{PHL1}	CLK-OUT _n LE\DM1 = H OE\DM2 = L		V _{DD} = 3.3 V	15	25	ns
			V _{DD} = 5 V	12	20	
t _{PHL2}	LE\DM1-OUT _n OE\DM2 = L	V _{DD} = 3.3 V	13	25	ns	
		V _{DD} = 5 V	10	15		
t _{PHL3}	OE\DM2-OUT _n LE\DM1 = H	V _{DD} = 3.3 V	12	20	ns	
		V _{DD} = 5 V	10	15		
t _{PHL}	CLK - SDO	V _{DD} = 3.3 V	25	40	ns	
		V _{DD} = 5 V	18	25		
t _{ON}	Output rise time 10~90 % of voltage waveform	V _{DD} = 3.3 V	35	55	ns	
		V _{DD} = 5 V	10	20		
t _{OFF}	Output fall time 90~10 % of voltage waveform	V _{DD} = 3.3 V	4	10	ns	
		V _{DD} = 5 V	3	8		

Table 8. Switching characteristics⁽¹⁾⁽²⁾

Symbol	Parameter	Test conditions		Min.	Typ.	Max.	Unit
tr	CLK rise time ⁽³⁾					5	µs
tf	CLK fall time ⁽³⁾					5	

1. All table limits are guaranteed by design.
2. Not tested in production.
3. If devices are connected in cascade and tr or tf is large, it may be critical to achieve the timing required for data transfer between two cascaded devices.

4 Equivalent circuit and outputs

Figure 2. OE/DM2 terminal

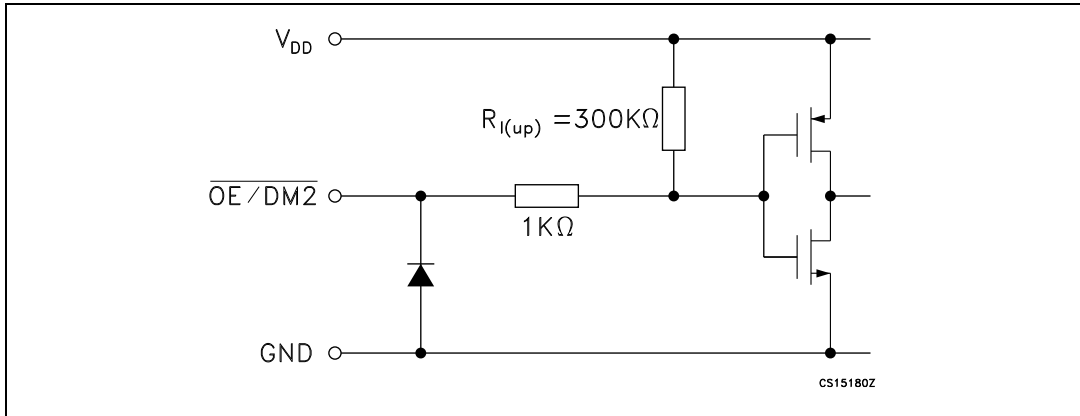

Figure 3. LE/DM1 terminal

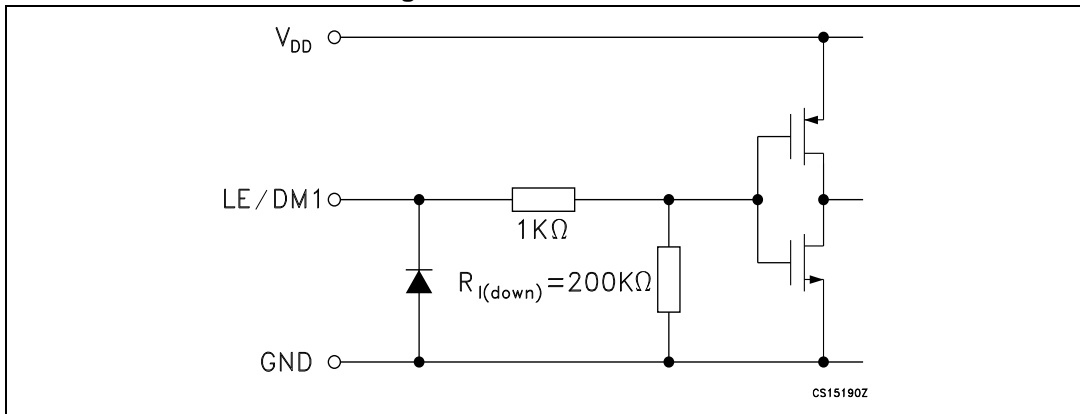

Figure 4. CLK, SDI terminal

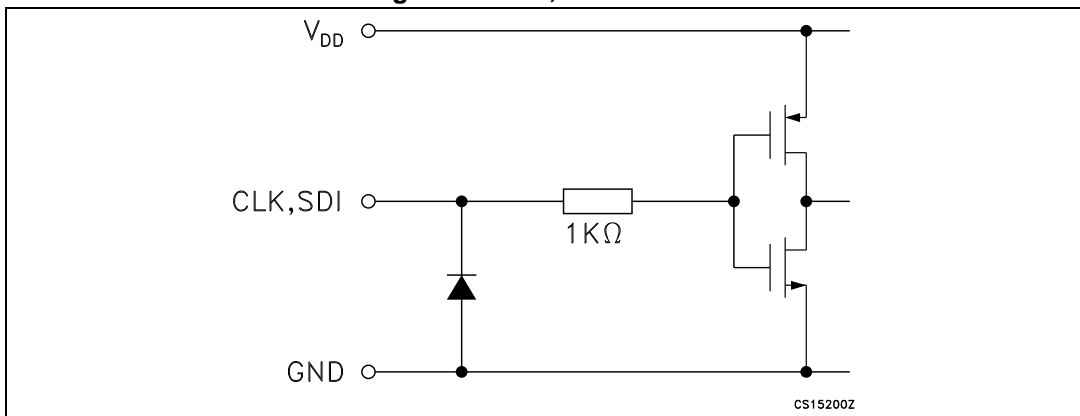

Figure 5. SDO terminal

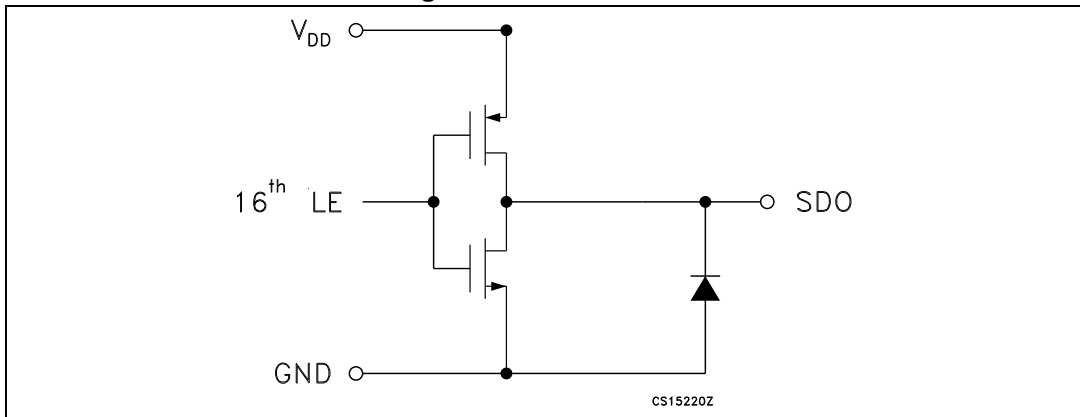
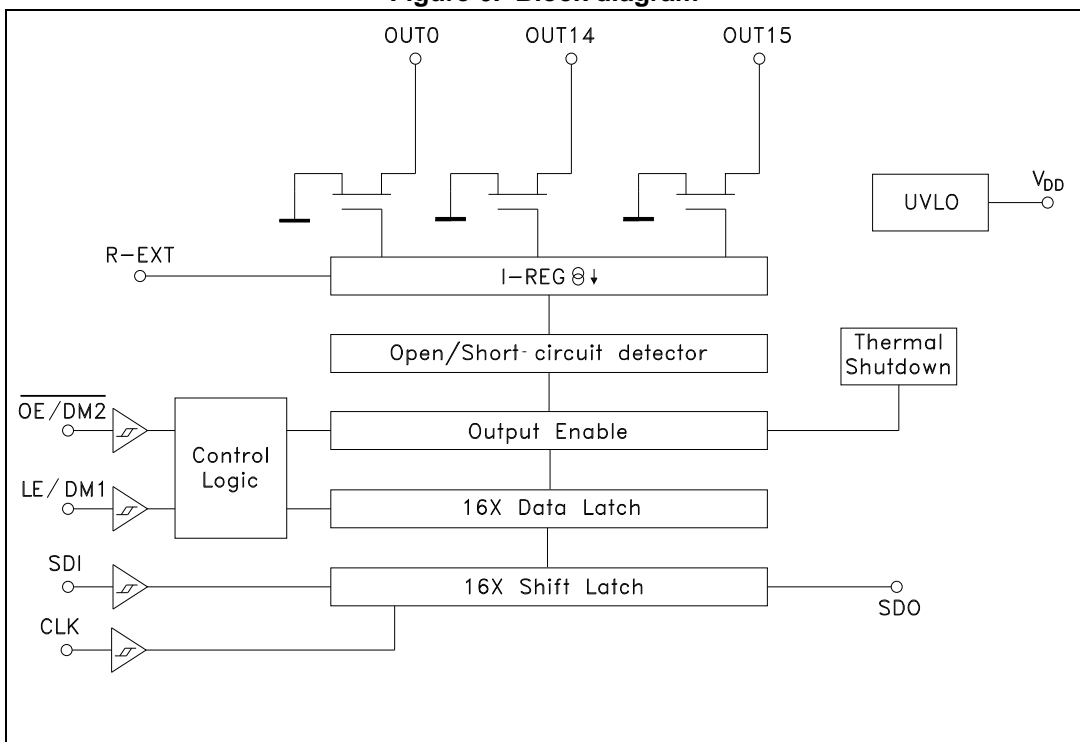

Figure 6. Block diagram



5 Timing diagrams

Table 9. Truth table

Clock	LE/DM1	$\overline{OE/DM2}$	Serial-in	$\overline{OUT0}$ $\overline{OUT7}$ $\overline{OUT15}$	SDO
	H	L	Dn	Dn..... Dn - 7..... Dn -15	Dn - 15
	L	L	Dn + 1	No change	Dn - 14
	H	L	Dn + 2	Dn + 2..... Dn - 5..... Dn -13	Dn - 13
	X	L	Dn + 3	Dn + 2..... Dn - 5..... Dn -13	Dn - 13
	X	H	Dn + 3	OFF	Dn - 13

Note: $OUTn = ON$ when $Dn = H$ $OUTn = OFF$ when $Dn = L$.

Figure 7. Timing diagram

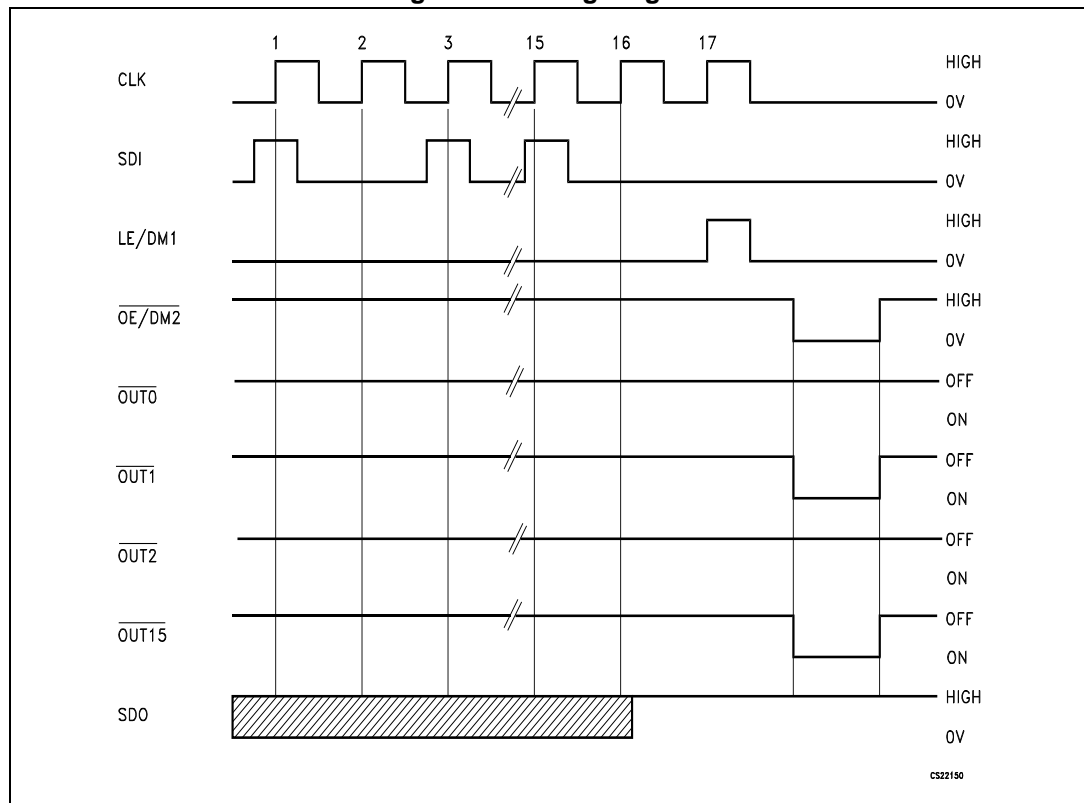

Note: Latch and output enable are level-sensitive and they are not synchronized with rising or falling edge of CLK signal. When LE/DM1 terminal is low level, the latch circuits hold the previous set of data. When LE/DM1 terminal is high level, the latch circuits refresh new set of data from SDI chain. When $\overline{OE/DM2}$ terminal is at low level, the output terminals - Out0 to Out15 respond to data in the latch circuits, either '1' ON or '0' OFF. When $\overline{OE/DM2}$ terminal is at high level, all output terminals are switched OFF.

Figure 8. Clock, serial-in, serial-out

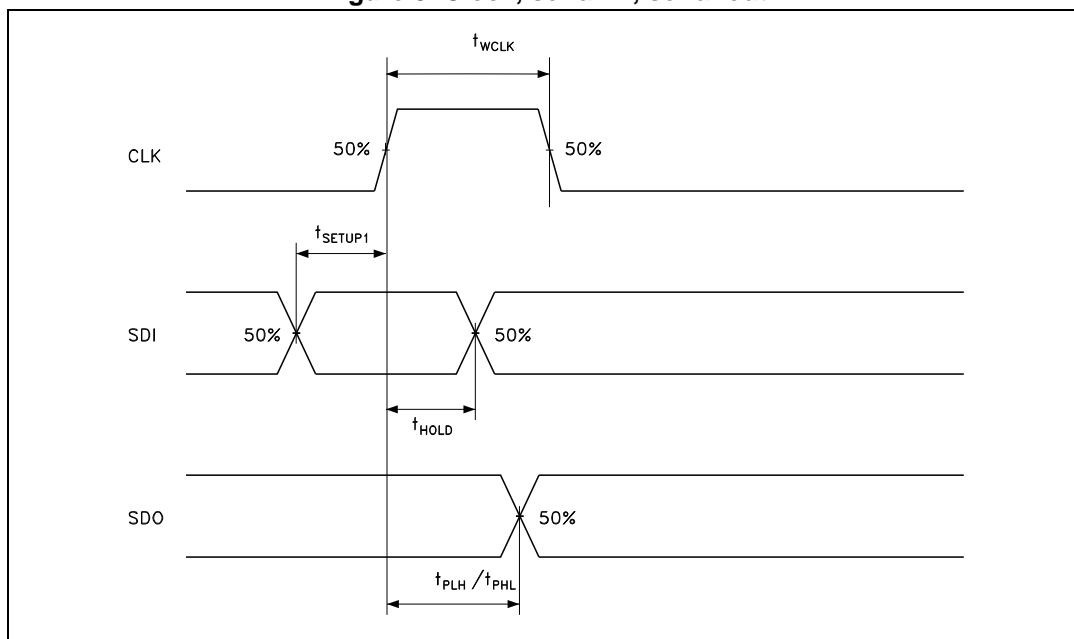

Figure 9. Clock, serial-in, latch, enable, outputs

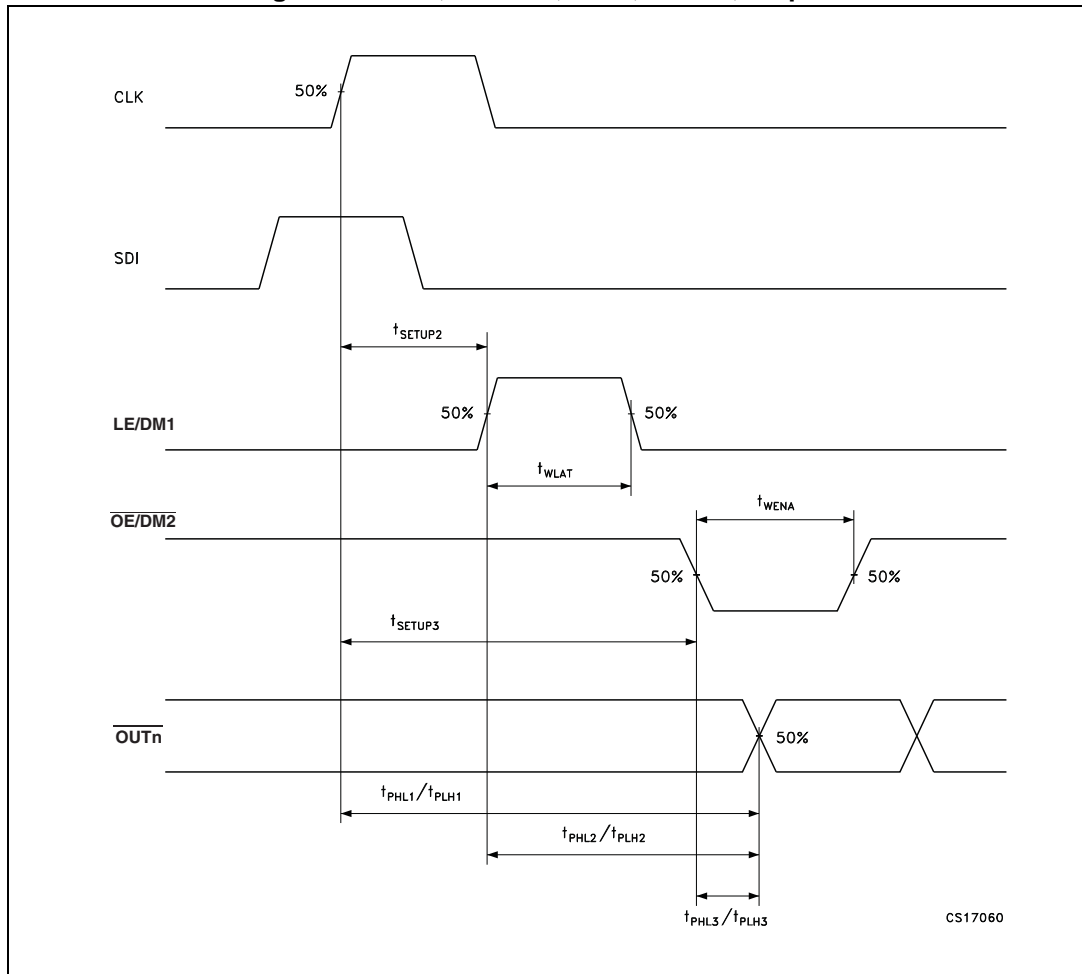
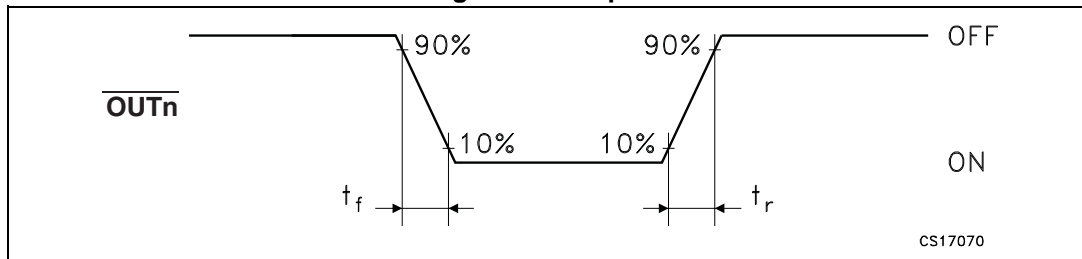
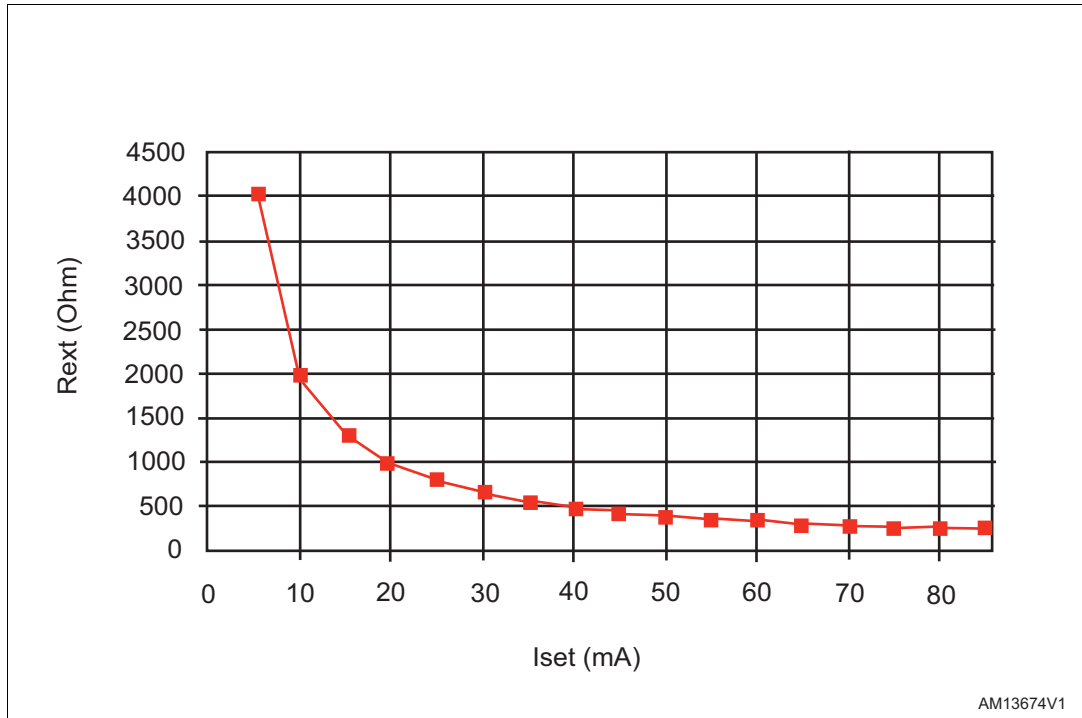

Figure 10. Outputs



6 Typical characteristics

Figure 11. Output current- R_{EXT} resistor



AM13674V1

Table 10. Output current- R_{EXT} resistor

$R_{EXT}(\Omega)$	Output current (mA)
976	20
780	25
652	30
560	35
488	40
433	45
389	50
354	55
325	60
300	65
278	70
259	75
241	80
229	85

Conditions:

- Temperature = 25 °C, $V_{DD} = 3.3\text{ V}; 5.0\text{ V}$, $I_{SET} = 3\text{ mA}; 5\text{ mA}; 10\text{ mA}; 20\text{ mA}; 50\text{ mA}; 80\text{ mA}$.

Figure 12. I_{SET} vs. dropout voltage (V_{drop})

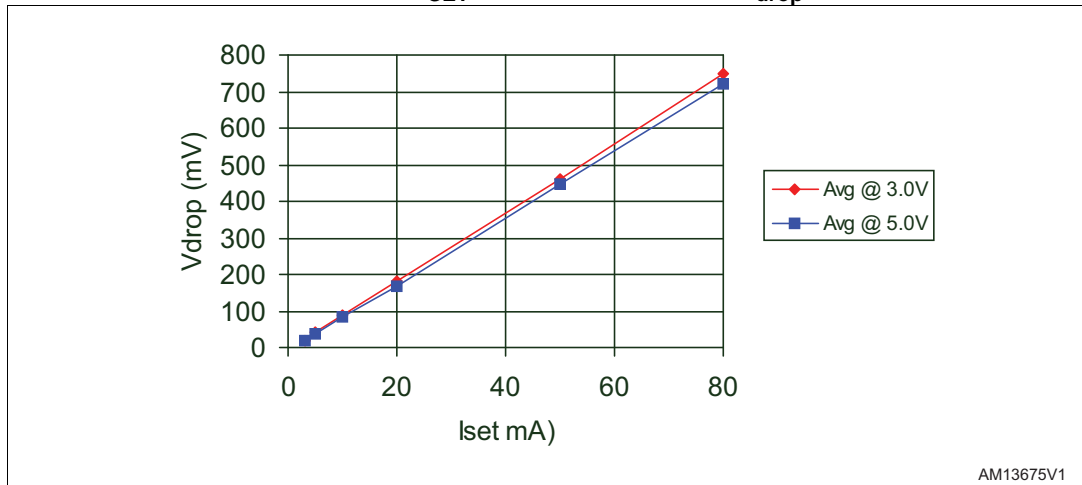
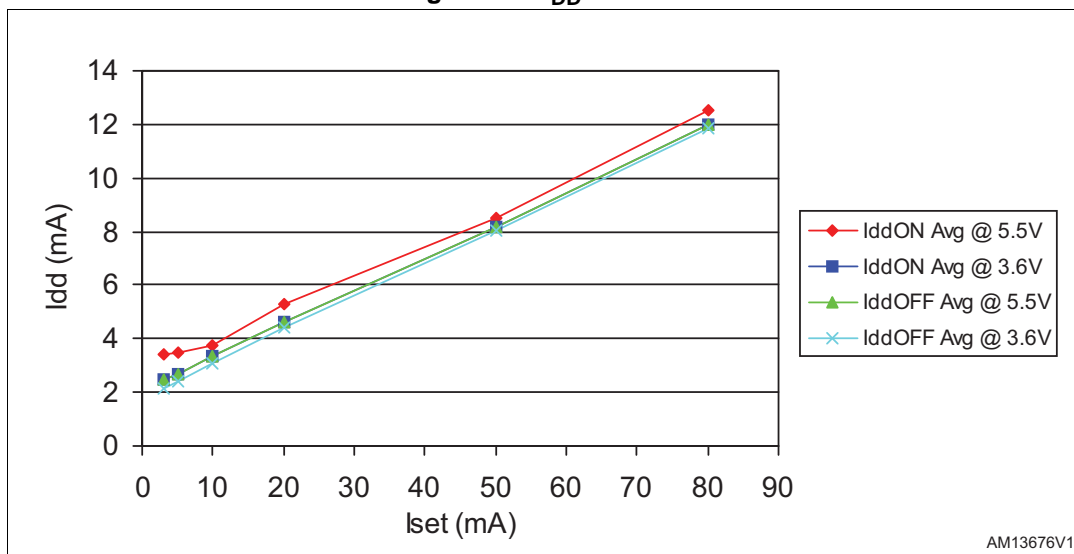

Table 11. I_{SET} vs. dropout voltage (V_{drop})

I_{out} (mA)	Avg @ 3.0 V	Avg @ 5.0 V
3	19.33	22.66
5	36.67	40.33
10	77.33	80
20	158.67	157.33
50	406	406
80	692	668

Figure 13. I_{DD} ON/OFF



7 Detection mode functionality

7.1 Phase one: “entering in detection mode“

From the “normal mode” condition the device can switch to the “error mode” by a logic sequence on the $\overline{OE}/DM2$ and $LE/DM1$ pins as shown in the following table and diagram:

Table 12. Entering in detection truth table

CLK	1°	2°	3°	4°	5°
$\overline{OE}/DM2$	H	L	H	H	H
$LE/DM1$	L	L	L	H	L

Figure 14. Entering in detection timing diagram

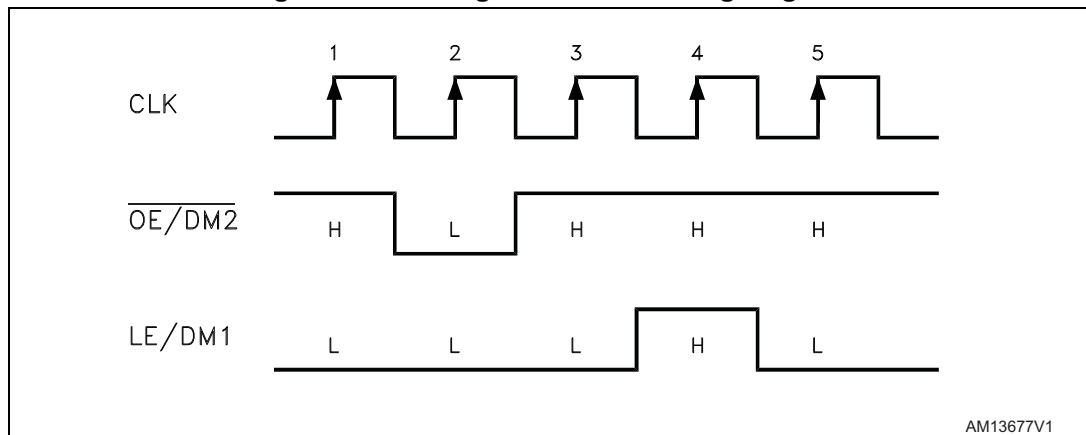

After these five CLK cycles the device goes into the “error detection mode” and at the 6th rising edge of CLK the SDI data are ready for sampling.

7.2 Phase two: “error detection”

The 16 data bits must be set to “1” in order to set ON all the outputs during the detection. The data are latched by LE/DM1 and after that the outputs are ready for the detection process. When the microcontroller switches the OE/DM2 to LOW, the device drives the LEDs in order to analyze if an OPEN or SHORT condition has occurred.

Figure 15. Detection diagram

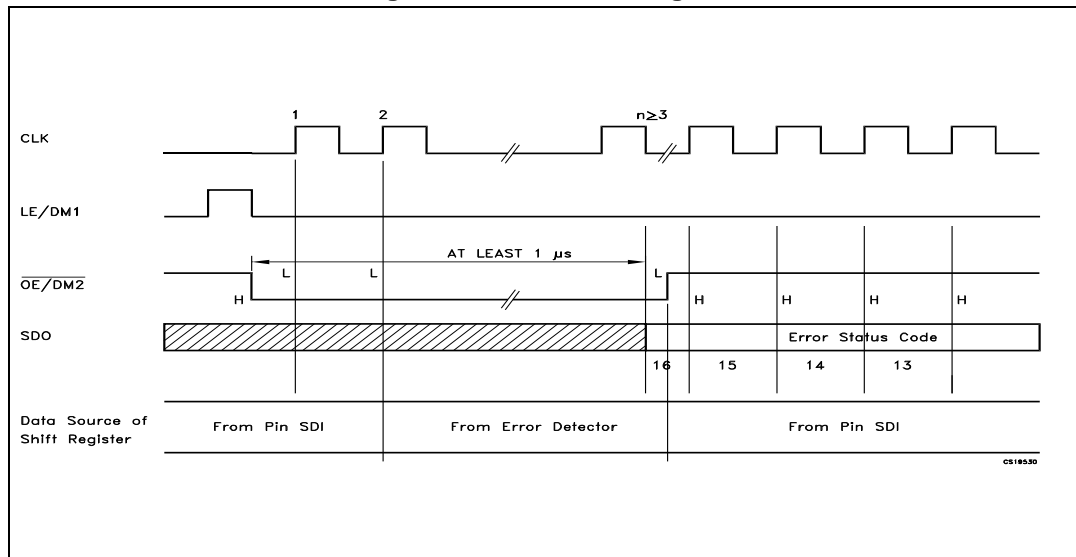

The LED status is detected at least in 1 microsecond (minimum) and after this time the microcontroller sets OE/DM2 in high state and the output data detection result goes to the microprocessor via SDO.

Detection mode and normal mode both use the same data format. As soon as all the detection data bits are available on the serial line, the device may go back to normal mode of operation. To re-detect the status, the device must go back in normal mode and re-enter error detection mode.

Figure 16. Timing example for open and/or short detection

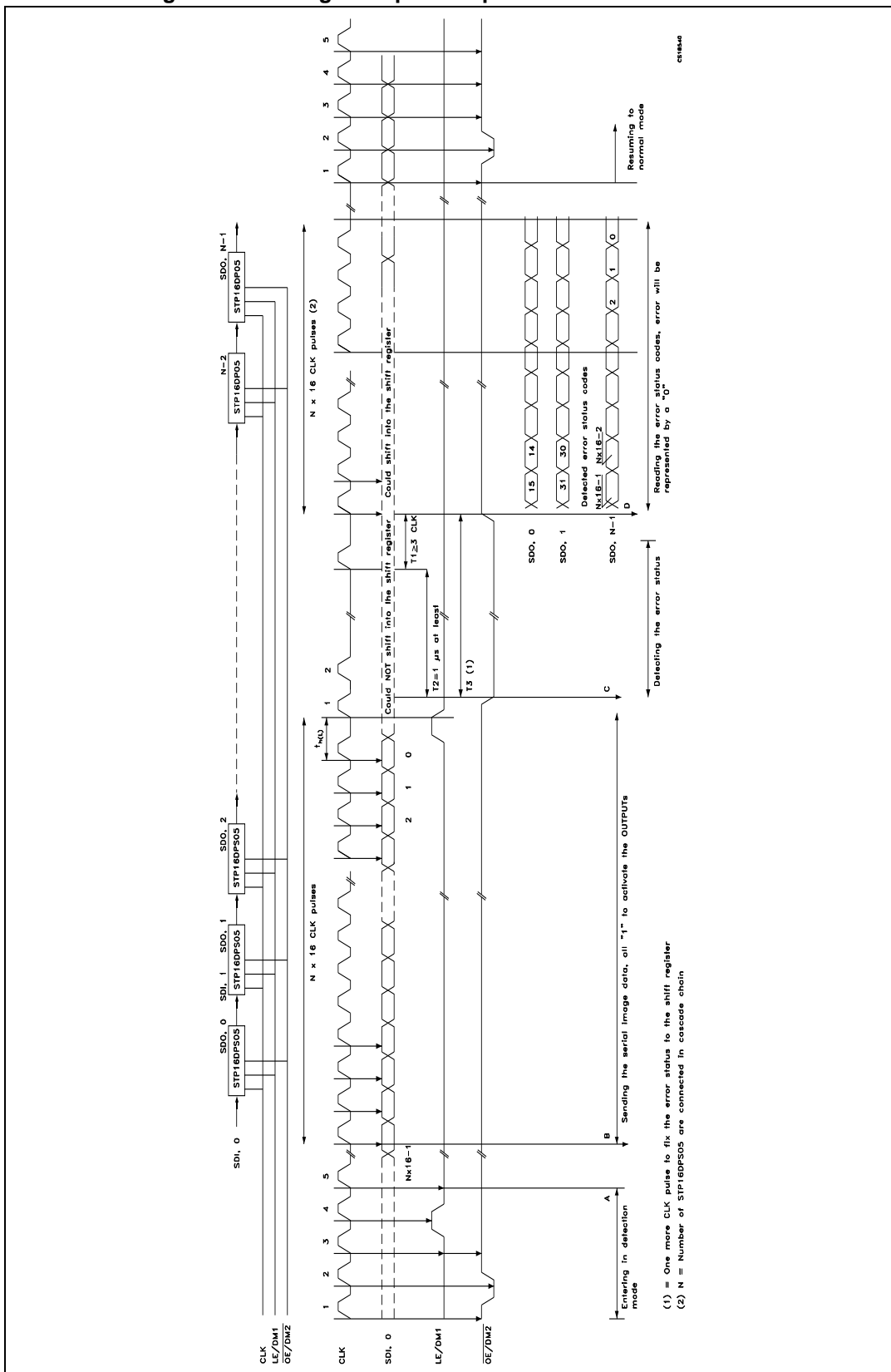

7.3 Phase three: “resuming to normal mode”

The sequence for re-entering in normal mode is shown in the following table and diagram:

Figure 17. Resuming to normal mode timing diagram

CLK	1°	2°	3°	4°	5°
$\overline{\text{OE/DM2}}$	H	L	H	H	H
LE/DM1	L	L	L	L	L

Note: For proper device operation the “entering in detection” sequence must be followed by a “resume mode” sequence, it is not possible to insert consecutive equal sequences.

7.4 Error detection conditions

$V_{DD} = 3.3$ to 5 V temperature range -40 to 125 °C

Table 13. Detection conditions

Configuration	Detection mode	Detection results		
SW-1 or SW-3b	Open line or output short to GND detected	$\implies I_{ODEC} \leq 0.5 \times I_O$	No error detected	$\implies I_{ODEC} \geq 0.5 \times I_O$
SW-2 or SW-3a	Short on LED or short to V-LED detected	$\implies V_O \geq 2.4 \text{ V}$	No error detected	$\implies V_O \leq 2.2 \text{ V}$

Note: Where: I_O = the output current programmed by the R_{EXT} , I_{ODEC} = the detected output current in detection mode.

Figure 18. Detection circuit

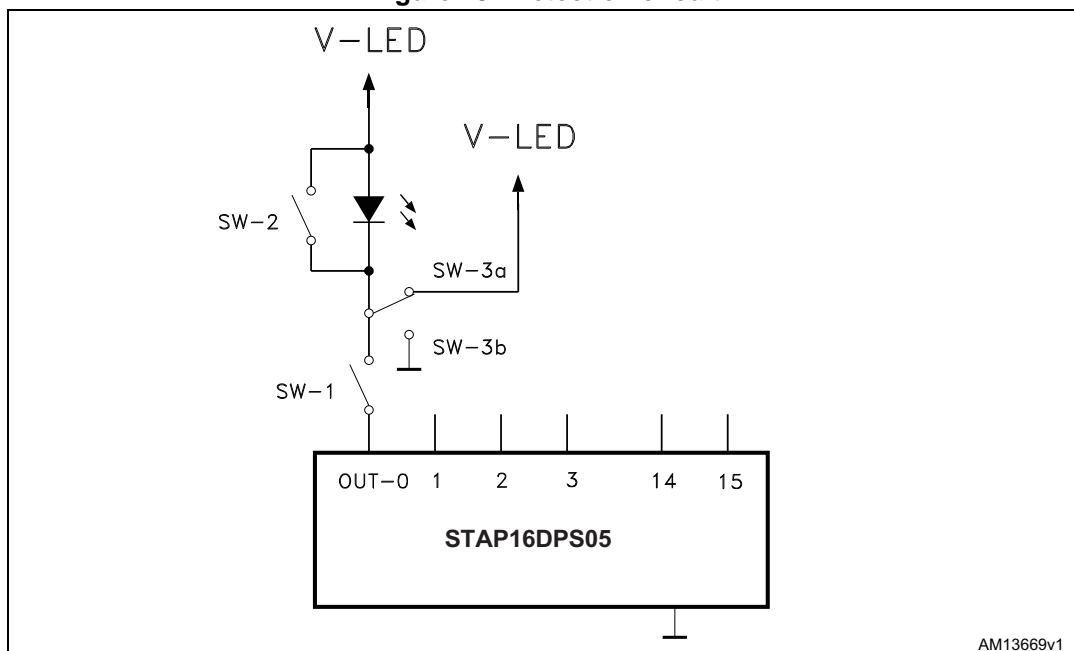

AM13669v1

Figure 19. Error detection sequence

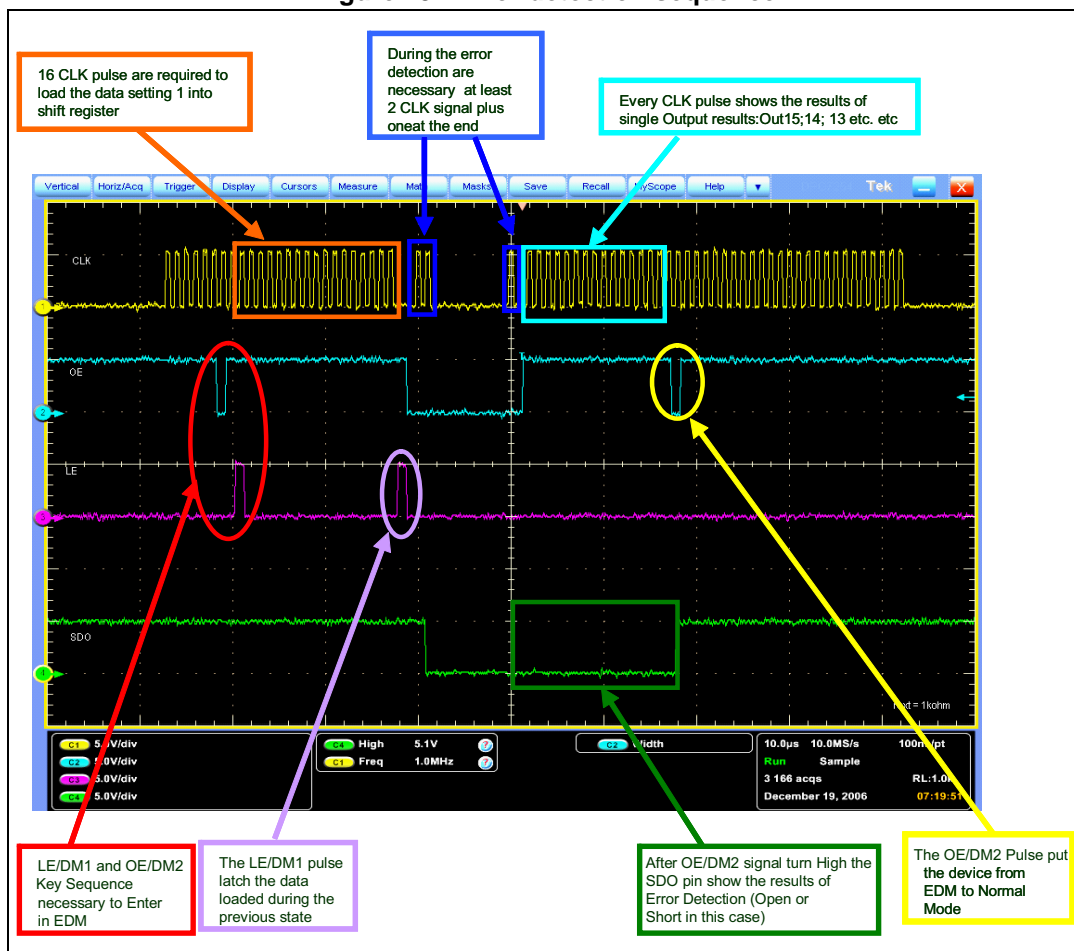

Typical schematic used to perform the error detection:

Figure 20. Error detection typical schematic

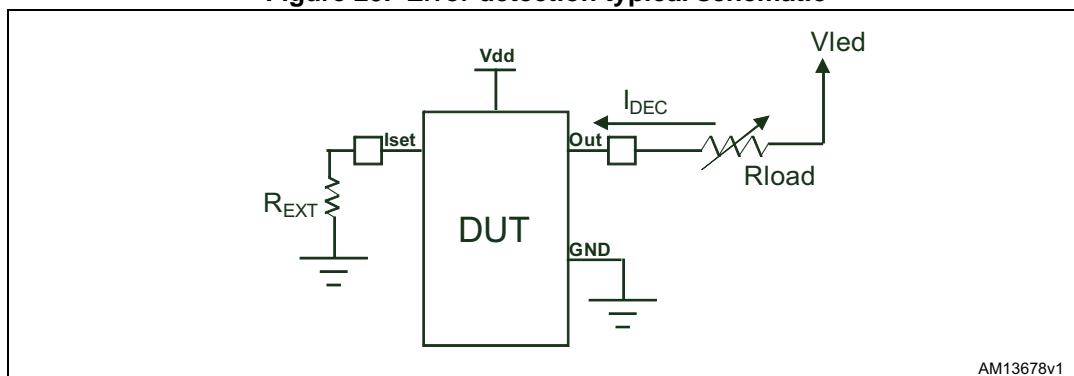

I_{ODEC} can be measured as follows:

$$I_{ODEC} = (V_{led} - V_{load}) / R_{load}$$

Table 14 and Table 15 show respectively the I_{ODEC} average value at 3.3 V and 5.0 V.

The I_{ODEC} is the current value recognized by the device output open error detection.

Table 14. I_{ODEC} average value at 3.3 V

Vdd (V)	Iset (mA)	R _{EXT} (Ω)	Iout AVG (mA)
3.3	5	4270	2.097
	10	2056	6.79
	20	1006	10.46
	50	382	26.92
	80	251	35.03

Table 15. I_{ODEC} average value at 5 V

Vdd (V)	Iset (mA)	R _{EXT} (Ω)	Iout AVG (mA)
5	5	4270	1.98
	10	2056	6.09
	20	1006	9.67
	50	382	25.54
	80	251	38.9

7.5 Auto power-saving

The auto power-saving feature minimizes the quiescent current if no active data is detected on the latches and auto powers-up the device as the first active data is latched.

Figure 21. Auto power-saving feature

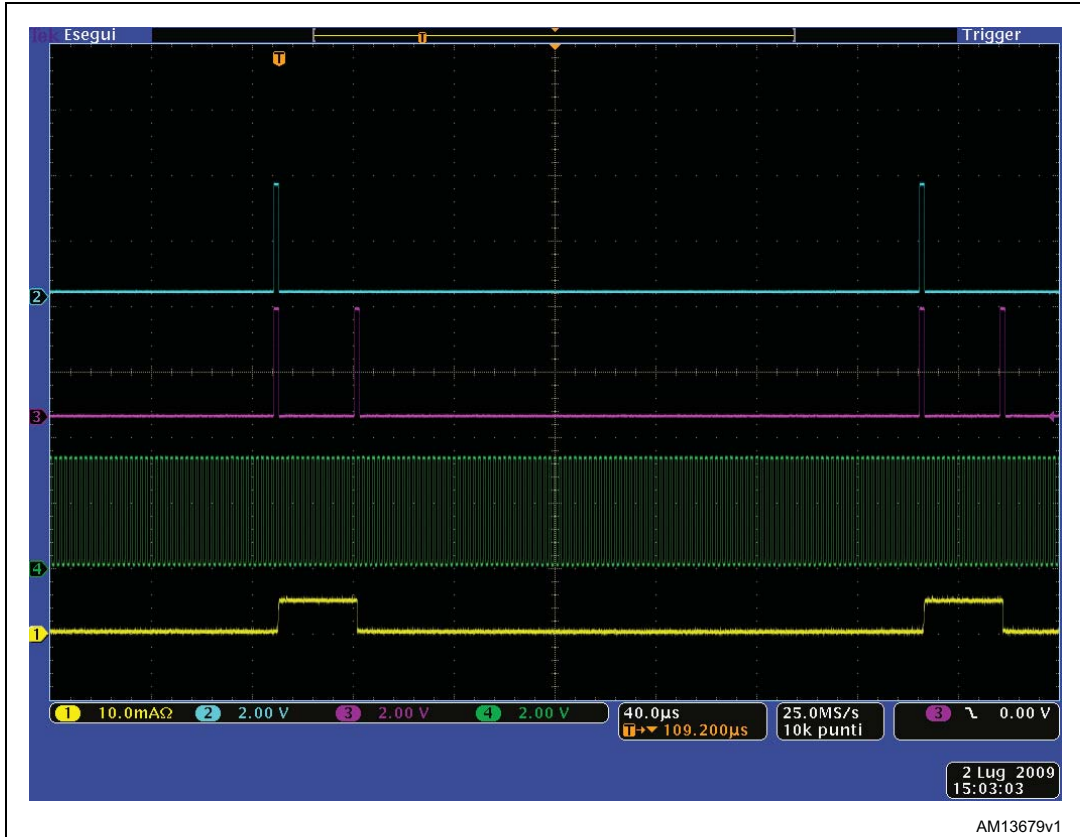

Conditions:

- Temp. = 25 °C, $V_{DD} = 3.3\text{ V}$, $V_{in} = V_{DD}$, $V_{Led} = 3.0\text{ V}$, $I_{set} = 20\text{ mA}$
- Ch1 (yellow) = I_{DD} , Ch2 (blue) = SDI, Ch3 (purple) = LE/DM1, Ch4 (green) = CLK

I_{dd} consumption:

- I_{dd} (normal operation) = 5.15 mA
- I_{dd} (shutdown condition) = 163 μA

Figure 22. Delay LE-OUT

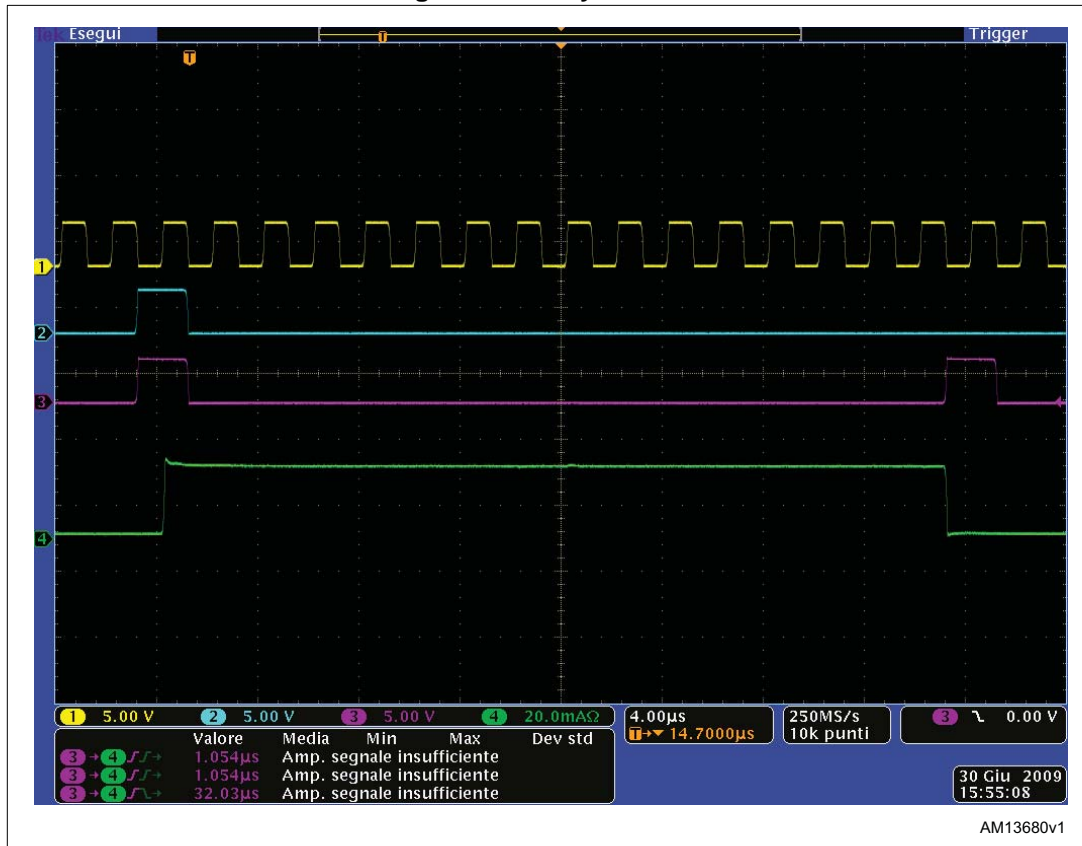

After 16 clock cycles without data change, the auto power-saving mode starts as expected. Delay TLE-OUT = 1.053 μs

Conditions:

- Temp. = 25 °C, V_{DD} = 3.3 V, V_{in} = V_{DD}, V_{Led} = 3.0 V, I_{set} = 20 mA
- Ch1 (yellow) = CLK, Ch2 (blue) = SDI, Ch3 (purple) = LE/DM1, Ch4 (green) = IOUT

Figure 23. Auto power-saving behavior



Note: When the device goes from auto power-saving to normal operating condition, the first output switching ON shows the T_{ON} condition as seen in the plot above.
 Temp. = 25°C, V_{DD} = 3.3 V, V_{in} = V_{DD} , V_{Led} = 3.0 V, I_{set} = 20 mA
 Ch1 (yellow) = I_{DD} , Ch2 (blue) = SDI, Ch3 (purple) = LE/DM1, Ch4 (green) = CLK.

8 Package mechanical data

In order to meet environmental requirements, ST offers these devices in different grades of ECOPACK® packages, depending on their level of environmental compliance. ECOPACK® specifications, grade definitions and product status are available at: www.st.com. ECOPACK® is an ST trademark.

Figure 24. TSSOP24 exposed pad dimensions

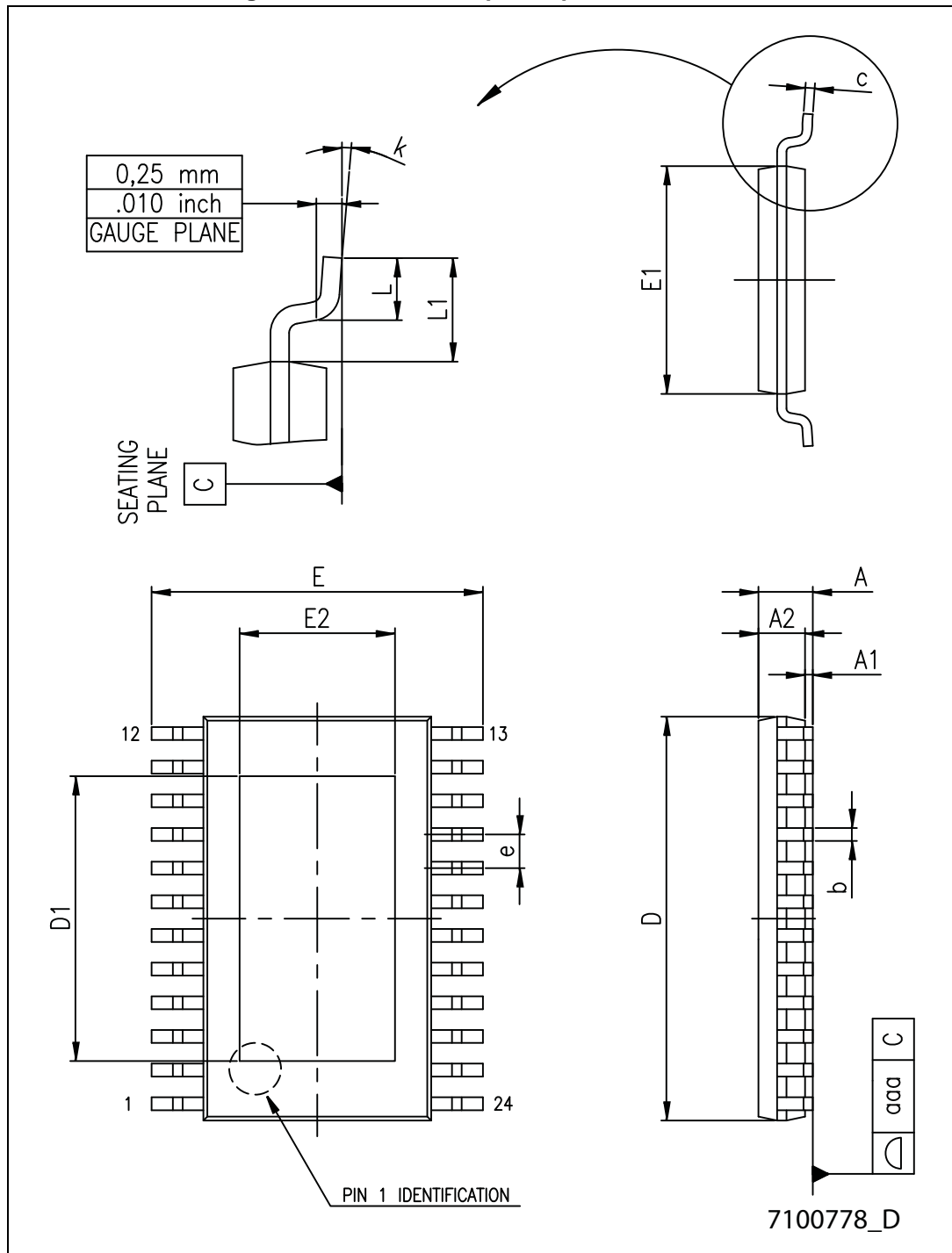

Table 16. TSSOP24 exposed pad mechanical data

Symbol	mm		
	Min.	Typ.	Max.
A			1.20
A1			0.15
A2	0.80	1.00	1.05
b	0.19		0.30
c	0.09		0.20
D	7.70	7.80	7.90
D1	4.80	5.00	5.2
E	6.20	6.40	6.60
E1	4.30	4.40	4.50
E2	3.00	3.20	3.40
e		0.65	
L	0.45	0.60	0.75
L1		1.00	
k	0		8
aaa			0.10

9 Packaging mechanical data

Figure 25. TSSOP24 exposed pad tape and reel dimensions

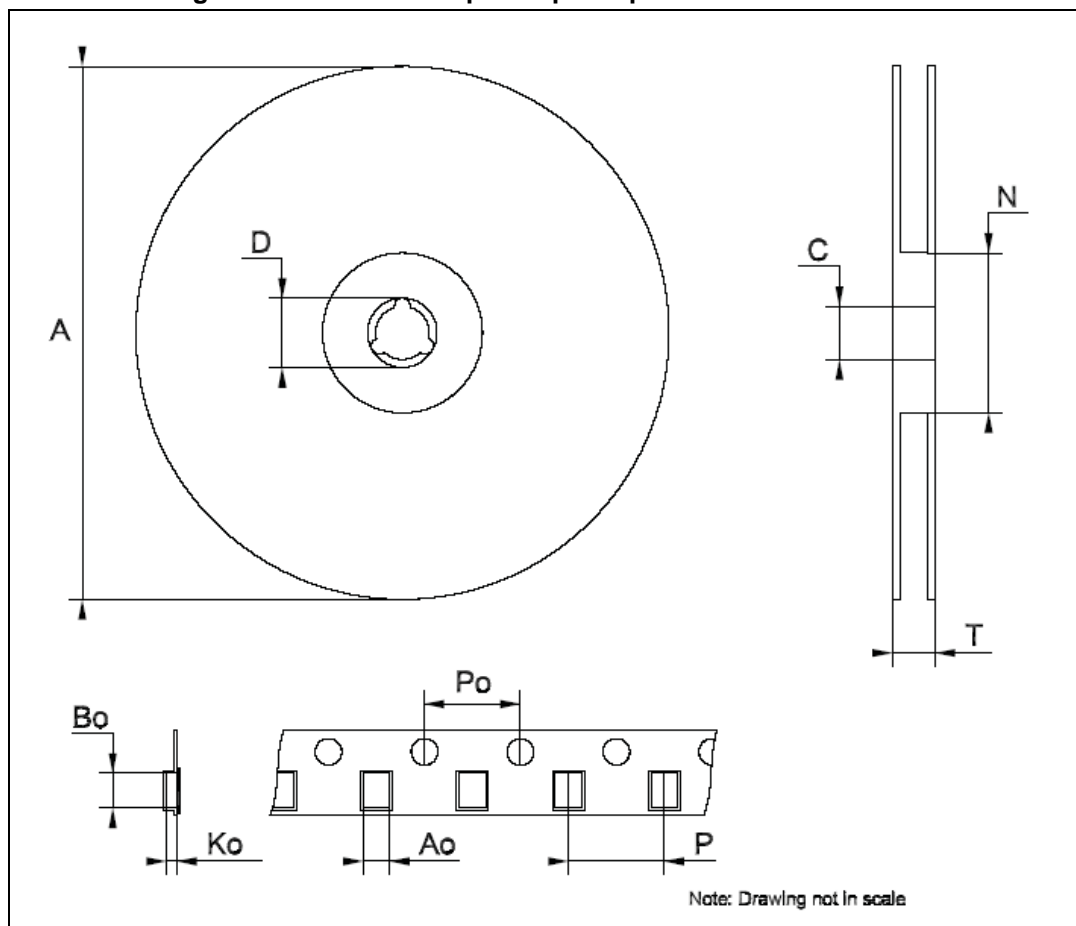

Table 17. Tape and reel TSSOP24 exposed pad

Dim.	mm		
	Min.	Typ.	Max.
A			330
C	12.8		13.2
D	20.2		
N	60		
T			22.4
Ao	6.8		7
Bo	8.2		8.4
Ko	1.7		1.9
Po	3.9		4.1
P	11.9		12.1

10 Revision history

Table 18. Document revision history

Date	Revision	Changes
21-May-2013	1	Initial release.
01-Jul-2013	2	Added footnote in Table 8: Switching characteristics .
11-Oct-2013	3	Modified T _{OPR} value in Table 4: Absolute maximum ratings .
10-Mar-2014	4	Modified footnote 1 in Table 8: Switching characteristics . Added footnote 2 in Table 8: Switching characteristics . Updated Table 3: Pin description .
05-Jun-2014	5	Updated Table 16: TSSOP24 exposed pad mechanical data . Minor text changes.

Please Read Carefully:

Information in this document is provided solely in connection with ST products. STMicroelectronics NV and its subsidiaries ("ST") reserve the right to make changes, corrections, modifications or improvements, to this document, and the products and services described herein at any time, without notice.

All ST products are sold pursuant to ST's terms and conditions of sale.

Purchasers are solely responsible for the choice, selection and use of the ST products and services described herein, and ST assumes no liability whatsoever relating to the choice, selection or use of the ST products and services described herein.

No license, express or implied, by estoppel or otherwise, to any intellectual property rights is granted under this document. If any part of this document refers to any third party products or services it shall not be deemed a license grant by ST for the use of such third party products or services, or any intellectual property contained therein or considered as a warranty covering the use in any manner whatsoever of such third party products or services or any intellectual property contained therein.

UNLESS OTHERWISE SET FORTH IN ST'S TERMS AND CONDITIONS OF SALE ST DISCLAIMS ANY EXPRESS OR IMPLIED WARRANTY WITH RESPECT TO THE USE AND/OR SALE OF ST PRODUCTS INCLUDING WITHOUT LIMITATION IMPLIED WARRANTIES OF MERCHANTABILITY, FITNESS FOR A PARTICULAR PURPOSE (AND THEIR EQUIVALENTS UNDER THE LAWS OF ANY JURISDICTION), OR INFRINGEMENT OF ANY PATENT, COPYRIGHT OR OTHER INTELLECTUAL PROPERTY RIGHT.

ST PRODUCTS ARE NOT DESIGNED OR AUTHORIZED FOR USE IN: (A) SAFETY CRITICAL APPLICATIONS SUCH AS LIFE SUPPORTING, ACTIVE IMPLANTED DEVICES OR SYSTEMS WITH PRODUCT FUNCTIONAL SAFETY REQUIREMENTS; (B) AERONAUTIC APPLICATIONS; (C) AUTOMOTIVE APPLICATIONS OR ENVIRONMENTS, AND/OR (D) AEROSPACE APPLICATIONS OR ENVIRONMENTS. WHERE ST PRODUCTS ARE NOT DESIGNED FOR SUCH USE, THE PURCHASER SHALL USE PRODUCTS AT PURCHASER'S SOLE RISK, EVEN IF ST HAS BEEN INFORMED IN WRITING OF SUCH USAGE, UNLESS A PRODUCT IS EXPRESSLY DESIGNATED BY ST AS BEING INTENDED FOR "AUTOMOTIVE, AUTOMOTIVE SAFETY OR MEDICAL" INDUSTRY DOMAINS ACCORDING TO ST PRODUCT DESIGN SPECIFICATIONS. PRODUCTS FORMALLY ESCC, QML OR JAN QUALIFIED ARE DEEMED SUITABLE FOR USE IN AEROSPACE BY THE CORRESPONDING GOVERNMENTAL AGENCY.

Resale of ST products with provisions different from the statements and/or technical features set forth in this document shall immediately void any warranty granted by ST for the ST product or service described herein and shall not create or extend in any manner whatsoever, any liability of ST.

ST and the ST logo are trademarks or registered trademarks of ST in various countries.

Information in this document supersedes and replaces all information previously supplied.

The ST logo is a registered trademark of STMicroelectronics. All other names are the property of their respective owners.

© 2014 STMicroelectronics - All rights reserved

STMicroelectronics group of companies

Australia - Belgium - Brazil - Canada - China - Czech Republic - Finland - France - Germany - Hong Kong - India - Israel - Italy - Japan - Malaysia - Malta - Morocco - Philippines - Singapore - Spain - Sweden - Switzerland - United Kingdom - United States of America

www.st.com