

Common mode filter with ESD protection for MHL/USB2.0/USB3.0 interface

Datasheet - production data

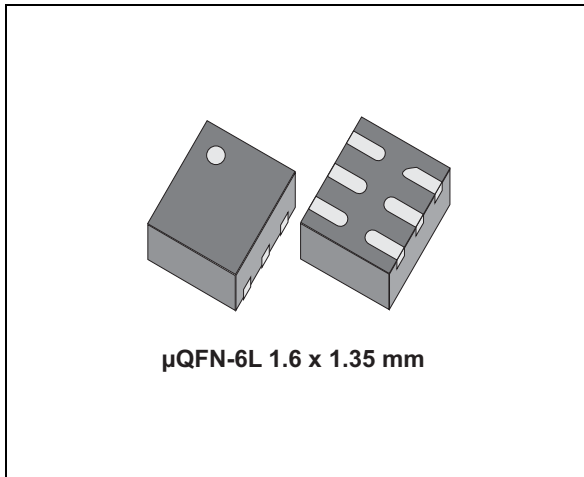
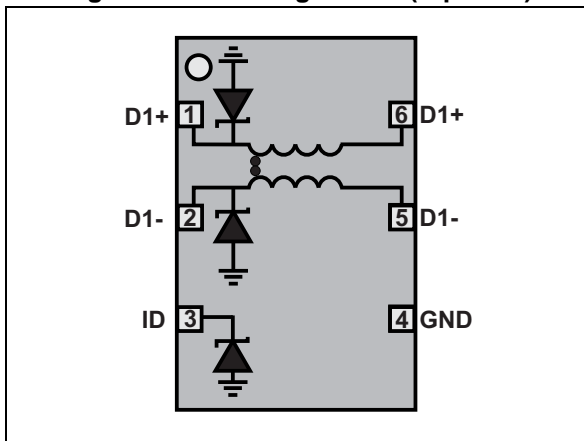

Figure 1. Pin configuration (top view)



Features

- Provides -20 dB attenuation at 700 MHz in LTE bands
- High common mode attenuation:
 - -25 dB at 800 MHz
 - -10 dB at 2GHz
- Very low PCB space consumption
- Thin package: 0.55 mm max.
- Lead-free package
- High reduction of parasitic elements through integration.

Complies with the following standards:

- IEC 61000-4-2 level 4:
 - ±15 kV (air discharge)
 - ±8 kV (contact discharge)

Applications

- Mobile phones
- Notebook, laptop
- Portable devices
- PND

Description

This device is a highly integrated common mode filter designed to suppress EMI/RFI common mode noise on high speed differential serial buses and complies with the MHL standard. The device can protect and filter a single differential lane.

1 Characteristics

Table 1. Absolute maximum ratings ($T_{amb} = 25\text{ }^{\circ}\text{C}$)

Symbol	Parameter		Value	Unit
V_{PP}	Peak pulse voltage	IEC 61000-4-2		
		Contact discharge (connector side)	8	kV
		Air discharge (connector side)	16	
I_{DC}	Maximum DC current		100	mA
T_{op}	Operating temperature range		-40 to +85	$^{\circ}\text{C}$
T_j	Maximum junction temperature		125	$^{\circ}\text{C}$
T_{stg}	Storage temperature range		- 55 to +150	$^{\circ}\text{C}$

Figure 2. Electrical characteristics (definitions)

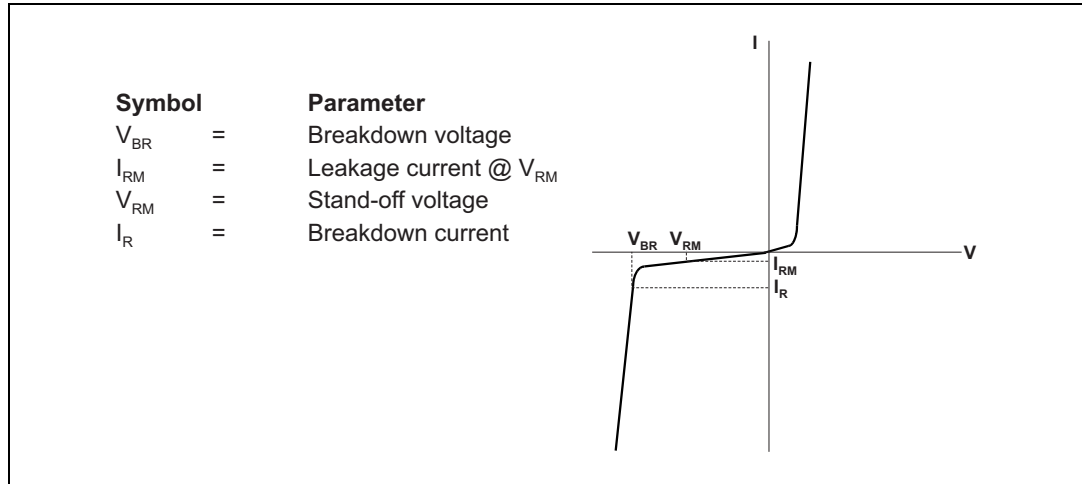

Table 2. Electrical characteristics ($T_{amb} = 25\text{ }^{\circ}\text{C}$)

Symbol	Test conditions	Min.	Typ.	Max.	Unit
V_{BR}	$I_R = 1\text{ mA}$	6			V
I_{RM}	$V_{RM} = 3\text{ V per line}$			100	nA
R_{DC}	DC serial resistance		5		Ω

Figure 3. Differential attenuation versus frequency ($Z_{0\text{ diff}} = 100 \Omega$)

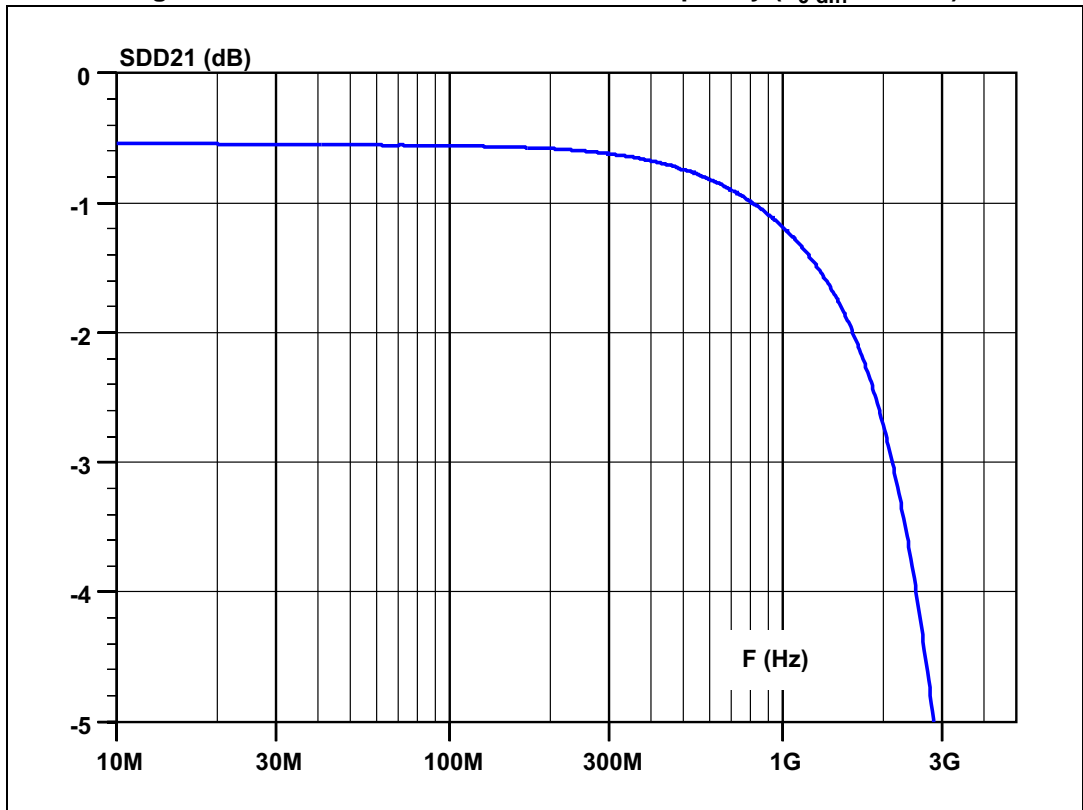

Figure 4. Common mode attenuation versus frequency ($Z_{0\text{ com}} = 50 \Omega$)

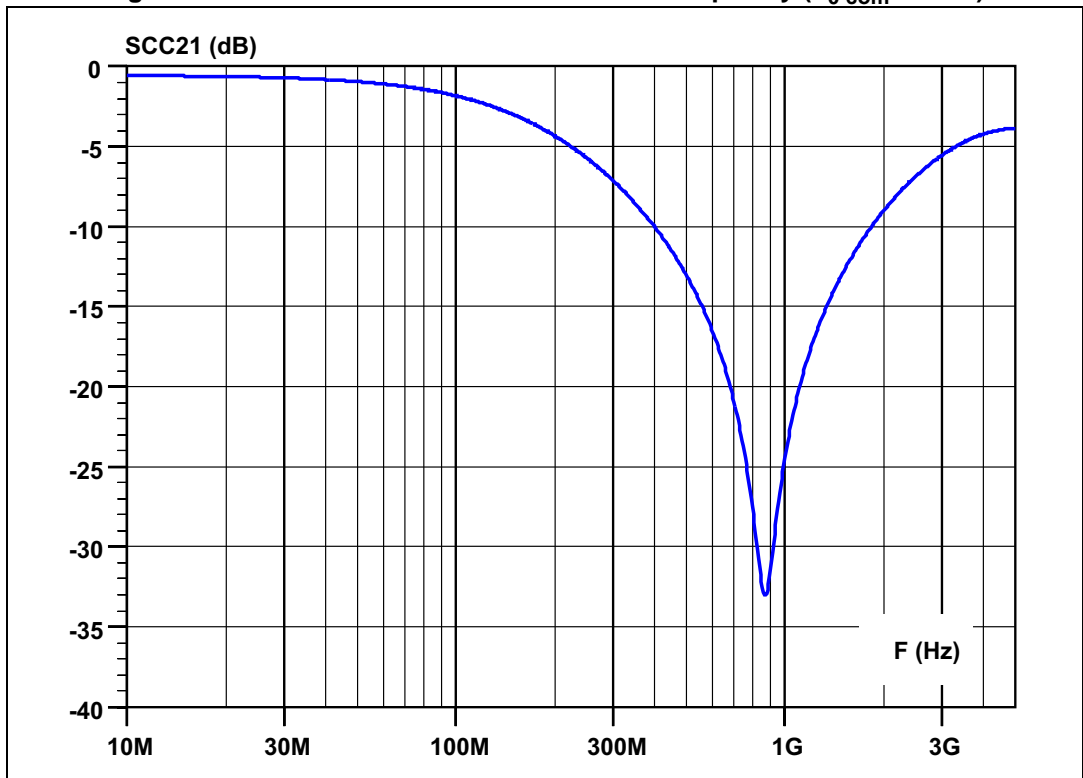

Figure 5. Return loss versus frequency ($Z_{0\text{ com}} = 50 \Omega$)

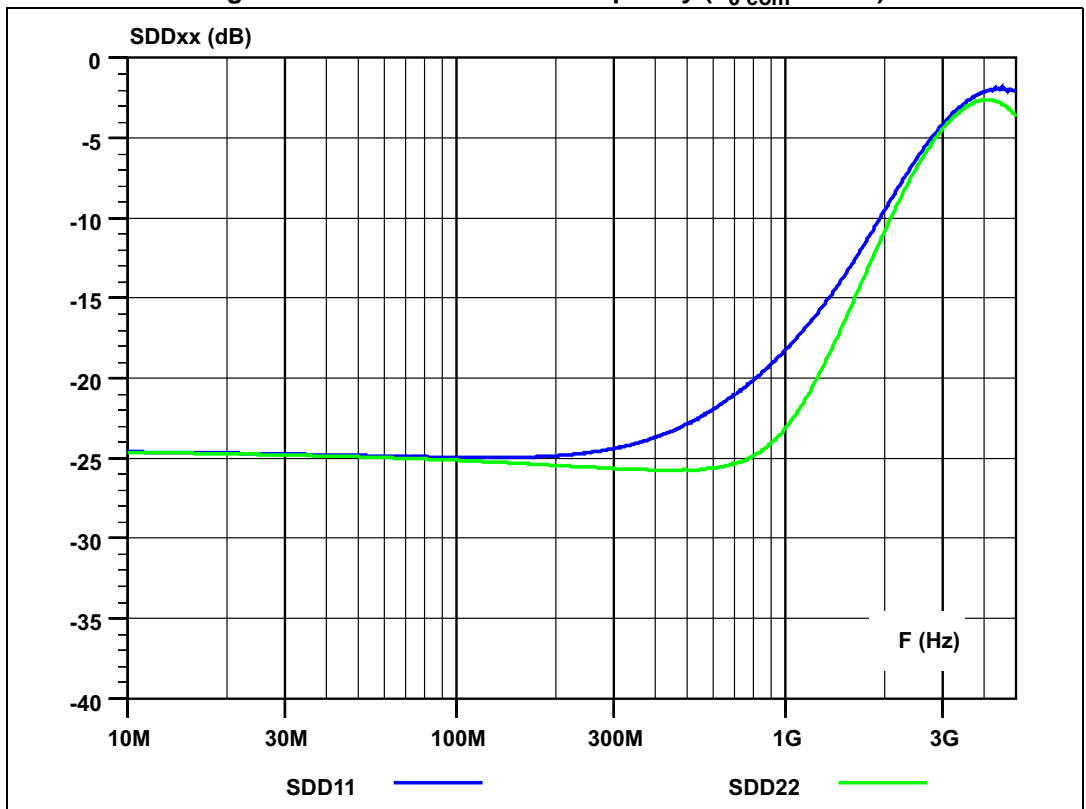

Figure 6. ESD response to IEC61000-4-2 (+8 kV contact discharge) on data lane

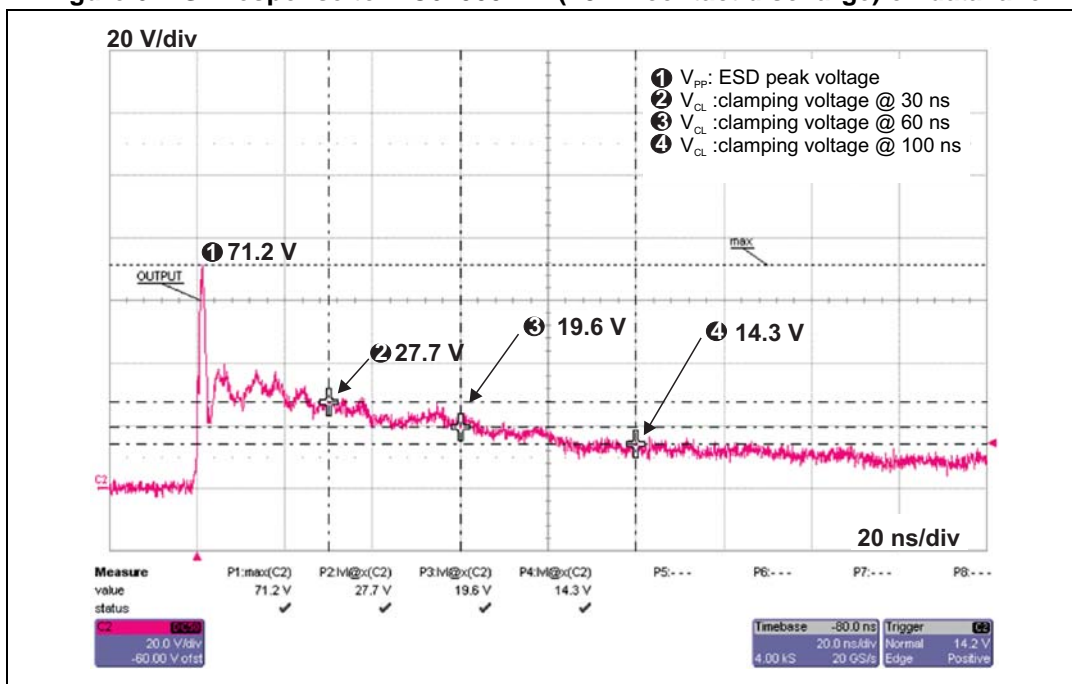

Figure 7. ESD response to IEC61000-4-2 (-8 kV contact discharge) on data lane

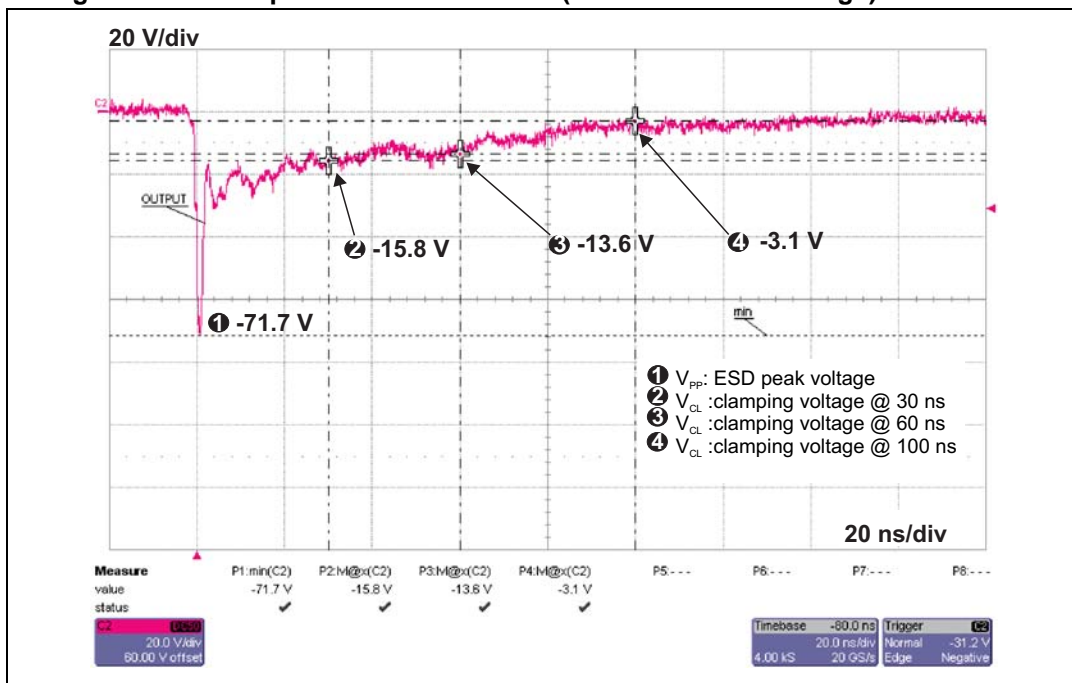

Figure 8. ESD response to IEC61000-4-2 (+8 kV contact discharge) on ID pin

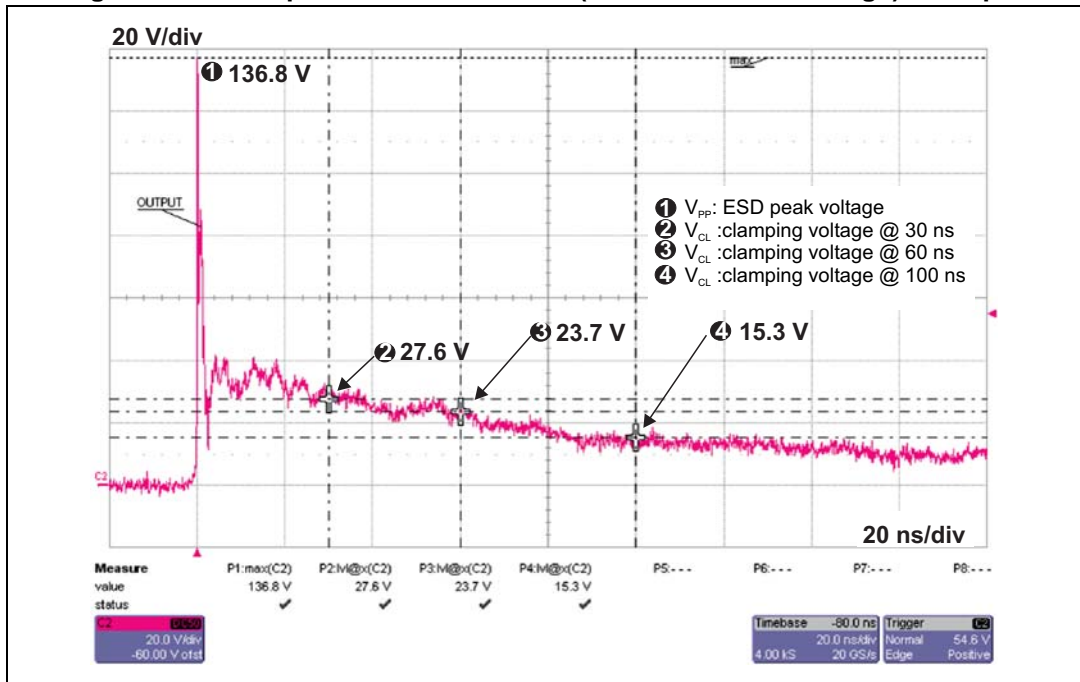

Figure 9. ESD response to IEC61000-4-2 (-8 kV contact discharge) on ID pin

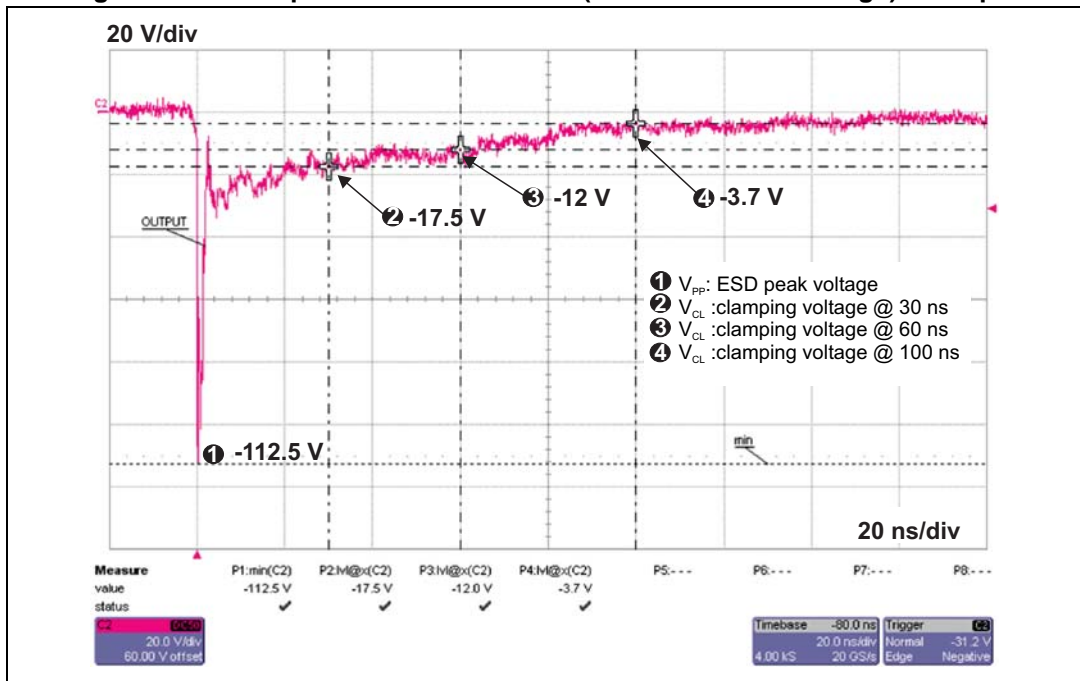

Figure 10. USB2.0 480 Mbps eye diagram without device

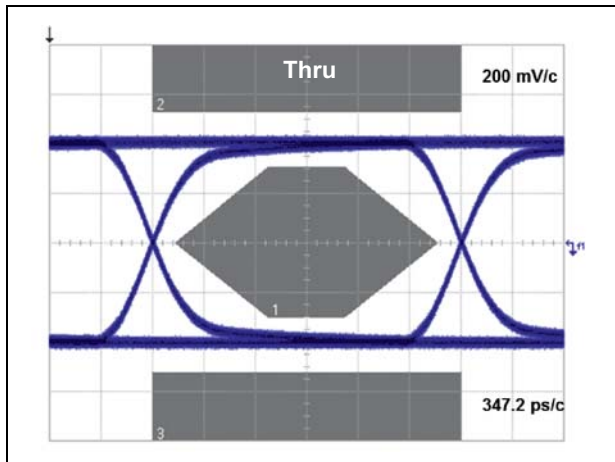

Figure 11. USB2.0 480 Mbps eye diagram with device

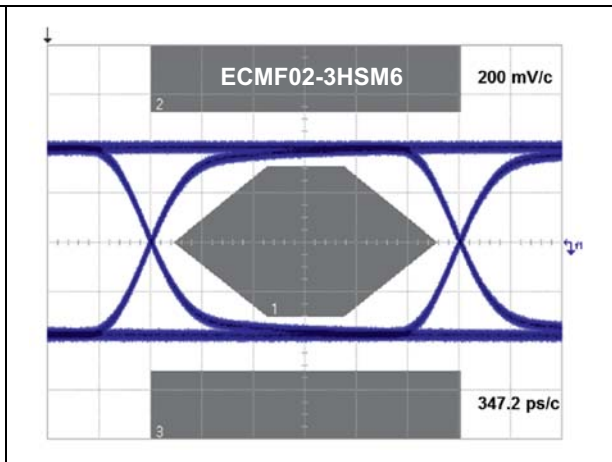

Figure 12. USB3.0 5 Gbps eye diagram without device

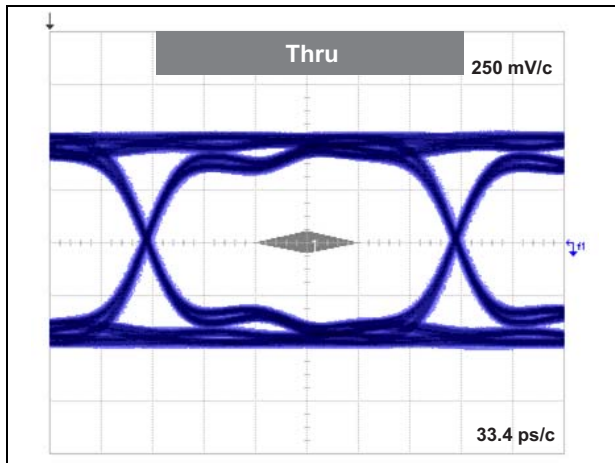

Figure 13. USB3.0 5 Gbps eye diagram with device

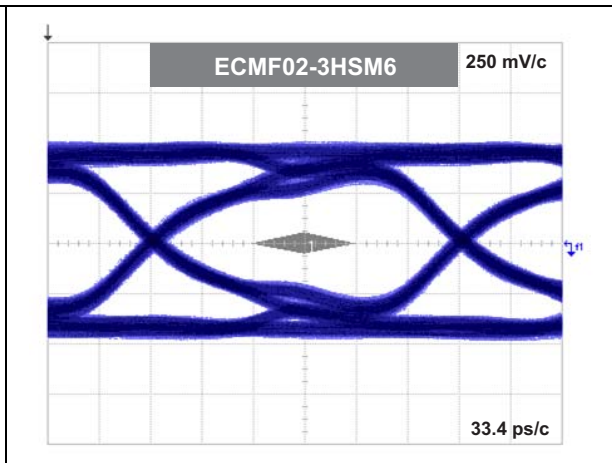

Figure 14. MHL 2.25 Mbps eye diagram without device

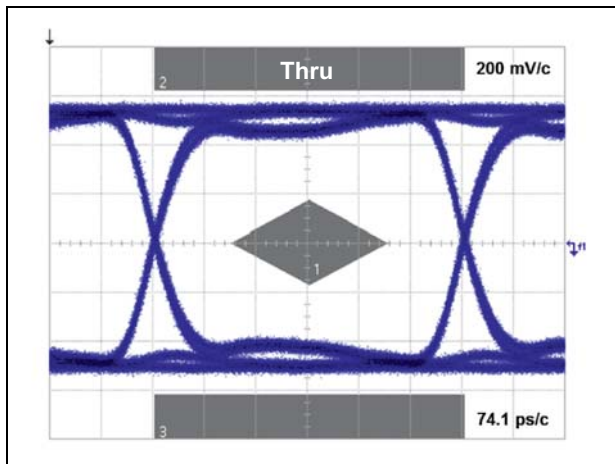

Figure 15. MHL 2.25 Mbps eye diagram with device

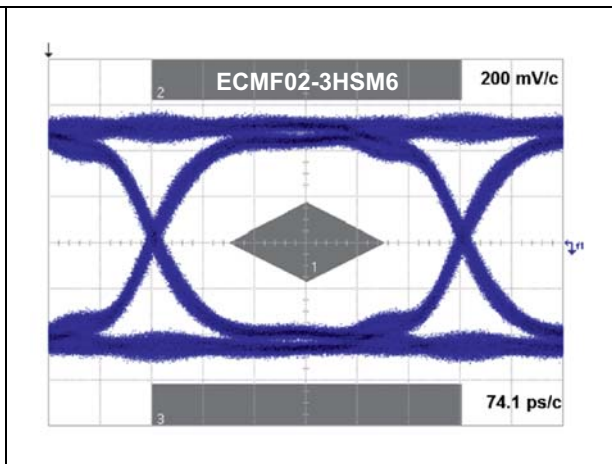
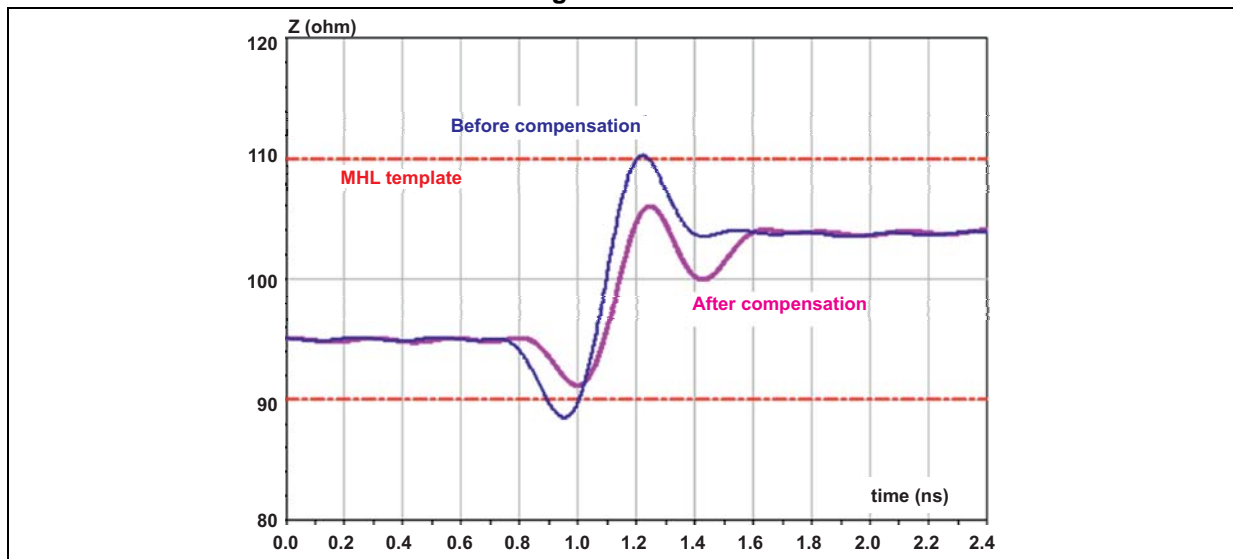
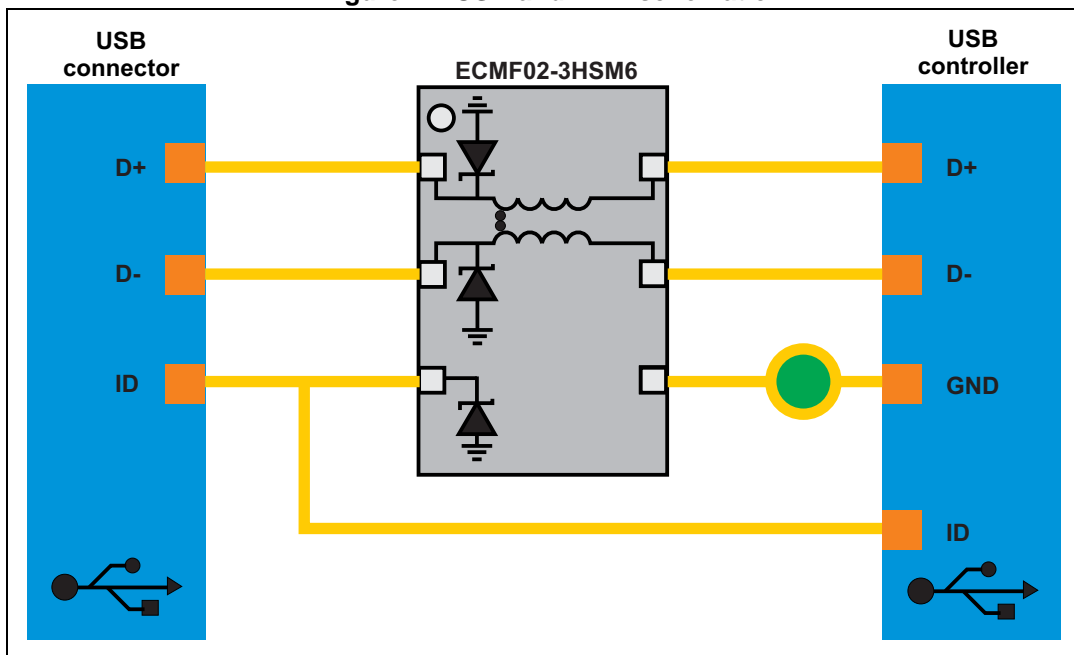

Figure 16. TDR



2 Application information

Figure 17. USB and MHL schematic



3 PCB layout recommendations

Figure 18. PCB layout recommendations

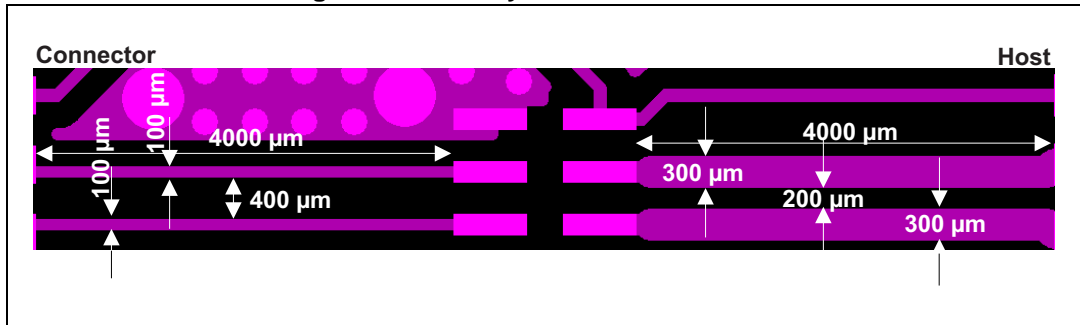
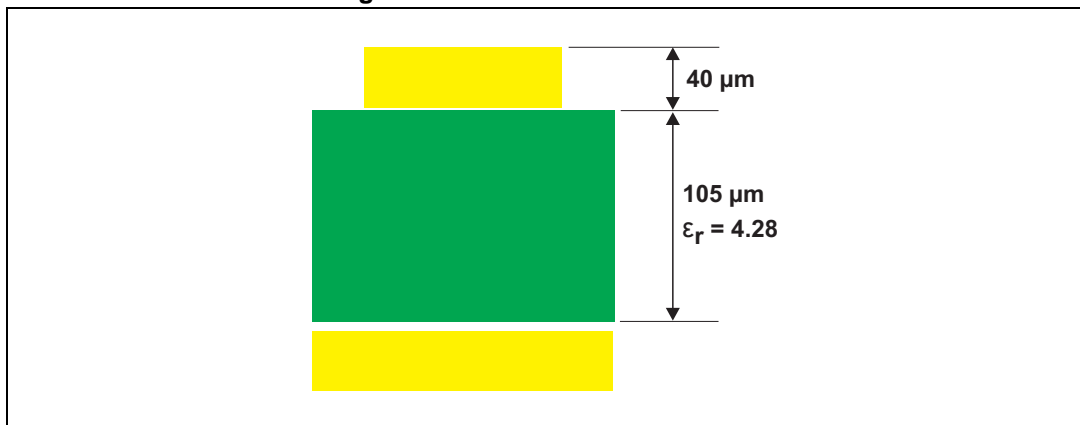

Figure 19. PCB stack dimensions



4 Package information

- Epoxy meets UL94, V0
- Lead-free package

In order to meet environmental requirements, ST offers these devices in different grades of ECOPACK® packages, depending on their level of environmental compliance. ECOPACK® specifications, grade definitions and product status are available at: www.st.com. ECOPACK® is an ST trademark.

Figure 20. μ QFN-6L dimension definitions

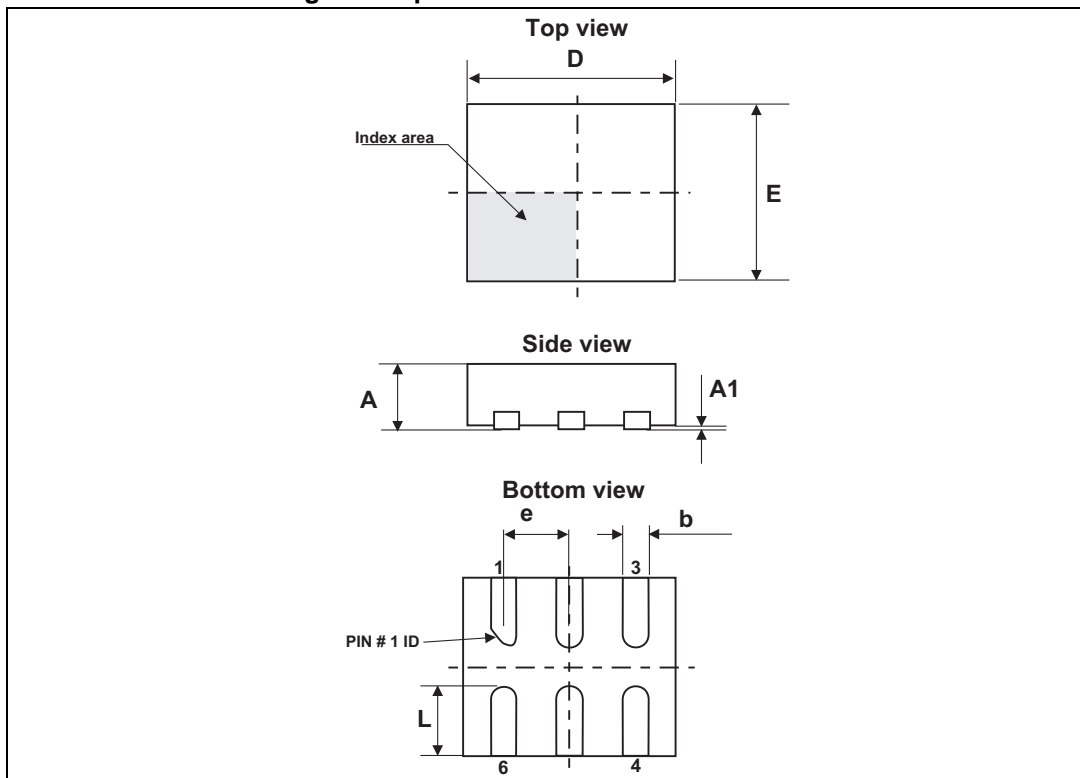

Table 3. μ QFN-6L dimension values

Ref.	Dimensions					
	Millimeters			Inches		
	Min.	Typ.	Max.	Min.	Typ.	Max.
A	0.45	0.50	0.55	0.018	0.020	0.022
A1	0.00	0.02	0.05	0.00	0.0008	0.002
b	0.15	0.20	0.25	0.006	0.008	0.010
D	1.55	1.60	1.65	0.061	0.063	0.065
E	1.30	1.35	1.40	0.051	0.053	0.055
e	0.45	0.50	0.55	0.018	0.020	0.022
L	0.40	0.50	0.60	0.016	0.020	0.024

Figure 21. Footprint

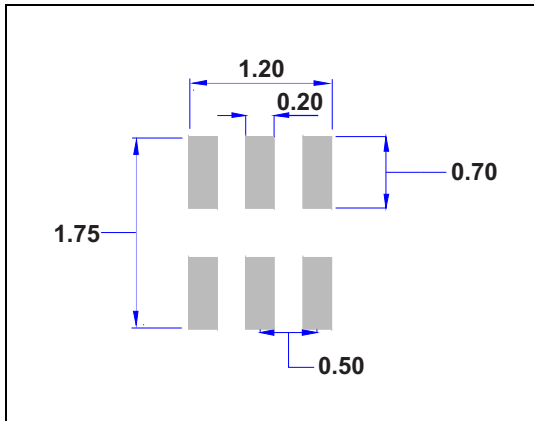
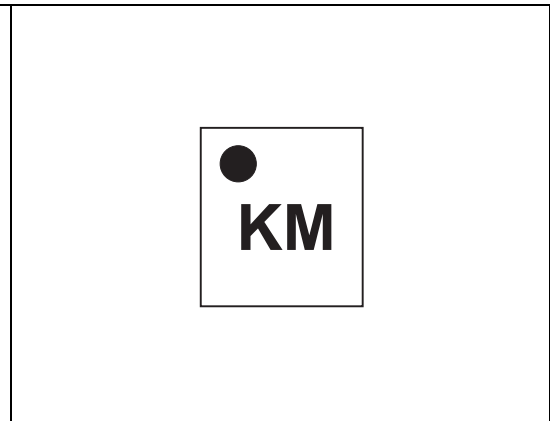
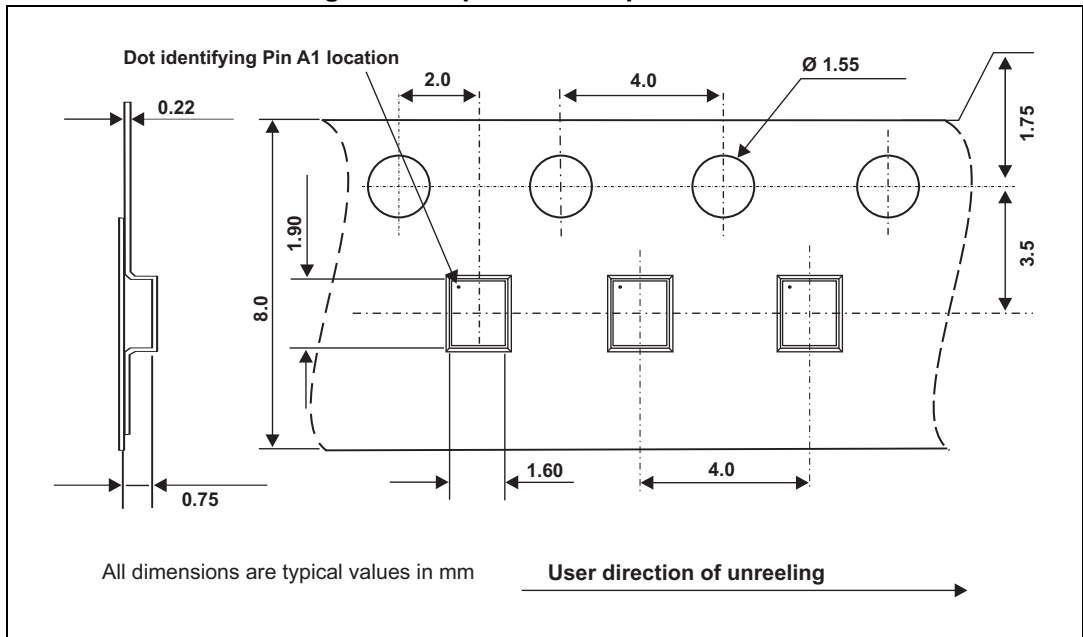

Figure 22. Marking



Note: Product marking may be rotated by multiples of 90° for assembly plant differentiation. In no case should this product marking be used to orient the component for its placement on a PCB. Only pin 1 mark is to be used for this purpose.

Figure 23. Tape and reel specifications



5 Ordering information

Figure 24. Ordering information scheme

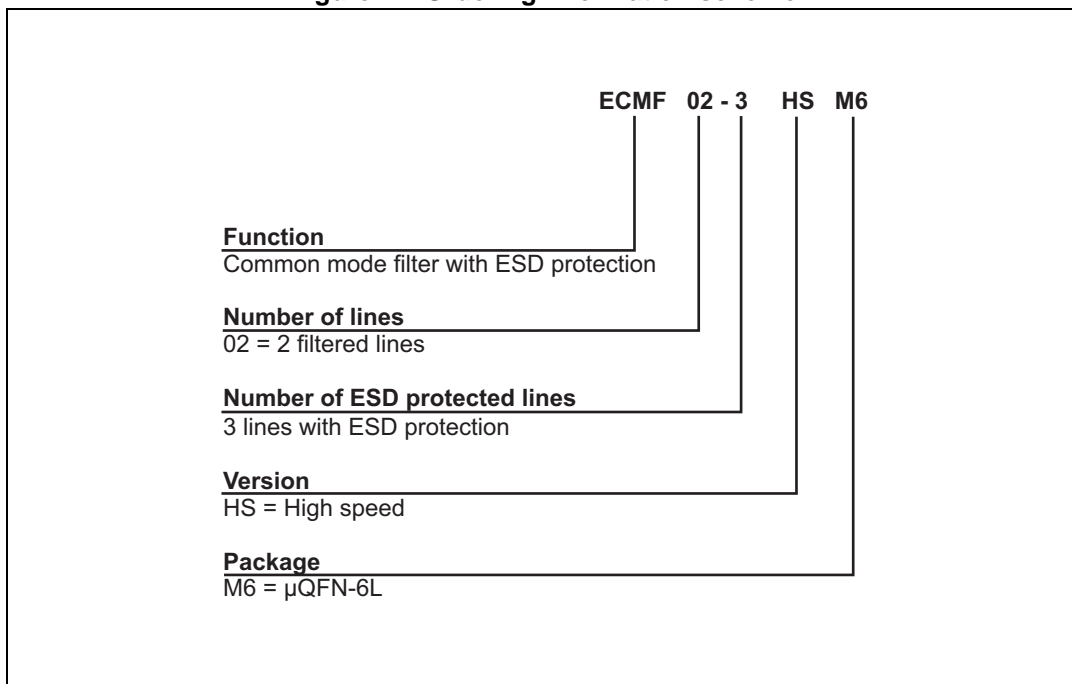

Table 4. Ordering information

Order code	Marking ⁽¹⁾	Package	Weight	Base qty	Delivery mode
ECMF02-3HSM6	KM	μ QFN-6L	3.03 mg	3000	Tape and reel

1. The marking can be rotated by multiples of 90° to differentiate assembly location

6 Revision history

Table 5. Document revision history

Date	Revision	Changes
02-Oct-2013	1	Initial release.

Please Read Carefully:

Information in this document is provided solely in connection with ST products. STMicroelectronics NV and its subsidiaries ("ST") reserve the right to make changes, corrections, modifications or improvements, to this document, and the products and services described herein at any time, without notice.

All ST products are sold pursuant to ST's terms and conditions of sale.

Purchasers are solely responsible for the choice, selection and use of the ST products and services described herein, and ST assumes no liability whatsoever relating to the choice, selection or use of the ST products and services described herein.

No license, express or implied, by estoppel or otherwise, to any intellectual property rights is granted under this document. If any part of this document refers to any third party products or services it shall not be deemed a license grant by ST for the use of such third party products or services, or any intellectual property contained therein or considered as a warranty covering the use in any manner whatsoever of such third party products or services or any intellectual property contained therein.

UNLESS OTHERWISE SET FORTH IN ST'S TERMS AND CONDITIONS OF SALE ST DISCLAIMS ANY EXPRESS OR IMPLIED WARRANTY WITH RESPECT TO THE USE AND/OR SALE OF ST PRODUCTS INCLUDING WITHOUT LIMITATION IMPLIED WARRANTIES OF MERCHANTABILITY, FITNESS FOR A PARTICULAR PURPOSE (AND THEIR EQUIVALENTS UNDER THE LAWS OF ANY JURISDICTION), OR INFRINGEMENT OF ANY PATENT, COPYRIGHT OR OTHER INTELLECTUAL PROPERTY RIGHT.

ST PRODUCTS ARE NOT DESIGNED OR AUTHORIZED FOR USE IN: (A) SAFETY CRITICAL APPLICATIONS SUCH AS LIFE SUPPORTING, ACTIVE IMPLANTED DEVICES OR SYSTEMS WITH PRODUCT FUNCTIONAL SAFETY REQUIREMENTS; (B) AERONAUTIC APPLICATIONS; (C) AUTOMOTIVE APPLICATIONS OR ENVIRONMENTS, AND/OR (D) AEROSPACE APPLICATIONS OR ENVIRONMENTS. WHERE ST PRODUCTS ARE NOT DESIGNED FOR SUCH USE, THE PURCHASER SHALL USE PRODUCTS AT PURCHASER'S SOLE RISK, EVEN IF ST HAS BEEN INFORMED IN WRITING OF SUCH USAGE, UNLESS A PRODUCT IS EXPRESSLY DESIGNATED BY ST AS BEING INTENDED FOR "AUTOMOTIVE, AUTOMOTIVE SAFETY OR MEDICAL" INDUSTRY DOMAINS ACCORDING TO ST PRODUCT DESIGN SPECIFICATIONS. PRODUCTS FORMALLY ESCC, QML OR JAN QUALIFIED ARE DEEMED SUITABLE FOR USE IN AEROSPACE BY THE CORRESPONDING GOVERNMENTAL AGENCY.

Resale of ST products with provisions different from the statements and/or technical features set forth in this document shall immediately void any warranty granted by ST for the ST product or service described herein and shall not create or extend in any manner whatsoever, any liability of ST.

ST and the ST logo are trademarks or registered trademarks of ST in various countries.

Information in this document supersedes and replaces all information previously supplied.

The ST logo is a registered trademark of STMicroelectronics. All other names are the property of their respective owners.

© 2013 STMicroelectronics - All rights reserved

STMicroelectronics group of companies

Australia - Belgium - Brazil - Canada - China - Czech Republic - Finland - France - Germany - Hong Kong - India - Israel - Italy - Japan - Malaysia - Malta - Morocco - Philippines - Singapore - Spain - Sweden - Switzerland - United Kingdom - United States of America

www.st.com