

CUSTOMER	SPC	FILE NO.	SPC19905
----------	-----	----------	----------

THIS DRAWING AND SPECIFICATIONS HEREIN ARE THE CONFIDENTIAL PROPERTY OF SAMAR AND SHALL NOT BE REPRODUCED OR COPIED OR DISCLOSED IN WHOLE OR IN PART WITHOUT WRITTEN PERMISSION.

REV.	DESCRIPTION	DRAWN / DATE	APPROVED / DATE
3	DEL PVC RING & REVISE UL No.	YANG 10/13/2010	LIN 10/13/2010
4	ADD DIM. & REVISED TOL.	YANG 02/10/2012	LIN 02/10/2012
5	ADD COLOR	FROS 10/17/2013	FROS 10/17/2013

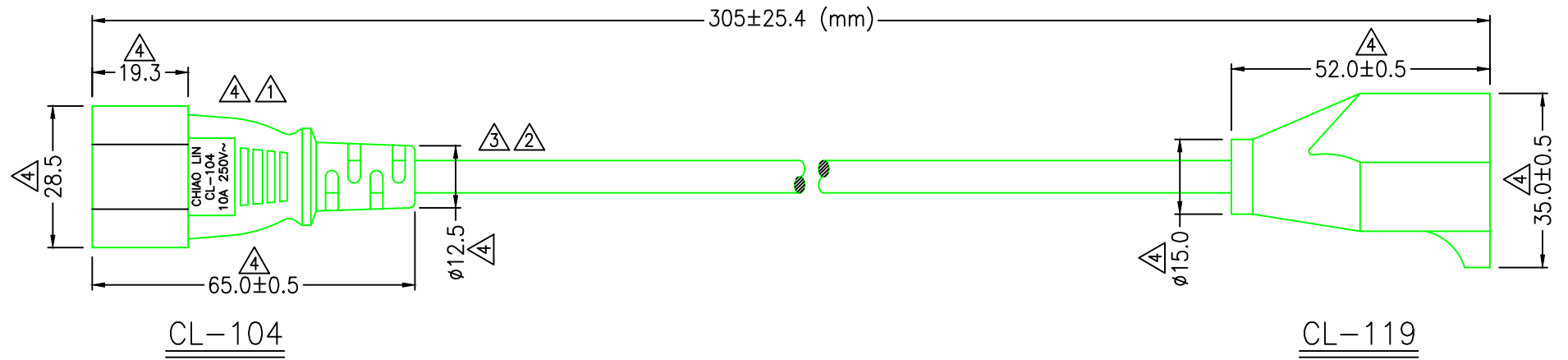
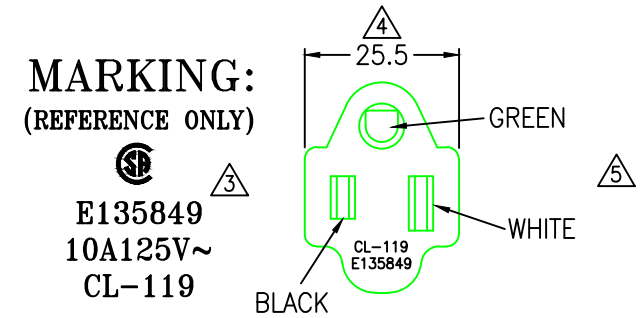
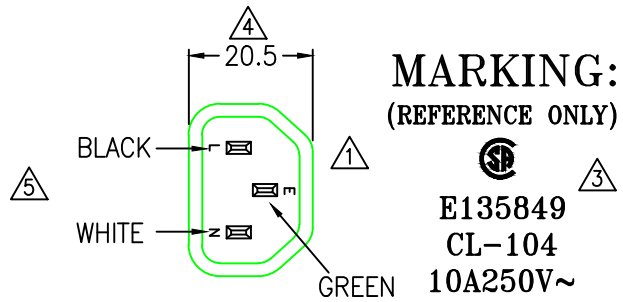

- NOTE:**
1. CABLE: SVT 18AWG*3C 60°C
 2. COLOR: BLACK
 3. CONNECTOR: CL-104/CL-119
 4. RATE: 10A 125V~
 5. SAFE: UL/CSA

RoHS

P/N	LENGTH (mm)	LENGTH (ft)
SPC19905	305±25.4	1
SPC19906	3658±50	12
SPC19907	1830±50	6

DIMENSIONS ARE IN mm [INCH]
MOLD NO.
SPC19905

TOLERANCES ARE FRACTIONS DECIMALS ANGLES
.X ± 0.20 [0.008]
.XX ± 0.12 [0.005]
ANGULAR ± 1°

MATERIAL
FINISH
COLOR



AC ADAPTOR CABLE,
L=1FT, RoHS

P/N	SPC19905
PROJECT NO.	
SCALE	N.T.S.
SIZE	A4
SHEET	1 OF 1

DRAWN	YANG	DATE	08/16/2006
			MC055