

# PRODUCT DATA SHEET

Part Number: 8UHR220

Type	Size	Rating	Description
Neon	T10	230VAC	T-3¼ Edison Screw Neon Lamp

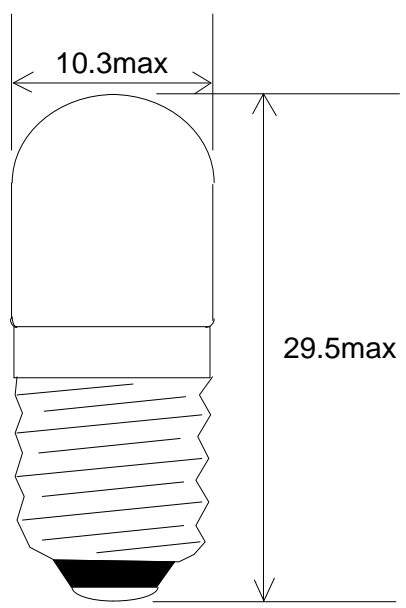

Dimensions in millimetres

Notes:

- 1 **Base Type** EX10/13 Edison screw Nickel plated brass
- 2 **Neon Type** 12.5/25UHB with 68KΩ ½W resistor
- 3 **Lamp Marking** **8UHR220 CML** indelibly marked on the base
- 4 **Environmental** RoHS & REACH SVHC compliant
- 5 **Packaging** Bags of 100