



Programming Cables

User's Guide

Features

- Support for all Lattice programmable products
 - 1.2 V to 3.3 V programming (HW-USBN-2B)
 - 1.2 V to 5 V programming (All other cables)
 - Ideal for design prototyping and debugging
- Connect to multiple PC interfaces
 - USB (v.1.0, v.2.0)
 - PC Parallel Port
- Easy-to-use programming connectors
 - Versatile flywire, 2 x 5 (.100") or 1 x 8 (.100") connectors
 - 6 feet (2 meters) or more of programming cable length (PC to DUT)
- Lead-free/RoHS compliant construction

Figure 1. USB Cable – HW-USBN-2B



Programming Cables

Lattice Programming Cable products are the hardware connection for in-system programming of all Lattice devices. After completion of the logic design and creation of a programming file with the Lattice Diamond®, ispLEVER® Classic or PAC-Designer® software, the Lattice Diamond Programmer, or Lattice's ispVM™ System software is used to control the programming of devices directly on the PC board. No additional components are required to program a device.

After you complete your logic design and create a programming file with the Lattice Diamond/ispLEVER Classic development tools, you can use Diamond Programmer or ispVM™ System software to program devices on your board. The ispVM System/Diamond Programmer software automatically generates the appropriate programming commands, programming addresses and programming data based on information stored in the programming file and parameters you set in Diamond Programmer/ispVM System. Programming signals are then generated from the USB or parallel port of a PC and directed through the Programming Cable to the device. No additional components are required for programming.

Diamond Programmer/ispVM System software is included with all Lattice design tool products and is available for download from the Lattice web site at www.latticesemi.com.

Programming Cable Pin Definitions

The functions provided by the Programming cables correspond with available functions on Lattice programmable devices. Since some devices contain different programming features, the specific functions provided by the Programming cable may depend on the selected target device. ispVM System/Diamond Programmer software will automatically generate the appropriate functions based on the selected device. See Table 1 for an overview of the Programming cable functions.

Table 1. Programming Cable Pin Definitions

Programming Cable Pin	Name	Programming Cable Pin Type	Description
VCC	Programming Voltage	Input	Connect to V _{CC} or V _{CCJ} plane of the target device. Typical I _{CC} = 10mA. Your board design supplies the power for V _{CC} . <i>Note: This may not be the same as a target device's V_{CC0} plane.</i>
SDO/TDO	Test Data Output	Input	Used to shift data out via the IEEE1149.1 (JTAG) programming standard.
SDI/TDI	Test Data Input	Output	Used to shift data in via the IEEE1149.1 programming standard.
ispEN/Enable/PROG/SN	Enable	Output	Enable device to be programmed. SN = SSPI Chip select for HW-USBN-2B
TRST	Test Reset	Output	Optional IEEE 1149.1 state machine reset.
DONE	DONE	Input	DONE indicates status of configuration
MODE/TMS	Test Mode Select Input	Output	Used to control the IEEE1149.1 state machine.
GND	Ground	Input	Connect to ground plane of the target device
SCLK/TCK	Test Clock Input	Output	Used to clock the IEEE1149.1 state machine
INIT	Initialize	Input	Indicates that ORCA [®] device is ready for configuration.
I2C: SCL ¹	I2C SCL	Output	Provides the I2C signal SCL
I2C: SDA ¹	I2C SDA	Output	Provides the I2C signal SDA.
5V Out ¹	5V Out	Output	Provides a 5V signal for the iCEprog M1050 Programmer.

1. Only found on the HW-USBN-2B cable.

Figure 2. Programming Cable In-System Programming Interface for the PC (HW-USBN-2B)¹

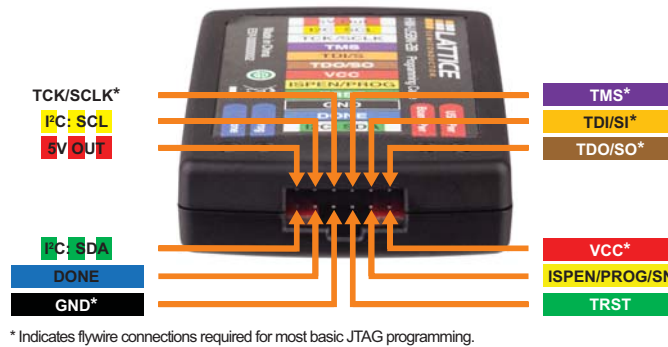

1. Requires Diamond Programmer 3.1 or later

Figure 3. Programming Cable In-System Programming Interface for the PC (HW-USB-1A or HW-USB-2A)¹

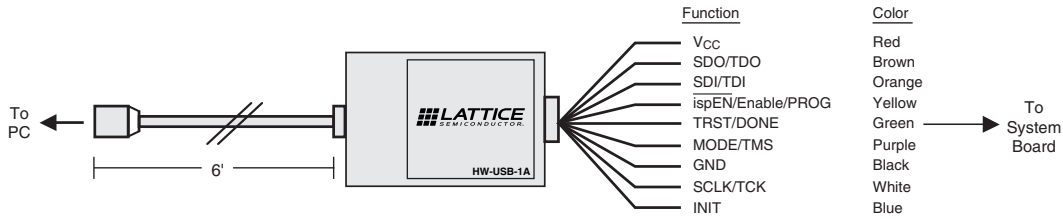

1. Lattice PAC-Designer[®] software does not support programming with USB cables. To program ispPAC devices with these cables, use the Diamond Programmer/ispVM System software.

Figure 4. Programming Cable In-System Programming Interface for the PC (HW-DLN-3C and Equivalents)¹

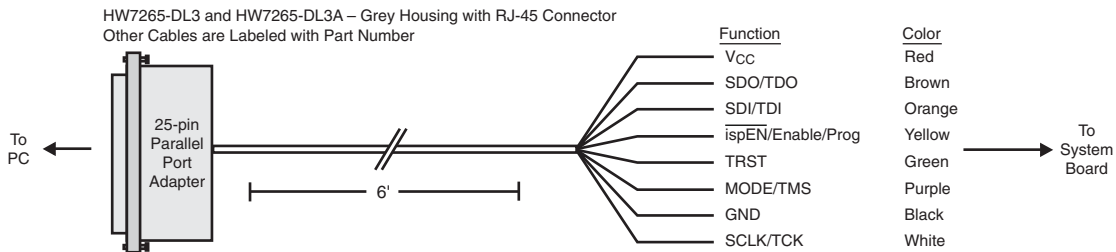

1. HW7265-DL3, HW7265-DL3A, HW-DL-3B, HW-DL-3C and HW-DLN-3C are functionally equivalent products.

Figure 5. Programming Cable In-System Programming Interface for the PC (pDS4102-DL2 or pDS4102-DL2A)

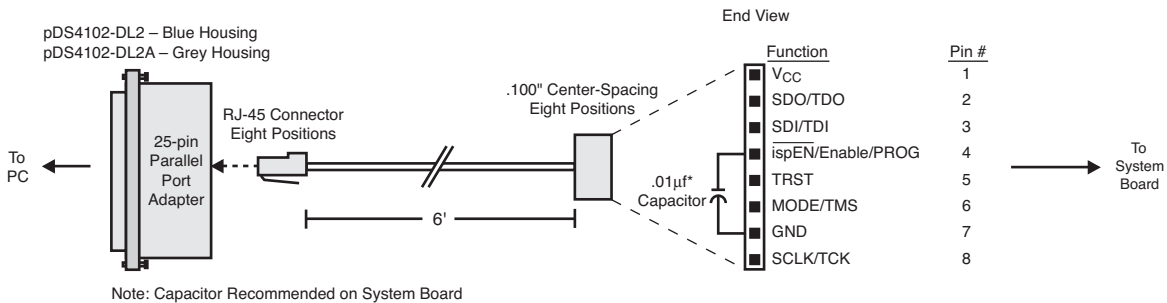
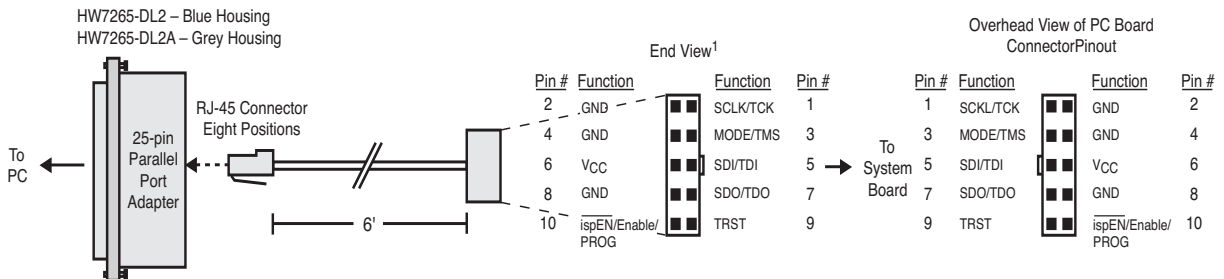

Figure 6. Programming Cable In-System Programming Interface for the PC (HW7265-DL2 or HW7265-DL2A)



1. For reference purposes, the 2x10 connector on the HW7265-DL2 or HW7265-DL2A is equivalent to Tyco 102387-1. This will interface to standard 100-mil spacing 2x5 headers, or a 2x5 keyed, recessed male connector such as the 3M N2510-5002RB.

Programming Software

Diamond Programmer and ispVM System for Classic devices is the preferred programming management software tool for all Lattice devices and download cables. The latest version of Lattice Diamond Programmer or ispVM System software is available for download from the Lattice web site at www.latticesemi.com/software.

Target Board Design Considerations

A 4.7K pull-down resistor is recommended on the TCK connection of the target board. This pull-down is recommended to avoid inadvertent clocking of the TAP controller induced by fast clock edges or as V_{CC} ramps up. This pull-down is recommended for all Lattice programmable families.

The I²C signals SCL and SDA are open drain. A 2.2K pull-up resistor to VCC is required on the target board.

For Lattice device families that feature low power, it is recommended to add a 500 ohm resistor between V_{CCJ} and GND during the programming interval when a USB Programming cable is connected to a very low power board design. A FAQ is available that discusses this in more depth at:

<http://www.latticesemi.com/en/Support/AnswerDatabase/2/2/0/2205>

The JTAG programming port speed may need to be governed when using the Programming cables connected to customer PCBs. This is especially important when there is long PCB routing or with many daisy-chained devices. The Lattice programming software can adjust the timing of TCK applied to the JTAG programming port from the cable. This low-precision port setting of TCK depends on many factors, including the PC speed and the type of cable used (parallel port, USB or USB2). This software feature provides an option to slow the TCK for debug or noisy environments. A FAQ is available that discusses this in more depth at:

<http://www.latticesemi.com/en/Support/AnswerDatabase/9/7/974.aspx>

The USB Download Cable can be used to program Power Manager or ispClock products with Lattice programming software. When using the USB cable with the Power Manager I devices, (POWR604, POWR1208, POWR1208P1), you must slow do TCK by a factor of 2. A FAQ is available that discusses this in more depth at:

<http://www.latticesemi.com/en/Support/AnswerDatabase/3/0/306.aspx>

Programming Flywire and Connection Reference

Refer to Table 2 when connecting a flywire download cable to systems that use the 1x8-position or 2x5-position connectors. For newer Lattice FPGA families, a 1x10 connector used in conjunction with the Programming USB cable adds support for the DONE and INITN signals. Both of these signals are inputs to the cable, and can be used to help verify device configuration.

Table 2. Flywire Conversion Reference

Function	Flywire Cable	Wire Label	1x10 Connector	1x8 Connector	2x5 Connector
V_{CC}^1	Red	VCC	1	1	6
TDO/SO/SPI_SO	Brown	TDO	2	2	7
TDI/SI/SPI_SI	Orange	TDI	3	3	5
ispEN ² /Enable/PROGRAMN/SN/SPI_SS_B	Yellow	ispEN/PROG	4	4	10
TRST ³ /CRESET_B	Green	TRST/DONE	5	5	9
TMS/MODE	Purple	TMS	6	6	3
GND	Black	GND	7	7	4 (2 and 8)
TCK ⁴ /SCLK/CCLK/SPI_SCK	White	TCK	8	8	1
DONE ³	Green	TRST/DONE	9		
INITN/CDONE	Blue	INITN	10		
I2C SCL ^{5,6}	Yellow/White	I2C: SCL			
I2C SDA ^{5,6}	Green/White	I2C: SDA			

Table 2. Flywire Conversion Reference (Continued)

Function	Flywire Cable	Wire Label	1x10 Connector	1x8 Connector	2x5 Connector
5V Output ⁵	Red/White	5V Out			

- For devices that have a V_{CCJ} pin, the V_{CCJ} must be connected to the cable's V_{CC} , and a 0.1 μ F decoupling capacitor is required on V_{CCJ} close to the device. Please refer to the device data sheet to determine if the device has a V_{CCJ} pin.
- For older Lattice ISP devices, a 0.01 μ F decoupling capacitor is required on $\overline{\text{ispEN}}/\text{ENABLE}$ of the target board.
- The TRST and DONE pin is multiplexed on the Programming USB cable. If the device TRST signal is available on the board, connect the USB flywire TRST/DONE wire to TRST. If the device DONE signal is available on the board (or if both TRST and DONE are available), connect the USB flywire TRST/DONE wire to DONE. Please make sure the correct setting is selected in ispVM/Diamond Programmer (Options, Cable and I/O Port Setup). This will tell ispVM/Diamond Programmer whether the TRST/DONE cable is used as a TRST or a DONE signal.
- A 4.7K pull-down resistor is recommended on TCK of the target board.
- Only on the HW-USB2N-2B cable
- Open drain signals. External pull-up ~2.2KOhm resistor to VCC is required.

Table 3 lists the recommend pin connections. Please contact Lattice technical support for information on unlisted device families. (e-mail: techsupport@latticesemi.com).

Table 3. Recommended Pin Connections

Device Family	TDI	TDO	TMS	TCK	ispEN/P ROG ^{1,6}	TRST ² /D ONE ^{3,6}	INITN ^{3,6}	VCC	GND	SCL	SDA
ECP5 TM	Mandatory	Mandatory	Mandatory	Mandatory	Optional	Optional	Optional	Mandatory	Mandatory	N/A	N/A
LatticeECP3 TM	Mandatory	Mandatory	Mandatory	Mandatory	Optional	Optional	Optional	Mandatory	Mandatory	N/A	N/A
LatticeECP2M TM /LatticeECP2 TM	Mandatory	Mandatory	Mandatory	Mandatory	Optional	Optional	Optional	Mandatory	Mandatory	N/A	N/A
LatticeECP TM /LatticeEC TM	Mandatory	Mandatory	Mandatory	Mandatory	Optional	Optional	Optional	Mandatory	Mandatory	N/A	N/A
LatticeXP2 TM	Mandatory	Mandatory	Mandatory	Mandatory	Optional	Optional	Optional	Mandatory	Mandatory	N/A	N/A
LatticeXP TM	Mandatory	Mandatory	Mandatory	Mandatory	Optional	Optional	Optional	Mandatory	Mandatory	N/A	N/A
LatticeSC TM /LatticeSCM TM	Mandatory	Mandatory	Mandatory	Mandatory	Optional	Optional	Optional	Mandatory	Mandatory	N/A	N/A
iCE40 TM /iCE40LM/iCE40 Ultra TM	Mandatory	Mandatory	N/A	Mandatory	Mandatory	Recom- mended	Recom- mended	Mandatory	Mandatory	N/A	N/A
MachXO2 TM /MachXO3 TM	Mandatory	Mandatory	Mandatory	Mandatory	N/A	N/A	N/A	Mandatory	Mandatory	Optional	Optional
MachXO TM	Mandatory	Mandatory	Mandatory	Mandatory	N/A	N/A	N/A	Mandatory	Mandatory	N/A	N/A
ORCA [®] /FPSC	Mandatory	Mandatory	Mandatory	Mandatory	Optional	Optional	Optional	Mandatory	Mandatory	N/A	N/A
ispXPGA [®]	Mandatory	Mandatory	Mandatory	Mandatory	N/A	N/A	N/A	Mandatory	Mandatory	N/A	N/A
ispXPLD TM	Mandatory	Mandatory	Mandatory	Mandatory	N/A	N/A	N/A	Mandatory	Mandatory	N/A	N/A
ispMACH [®] 4000	Mandatory	Mandatory	Mandatory	Mandatory	N/A	N/A	N/A	Mandatory	Mandatory	N/A	N/A
ispMACH/ispLSI [®] 5000	Mandatory	Mandatory	Mandatory	Mandatory	N/A	N/A	N/A	Mandatory	Mandatory	N/A	N/A
MACH [®] 4A ⁴	Mandatory	Mandatory	Mandatory	Mandatory	N/A	N/A	N/A	Mandatory	Mandatory	N/A	N/A
ispGDX2 TM	Mandatory	Mandatory	Mandatory	Mandatory	N/A	N/A	N/A	Mandatory	Mandatory	N/A	N/A
ispClock TM	Mandatory	Mandatory	Mandatory	Mandatory	N/A	N/A5	N/A	Mandatory	Mandatory	N/A	N/A
Platform Manager TM	Mandatory	Mandatory	Mandatory	Mandatory	N/A	Optional ⁵	N/A	Mandatory	Mandatory	N/A	N/A
Power Manager/Power Manager II	Mandatory	Mandatory	Mandatory	Mandatory	N/A	Optional ⁵	N/A	Mandatory	Mandatory	N/A	N/A
ispPAC [®]	Mandatory	Mandatory	Mandatory	Mandatory	N/A	N/A	N/A	Mandatory	Mandatory	N/A	N/A

- Refer to the Programming Cable $\overline{\text{ispEN}}$ Pin section below for detailed information on connecting the $\overline{\text{ispEN}}/\text{ENABLE}$ pin.
- Refer to the Programming Cable TRST Pin section below for detailed information on connecting the TRST pin.
- The DONE and INITN signals are only available on the Programming USB cable. These signals are inputs to the cable and can be used to help verify device configuration.
- Please refer to the device data sheet. Not all packages have the ENABLE or TRST pin.
- When using PAC-Designer[®] software to program ispPAC devices, do not connect this pin.
- When using these connections, be sure to select the correct settings in the Cable and I/O Port Setup dialog in the ispVM System/Diamond Programmer software.

Connecting the Programming Cable

The target board must be un-powered when connecting, disconnecting, or reconnecting the Programming Cable. Always connect the Programming Cable's GND pin (black wire), before connecting any other JTAG pins. Failure to follow these procedures can result in damage to the target programmable device.

Programming Cable TRST Pin

Connecting the board TRST pin to the cable TRST pin is not recommended. Instead, connect the board TRST pin to Vcc. If the board TRST pin is connected to the cable TRST pin, instruct ispVM/Diamond Programmer to drive the TRST pin high as follows:

1. Select the **Options** menu item.
2. Select **Cable and I/O Port Setup**.
3. Check the **TRST/Reset Pin Connected** checkbox.
4. Select the **Set High** radio button.

If the proper option is not selected, the TRST pin will be driven low by ispVM/Diamond Programmer. Consequently, the BSCAN chain will not work because the chain will be locked into RESET state.

Programming Cable $\overline{\text{ispEN}}$ Pin

The following pins should be grounded:

- BSCAN pin of the 2000VE devices
- ENABLE pin of MACH4A3/5-128/64, MACH4A3/5-64/64 and MACH4A3/5-256/128 devices.

However, the user has the option of having the BSCAN and ENABLE pins driven by the $\overline{\text{ispEN}}$ pin from the cable. In this case, ispVM/Diamond Programmer must be configured to drive the $\overline{\text{ispEN}}$ pin low as follows:

1. Select the **Options** menu item.
2. Select **Cable and I/O Port Setup**.
3. Check the **$\overline{\text{ispEN}}$ /BSCAN Pin Connected** checkbox.
4. Select the **Set Low** radio button.

Table 4. Programming Cable Feature Summary

Feature	HW-USBN-2B	HW-USBN-2A	HW-USB-2A	HW-USB-1A	HW-DLN-3C	HW7265-DL3, HW7265-DL3A, HW-DL-3B, HW-DL-3C	HW7265-DL2	HW7265-DL2A	PDS4102-DL2	PDS4102-DL2A
USB	X	X	X	X						
PC-Parallel					X	X	X	X	X	X
1.2 V Support	X	X	X							
1.8 V Support	X	X	X	X	X	X		X		X
2.5-3.3 V Support	X	X	X	X	X	X	X	X	X	X
5.0 V Support		X	X	X	X	X	X	X	X	X
2x5 Connector		X	X	X	X	X	X	X		
1x8 Connector		X	X	X	X	X			X	X
Flywire	X	X	X	X	X	X				
Lead-free Construction	X	X			X					
Available for order	X				X					

Each Programming Cable ships with two small connectors that help you keep the flywires organized. The following manufacturer and part number is one possible source for equivalent connectors:

- 1x8 Connector (e.g. Samtec SSQ-108-02-T-S)
- 2x5 Connector (e.g. Samtec SSQ-105-02-T-D)

The Programming Cable flywire or headers are intended to connect to standard 100-mil spacing headers (pins spaced 0.100 inch apart). Lattice recommends a header with length of 0.243 inches or 6.17 mm. Though, headers of other lengths may work equally well.

Ordering Information

Description	Ordering Part Number	China RoHS Environment-Friendly Use Period (EFUP)
Programming cable (USB). Contains 6' USB cable, flywire connectors, 8-position (1x8) adapter and 10-position (2x5) adapter, lead-free, RoHS compliant construction.	HW-USBN-2B	
Programming cable (PC only). Contains parallel port adapter, 6' cable, flywire connectors, 8-position (1x8) adapter and 10-position (2x5) adapter, lead-free, RoHS compliant construction.	HW-DLN-3C	

Note: Additional cables are described in this document for legacy purposes only, these cables are no longer produced. The cables currently available for order are fully equivalent replacement items.

Technical Support Assistance

e-mail: techsupport@latticesemi.com

Internet: www.latticesemi.com

Revision History

Date	Version	Change Summary
January 2015	24.7	Updated Programming Cable Pin Definitions section. — In Table 1, Programming Cable Pin Definitions, ispEN/Enable/PROG changed to ispEN/Enable/PROG/SN and its description revised. — Updated Figure 2, Programming Cable In-System Programming Interface for the PC (HW-USBN-2B).
		Updated Programming Cable ispEN Pin section. In Table 4, Programming Cable Feature Summary, HW-USBN-2B marked as available for order.
		Updated Ordering Information section. HW-USBN-2A changed to HW-USBN-2B
July 2014	24.6	Changed document title to Programming Cables User's Guide
		Changed ispDOWNLOAD Cables to Programming Cables.
		Updated Target Board Design Considerations section. Updated FAQ link on ispVM tool control of TCK duty cycle and/or frequency.
		Updated Table 3, Recommended Pin Connections. Added ECP5, iCE40LM, iCE40 Ultra, and MachXO3 device families.
October 2012	24.5	Added iCE40 configuration port pin names to the Flywire Conversion Reference table.
		Added iCE40 information to Recommended Cable Connections table.
February 2012	24.4	Updated document with new corporate logo.
November 2011	24.3	Document transferred to user's guide format.
		Added Figure USB Cable – HW-USBN-2A.
		Updated Recommend Cable Connections table for MachXO2 devices.
		Updated Target Board Design Considerations section.
October 2009	24.2	Added information related to the physical specifications of the flywire connectors.
		Added Target Board Design Considerations text section. Added Programming Flywire and Connection Reference section heading.
—	—	Previous Lattice releases.

Appendix A. Troubleshooting the USB Driver Installation

It is essential that you install the drivers before connecting your PC to the USB cable. If the cable is connected before installing the drivers, Windows will try to install its own drivers that may not work.

If you have attempted to connect the PC to the USB cable without first installing the appropriate drivers, or have trouble communicating with the Lattice USB cable after installing the drivers, following the steps below:

1. Plug in the Lattice USB cable. Choose **Start > Settings > Control Panel > System**. In the System Properties dialog box, click the **Hardware** tab and **Device Manager** button. Under Universal Serial Bus controllers, you should see Lattice USB ISP Programmer. If you do not see this, look for the Unknown Device with the yellow flag.

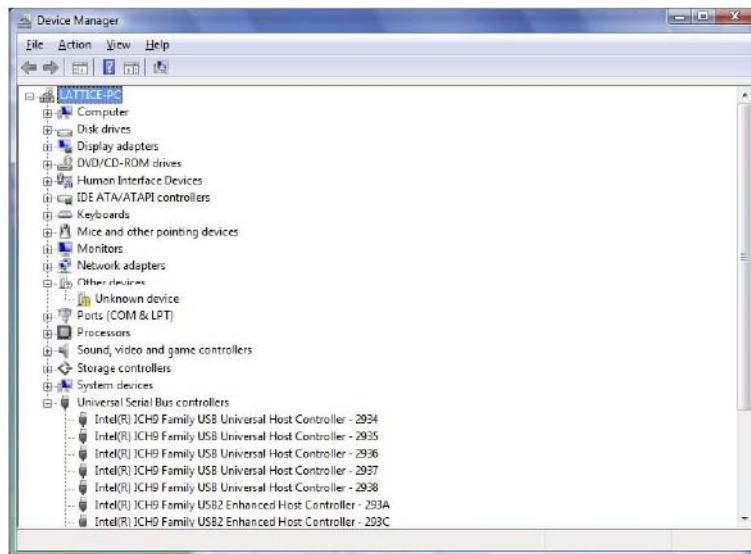

2. Double click on the **Unknown Device** icon.

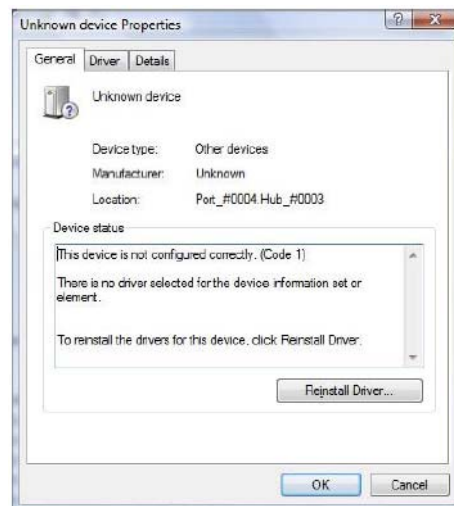

3. Click **Reinstall Driver**.

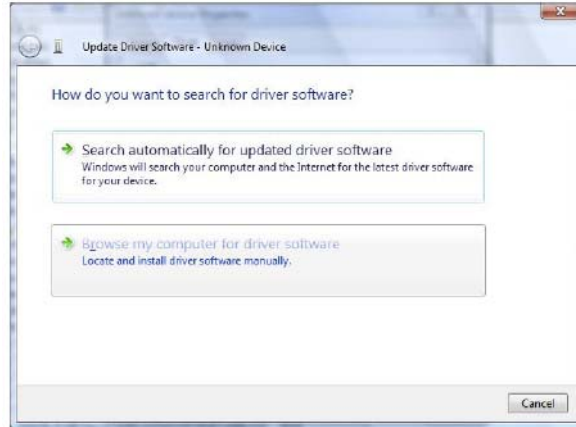

4. Select **Browse for driver software on your computer**.

For Lattice EzUSB Driver

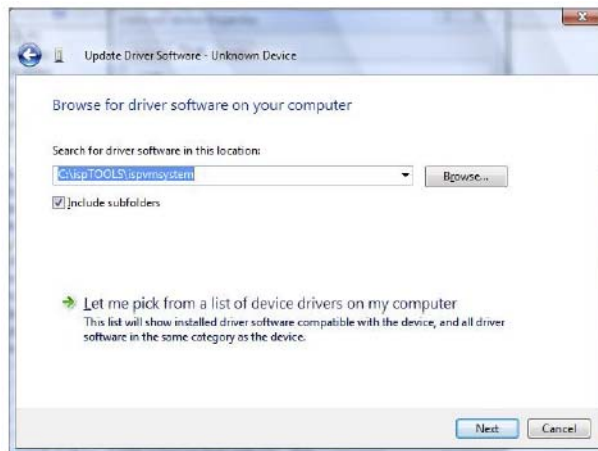

For FTDI FTUSB Driver

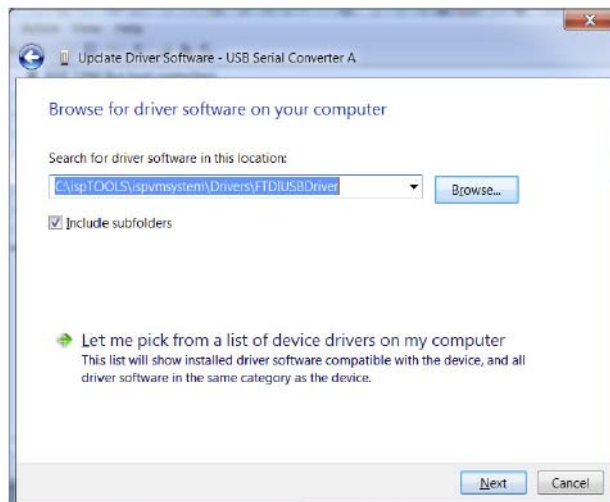

5. Browse to the **isptools\ispvmsystem** directory for the Lattice EzUSB driver or the **isptools\ispvmsystem\Drivers\FTDIUSBDriver** directory for the FTDI FTUSB driver. For Diamond installations, browse to **Iscc/diamond/data/vmdata/drivers**. Click **Next**.



6. Select **Install this Driver software anyway**. The system will update the driver.

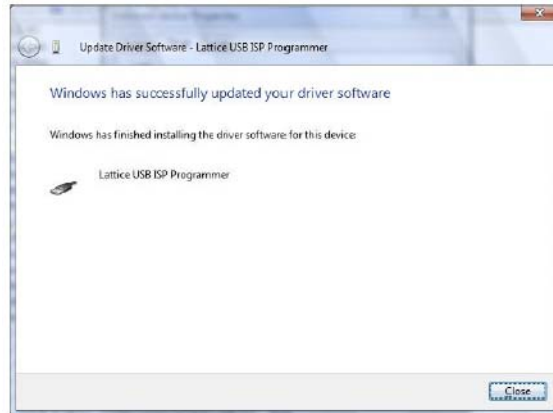

7. Click **Close** and finish installing the USB driver. Under **Control Panel >System >Device Manager > Universal Serial Bus Controllers** should include the following:

For the Lattice EzUSB Driver: Lattice USB ISP Programmer device installed.

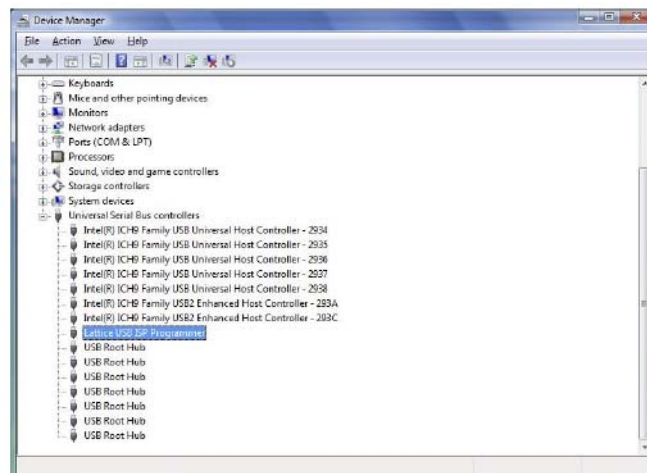

For the FTDI FTUSB Driver: USB Serial Converter A and Converter B devices installed.

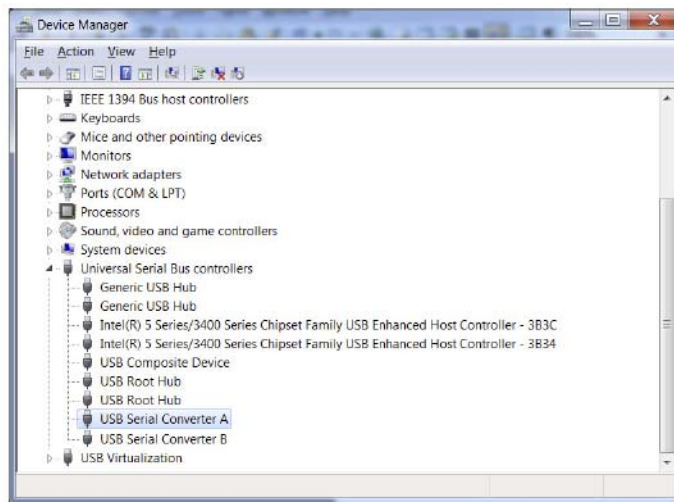

If you are experiencing problems or need additional information, contact Lattice Technical Support.