

RES60F20

Rev. 0

CHARACTERISTICS:

Rated Voltage:	250VAC max
Rated Current at Ambient:	20A @ 40°C
Operating Frequency:	DC-400HZ
Climatic Class (IEC60068-1):	25/100/21
Temperature Range:	-25°C to +100°C
Over load Current:	1.5 x Rated Ct. for 1 Min
Operational Leakage current : (at 230VAC/50Hz and Total C +/-20%)	0.73 mA max
Worst case Leakage current : (N interrupted and Total C +/-20%)	<1.301 mA max
DCR @ 25°C (+/-25%) :	100 mΩ
Test Voltage (100%) for 2 sec:-	L-N: 1100VDC L-GND: 3000VDC
Ingress Protection:	IP 20
Weight (Approximate):	460 gr

FILTER PARAMETERS:

Total Inductance (L-L'+N-N') @10KHz:	1.2mH +50%,-30%
Total Capacitance (L-L/L-N) @1KHz:	2.0μF +/- 20%
Total Capacitance (L/N-GND) @1KHz:	9.4nF +/- 20%
Total Resistance (L-L/L-N):	0.22MΩ +/- 10%
Total Resistance (L/N-GND):	

APPROVALS:

REACH
RoHS
UL



APPROVED
BY
AJAY

Date:25-01-2014

CIRCUIT DIAGRAM:

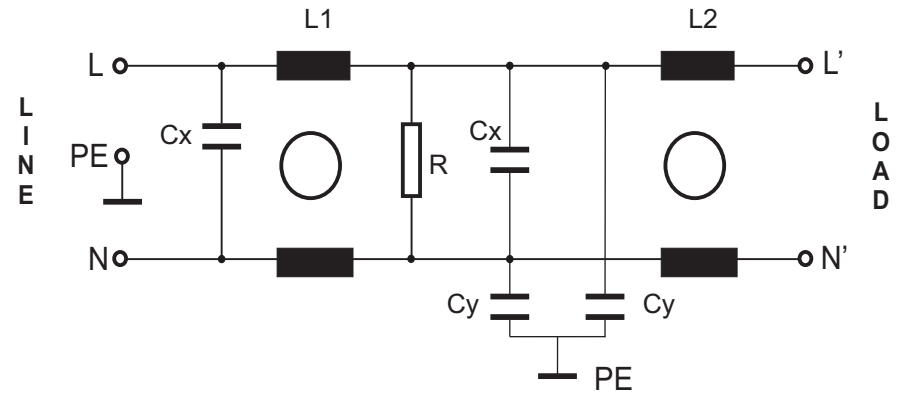

MECHANICAL DIMENSION (mm):

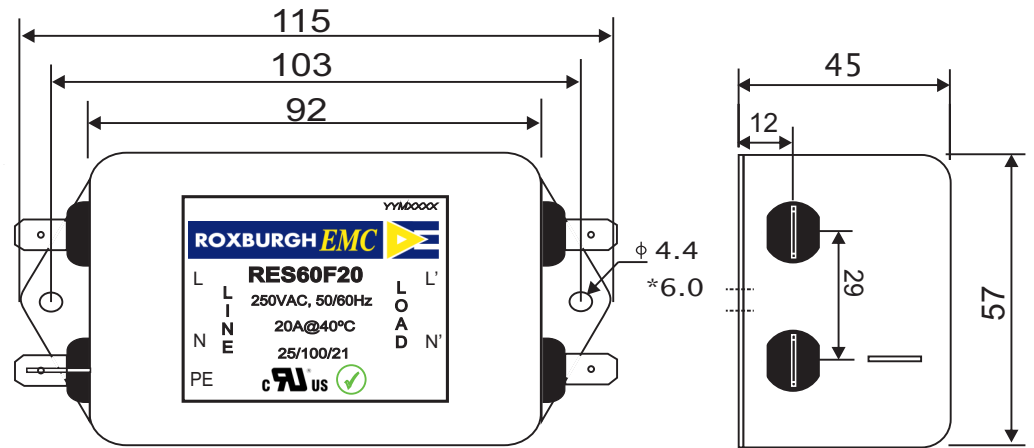

Note:

Housing matl. Fe with Ni Plated
Fast-On Terminal (6.38 x 0.8mm) or
Screw 8-32,1.5" Connections

TOLERANCE: +/-1.0 mm



Tel:- +44(0) 1724 273200
email:- sales@dem-uk.com
web :- www.dem-uk.com/roxburgh

ROXBURGH EMC

FILTER INSERTION LOSS CHARACTERISTICS CISPR 17 - 50 OHM METHOD

RES60F20

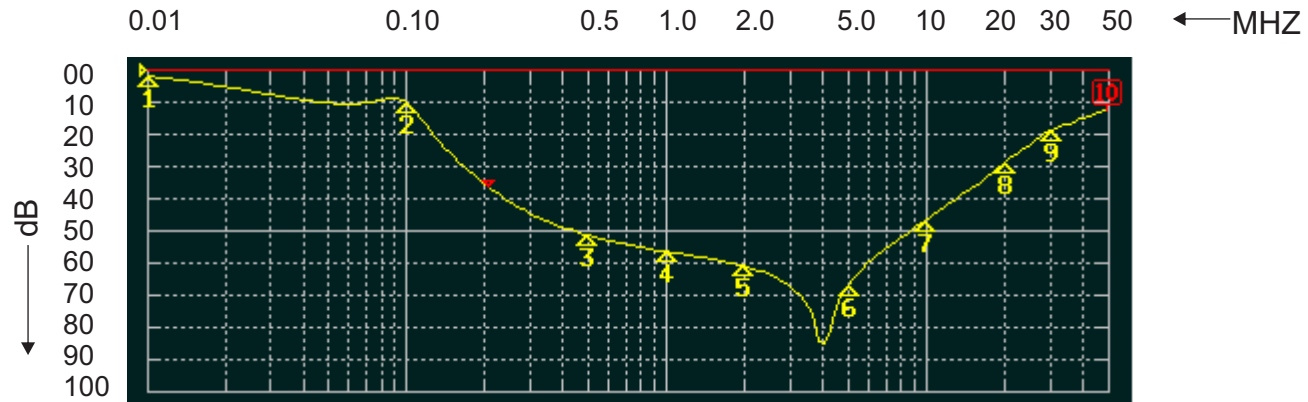

COMMON MODE

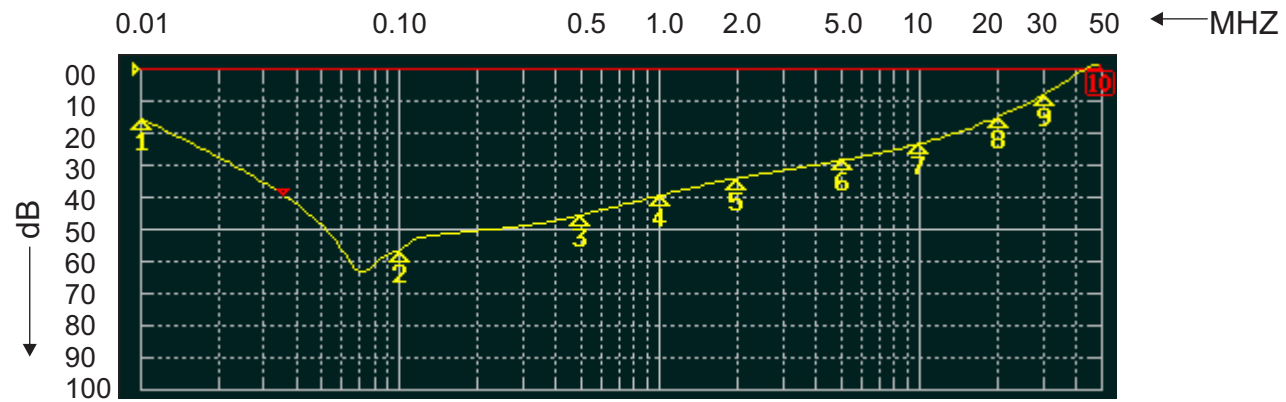

DIFFERENTIAL MODE

