

LQH3NPN470MM0#

" # " indicates a package specification code.

Available **General** **85** **Wound (Shield)** **Thickness 1.5mm max.** **Reflow OK** **RoHS**

< List of part numbers with package codes >
LQH3NPN470MM0L , LQH3NPN470MM0K

Shape

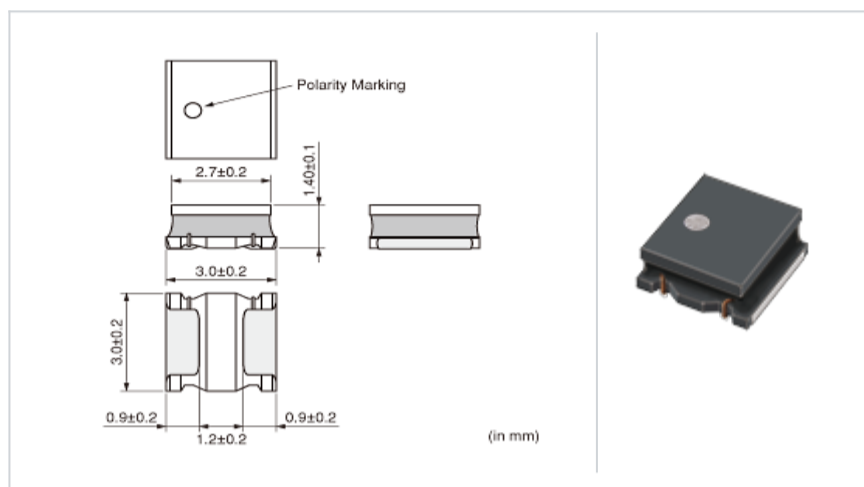

L size	3.0 ± 0.2mm
W size	3.0 ± 0.2mm
T size	1.4 ± 0.1mm
Size code in inch (mm)	1212 (3030)

Notes

When applied Rated current to the Products, Inductance will be within ± 30% of nominal Inductance value.
When applied Rated current to the Products, temperature rise caused by self-generated heat shall be limited to 40 °C max.
Keep the temperature (ambient temperature plus self-generation of heat) under 125 °C.

References

Packaging code	Specifications	Minimum quantity
L	180mm Embossed taping	1000
K	330mm Embossed taping	4000

Mass (Typ.)	
1 piece	0.051g

Specifications

Inductance	47µH ± 20%
Inductance test frequency	1MHz
Rated current (Isat) (Based on Inductance change)	310mA
Rated current (Itemp) (Based on Temperature rise)	410mA
Max. of DC resistance	1.50
Avg. of DC resistance	1.25 ± 20%
Self resonance frequency (min.)	18MHz
Operating temperature range (Self-temperature rise is included)	-40 ~ 125
Operating temperature range (Self-temperature rise is not included)	-40 ~ 85
Class of magnetic shield	Magnetic shield of magnetic powder in resin

Attention

- This datasheet is downloaded from the website of Murata Manufacturing Co., Ltd. Therefore, it ' s specifications are subject to change or our products in it may be discontinued without advance notice. Please check with our sales representatives or product engineers before ordering.
- This datasheet has only typical specifications because there is no space for detailed specifications. Therefore, please review our product specifications or consult the approval sheet for product specifications before ordering.

Inductance-Frequency characteristics (Typ.)

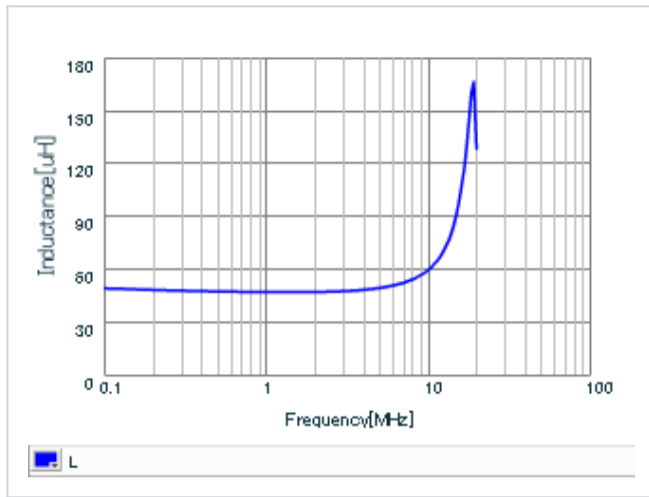

Inductance-Current characteristics (Typ.)

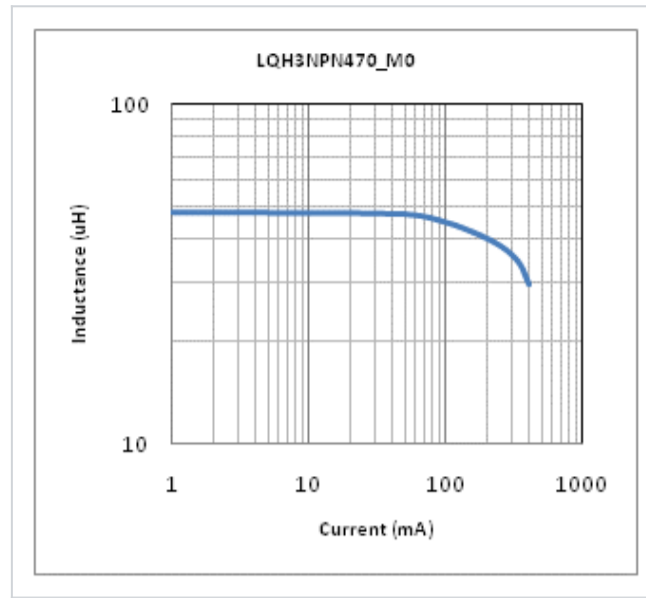

Temperature rise characteristics (Typ.)

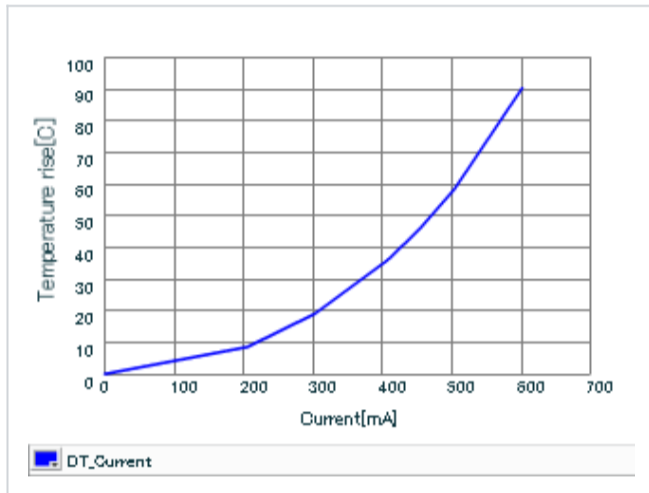

This PDF data has only typical specifications because there is no space for detailed specifications. Therefore, please review our product specifications or consult the approval sheet for product specifications before ordering.