

LTC4120EUD Wireless Power Receiver and 400mA Buck Battery Charger

DESCRIPTION

Demonstration circuit 2181 is an [LTC®4120EUD](#) demonstration board. The DC2181 is used with the DC1968A wireless power transmitter or the PowerByProxi ProxiPoint transmitter (both available separately). Either can deliver 2W to the DC2181, with up to 10mm spacing between the transmitter and the receive coil. The basic transmitter doesn't support foreign metal object detection. Transmitters available separately. See last page for details.

FEATURED PART

DC2181A-A	LTC4120EUD-4.2 (Fixed Output)
DC2181A-B	LTC4120EUD (Adjustable Output)

Design files for this circuit board are available at <http://www.linear.com/demo/DC2181A>

LT, LT, LTC, LTM, Linear Technology and the Linear logo are registered trademarks of Linear Technology Corporation. All other trademarks are the property of their respective owners.

PERFORMANCE SUMMARY

Specifications are at $T_A = 25^\circ\text{C}$

SYMBOL	PARAMETER	CONDITIONS	MIN	TYP	MAX	UNITS
HVIN	DC1968A High Voltage Input Voltage Range	$I_{HVIN} \leq 500\text{mA}$ at $HVIN = 8\text{V}$	8		38	V
V_{CC}	DC1968A V_{CC} Input Range	$I_{V_{CC}} = 0 \sim 700\text{mA}$	4.75		5.25	V
V(BAT)	DC2181A BAT Pin Voltage	$R9 = 1.40\text{M}\Omega$, $R10 = 1.05\text{M}\Omega$	2.5		4.25	V
I(BAT)	DC2181A BAT Pin Current	$V(\text{BAT}) = 3.7\text{V}$, DC1967A(R5) = $3.01\text{k}\Omega$, All Bar Graph LEDs on.	370	380	390	mA

BOARD PHOTO

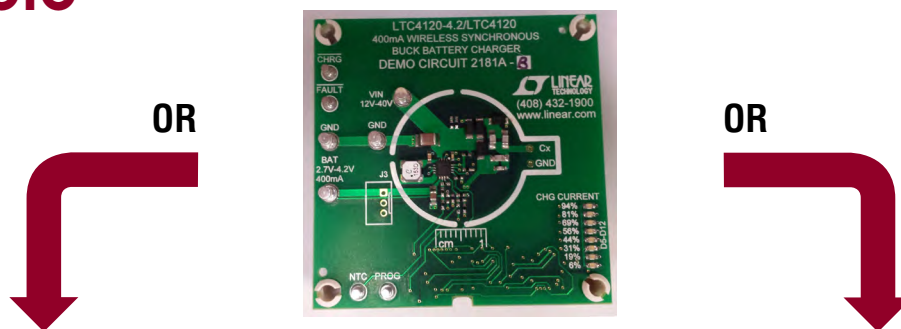

Figure 1. DC2181 Wireless Power Receiver Demo Board

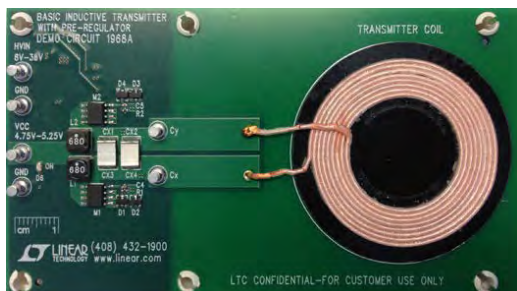

Figure 2. DC1968A Wireless Power Basic Transmitter Demo Board

← NOTE: These boards are not included with DC2181 and must be ordered separately. See last page for details. →



Figure 3. PowerByProxi ProxiPoint Transmitter

ASSEMBLY TEST PROCEDURE

For the proper measurement equipment setup and jumper settings refer to Figure 6a, if you are using the DC1968A wireless power basic transmitter, or Figure 5a, if you are using the PowerByProxi ProxiPoint transmitter. Please follow the checkout procedure, below, to familiarize yourself with the DC2181 demo board.

NOTE: When measuring the input or output voltage ripple, care must be taken to avoid a long ground lead on the oscilloscope probe. Measure the input or output voltage ripple by touching the probe tip directly across the V_{CC} or V_{IN} and GND terminals. See Figure 4 for proper scope probe technique.

1. Connect power to the transmitter. For the DC1968A basic transmitter set PS1 to 5V, and turn on. For the PowerByProxi ProxiPoint transmitter, plug in the power supply that came with the transmitter.
2. Set PS2 to 3.6V, and turn the supply on. PS2 is the battery emulator *battery* voltage. The purpose of the 3.6Ω is to make PS2 into a bipolar supply. Most power supplies can only source current not sink current, bipolar supplies can do both. A bipolar supply is necessary for a battery emulator, as it must absorb the current coming from the charger. By placing a 3.6Ω resistor in parallel with a normal supply, the supply can absorb up to 1A, at 3.6V.
3. Place the DC2181A receive board on the transmitter as shown in Figure 5c, if you are using the PowerByProxi ProxiPoint transmitter. Or as shown in Figure 6c, if using the DC1968A. Note: for the ProxiPoint transmitter, the LED the ProxiPoint transmitter should change from green to solid red. If the LED turns blinking red, please remove the DC2181A board, wait until the LED turns green, and once again place the DC2181 on the transmitter. If the ProxiPoint transmitter LED does not change to solid red on the second try, please contact your FAE.
4. The green bar graph LEDs on the DC2181 demo board should light. Observe AM1, there is an additional 10mA flowing from the BAT into the bar graph LEDs. Please ensure that VM1 measures less than 4V. If not lower PS2 until it does.

The bar graph LEDs indicate the percent of programmed charge current flowing into the battery. They do so by monitoring the PROG voltage. PROG will be 1V, at full programmed charge current.

If you lower the battery emulator voltage, by lowering PS2, until VM1 reads approximately 2.9V, you will see the bar graph drop to 10%. This is the trickle current, which is set to 10% of the programmed charge current.

5. Test is complete.

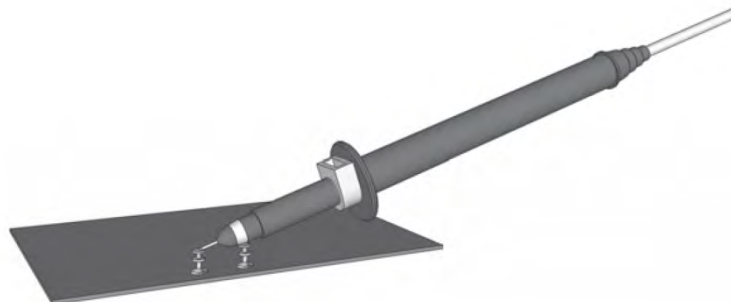

Figure 4. Proper Measurement Technique for Measuring Ripple

ASSEMBLY TEST PROCEDURE

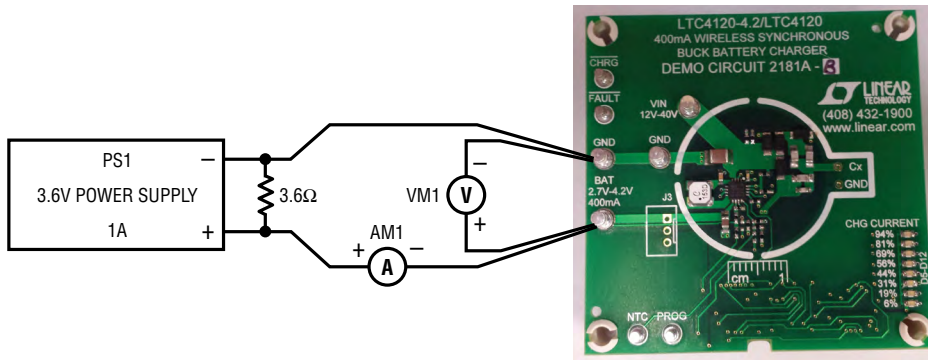

Figure 5a. DC2181A-A/B Wireless Power Demo Board Connection



Figure 5b. PowerByProxi's ProxiPoint Transmitter

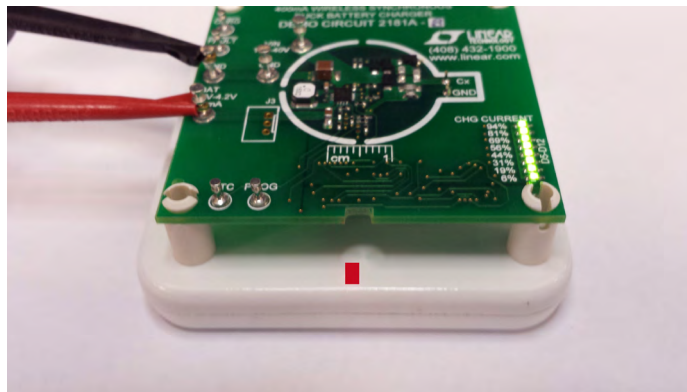

Figure 5c. DC2181A-A/B Wireless Power Demo Board Mounted on PowerByProxi's ProxiPoint Transmitter

Note: All connections from equipment should be Kelvin connected directly to the board pins which they are connected on this diagram and any input or output leads should be twisted pair.

ASSEMBLY TEST PROCEDURE

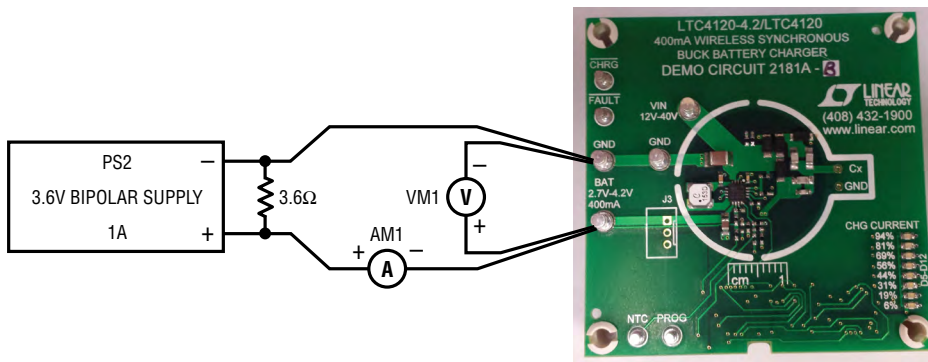

Figure 6a. DC2181A-A/B Wireless Power Demo Board Connection

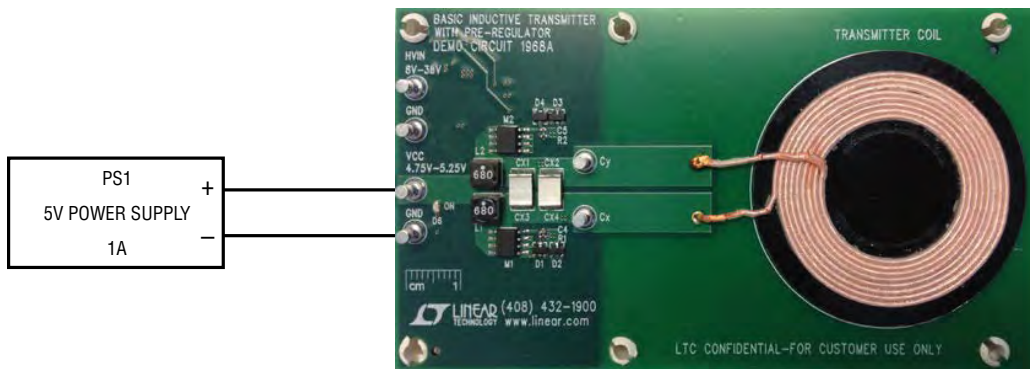

Figure 6b. DC1968A Wireless Power Basic Transmitter Connection

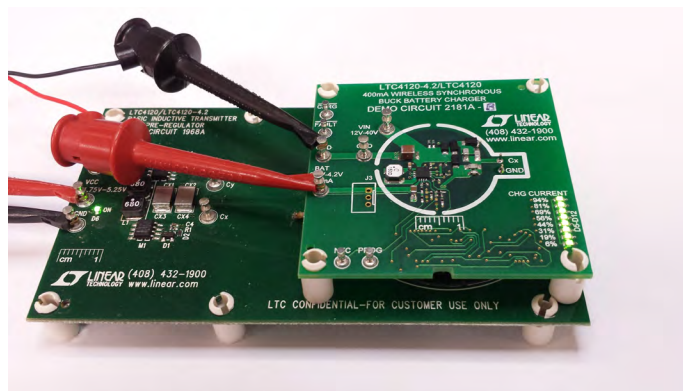

Figure 6c. DC2181A-A/B Wireless Power Demo Board Mounted on DC1968A Wireless Power Basic Transmitter

Note: All connections from equipment should be Kelvin connected directly to the board pins which they are connected on this diagram and any input or output leads should be twisted pair.

THEORY OF OPERATION

The DC2181A demo board demonstrates operation of a double tuned magnetically coupled resonant power transfer circuit. The DC2181A demo Board must be used in conjunction with either the DC1968A wireless power basic transmitter or the PowerByProxi ProxiPoint transmitter.

For theory of operation of the PowerByProxi ProxiPoint transmitter, please refer to the ProxiPoint documentation.

DC1968A – Basic Transmitter

The DC1968A basic transmitter is used to transmit wireless power and is used in conjunction with the DC2181A wireless power receiver board featuring the LTC4120.

The DC1968A is configured as a current fed astable multi-vibrator, with oscillation frequency set by a resonant tank. The DC1968A basic transmitter is set to 130kHz operation and the DC1967A LTC4120 demonstration board resonant frequency is 127kHz with DHC enabled and 140kHz with DHC disabled. For the DC1968A basic transmitter the resonant components are the 2X 0.15 μ F PPE film capacitors (Cx1 and Cx2) and the 5.0 μ H (Lx) transmit coil (see Schematic: Basic Inductive Transmitter with Pre-Regulator). This gives a resonant frequency of 129.95kHz. The tolerance on the transmit coil and resonant capacitors is $\pm 2\%$, or 2.6kHz. Inductors L1 and L2 are used to make the resonant structure current fed.

The current fed topology makes the peak-to-peak voltage on the resonant tank equal to $2\pi V_{CC}$. V_{CC} is 5V, so the peak-to-peak tank voltage is 31.5V, see Figure 7.

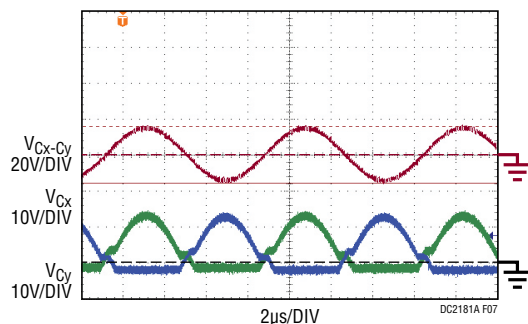

Figure 7. DC1968A Basic Transmitter

The blue and green traces are the drains of the transmitter MOSFETs M1 and M2 (see Schematic: Basic Inductive Transmitter with Pre-Regulator), respectively. The red trace is the difference ($V_{Cx} - V_{Cy}$) of those two nodes, and shows that the resonant tank is producing a sine wave. The peak-to-peak voltage of $2\pi V_{CC} = 31.5V$, results from the current fed topology. This in turn determines the breakdown of the MOSFETs and diodes D2 and D3. To increase transmit power by raising V_{CC} , you must also change M1, M2, D2 and D3, to reflect the higher voltages on the C_X and C_Y nodes.

The magnitude of the magnetic field is directly proportional to the current in the transmit coil. For a resonant system this current is Q times the input current. So the higher the Q the larger the magnetic field. Therefore the transmit coil is constructed with Litz wire, and the resonant capacitors are very low dissipation PPS film capacitors. This leads to a Q of approximately 10 at 130kHz, and a circulating current of approximately 6A_{P-P}, at full load.

DC2181 – Wireless Power Receiver Board Featuring the LTC4120

The DC2181 LTC4120 wireless power receiver IC implements dynamic harmonization control (DHC), which tunes or detunes the receive circuit to receive more or less power as needed. The primary receive tank is composed of AE1, and C2S, although it must be noted that C2S is AC grounded through C5, the LTC4120 decoupling capacitor, to be in parallel with AE1. C2S also serves to tap power off the resonant circuit and send it to the LTC4120, (see Schematic: 400mA Wireless Synchronous Buck Battery Charger).

THEORY OF OPERATION

The waveforms in Figure 8 were captured at a transmit-to-receive gap of 8mm. The blue trace is the waveform at the C_X pin of the receiver board (see Schematic: 400mA Wireless Synchronous Buck Battery Charger), and the red trace is the charge current into the battery. Although the transmit waveform is a sine wave, the series-parallel connection of the secondary resonant circuit does not yield a sine wave, and this waveform is correct. The charge current into the battery has an average of $\approx 400\text{mA}$, for a delivered power of 1.5W ($V_{\text{BAT}} = 3.7\text{V}$). However, 10mA has been diverted to the charge LEDs, for a net battery charge current of 390mA . The ripple on the charge current is synchronous to the transmit waveform.

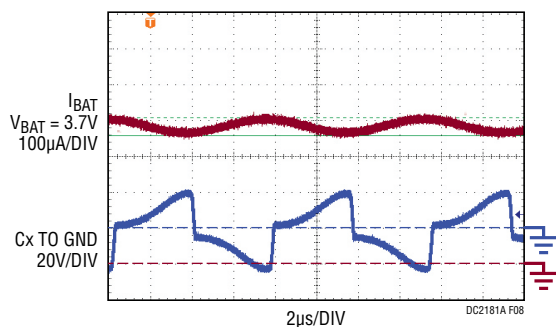

Figure 8. DC2181A Receiver Board

DHC

When V_{IN} is above 14V , the DHC pin is open and $C2P$ doesn't enhance the energy transfer; this is the detuned state, and the resonant frequency of the receive tank is 142kHz . When V_{IN} falls below 14V , the DHC pin is grounded putting $C2P$ in parallel with both $C2S$ and $AE1$ thus changing the resonant frequency to 127.4kHz . When the receiver is tuned at 127.4kHz and drawing significant power, the transmit frequency is pulled down to 127kHz . So, at full power the system is now a double-tuned resonant circuit. Figure 10 shows approximate power transfer vs distance between transmitter and receiver. Note the minimum clearance. The minimum is needed to avoid exceeding the maximum input voltage.

Summary

The LTC4120 wireless power receiver IC adjusts the receiver resonant frequency to keep the system from transferring too much power when the coupling is high between transmit and receive coils. The LTC4120 wireless power receiver IC increases power transfer when power transfer is insufficient. This is accomplished by switching capacitors into the resonant circuit using the DHC pin. This gives a much wider operating transmit distance.

Figure 9 shows V_{IN} to the LTC4120 and the battery charge current. The blue trace is the charge current into the battery, and the red trace is the voltage at V_{IN} on the receiver board. V_{IN} is about 25V , while the LTC4120 delivers 1.5W at a distance of 8mm , to the battery. There is negligible transmit frequency ripple on V_{IN} , and the voltage is well above the 14V DHC voltage. This indicates that the input rectifiers are operating in peak detect mode, and that DHC is inactive.

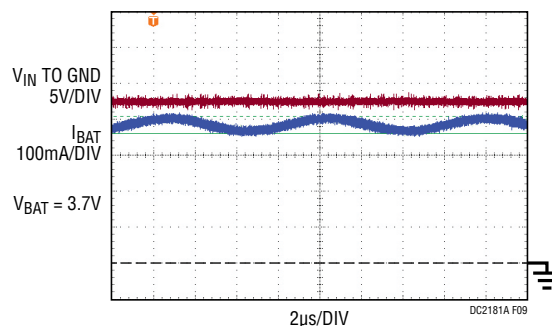

Figure 9. DC2181A Receiver

THEORY OF OPERATION

AE1, the Receive Antenna

One of the main differences between the DC1967A and the DC2181 demo boards, is that the wireless power receive antenna is separate for the DC2181 demo board.

Several antennas were tested, with the criteria of passing 2.5W at 8mm spacing. The following table lists the antennas that passed successfully:

MANUFACTURER	CONSTRUCTION	MFG PART NUMBER
TDK	Ferrite on PCB	B67410-A0223-X195
Inter-Technical	Ferrite on PCB	L41200R01
Inter-Technical	Ferrite on PCB	L41200R02*
Inter-Technical	Litz on Ferrite	L41200R03
Inter-Technical	Litz on Ferrite	L41200R04
Inter-Technical	Ferrite on PCB	L41200R05
TDK	Wire on Ferrite	WR282830-37M8-LR4
Würth	Wire on Ferrite	760308101303

*AE1 wireless power receive antenna shipped with DC2181

The manufacturers can be contacted at:

Inter-Technical	www.inter-technical.com , search for LTC4120
TDK	www.tdk.components.com
Würth	http://katalog.we-online.de/pbs/datasheet/760308101303.pdf

AE1 is physically mounted with double sided tape, as well as the electrical connection pins. Removing AE1 is likely to damage the ferrite on the backside of the antenna. Only remove AE1 when you have a suitable replacement at hand.

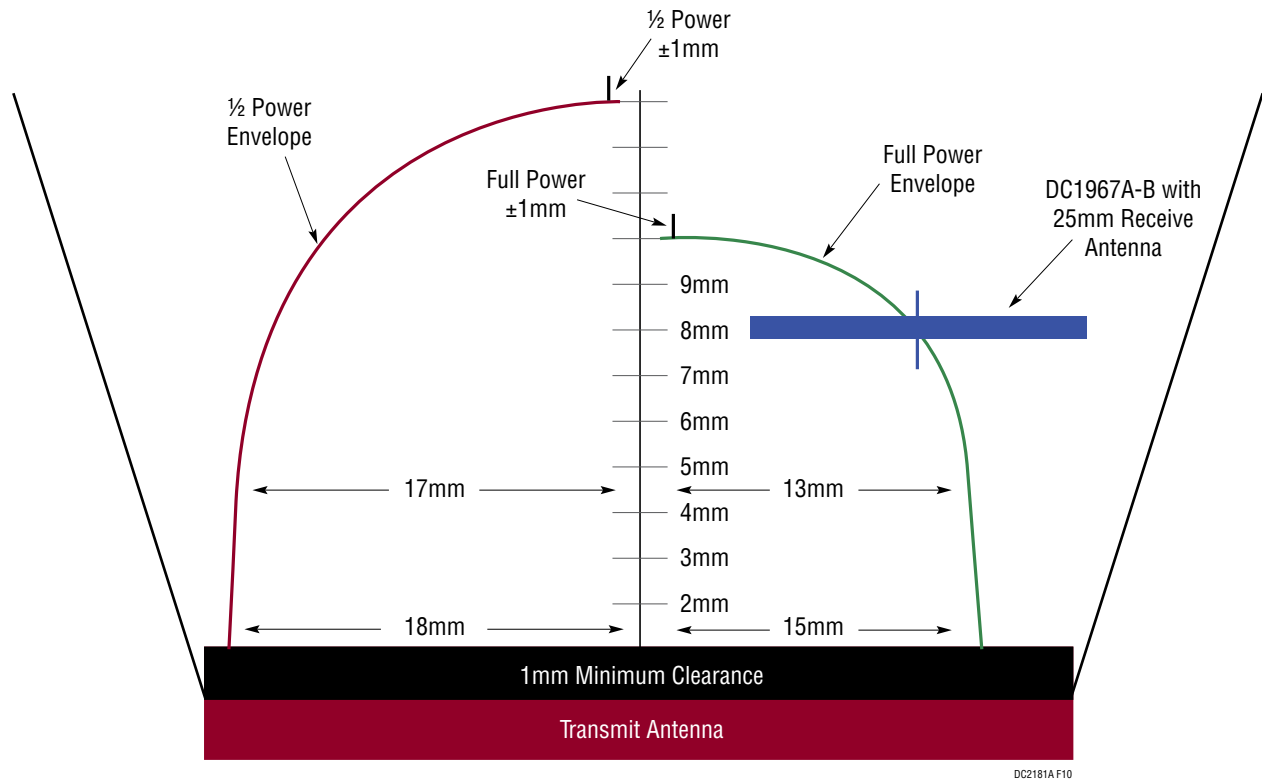

Figure 10. Power Transfer vs Axial Distance and Misalignment

DEMO MANUAL

DC2181A-A/B

PARTS LIST

ITEM	QTY	REFERENCE	PART DESCRIPTION	MANUFACTURER/PART NUMBER
DC2181A General Bill of Materials				
DC2181A Required Circuit Components				
1	1	AE1	RECEIVE ANTENNA	INTER-TECHNICAL, L41200R02
2	2	C2S1, C2P1	CAP, CHIP, COG, 0.0047 μ F, \pm 5%, 50V, 0805	MURATA, GRM2165C1H472JA01D
3	1	C2P2	CAP, CHIP, COG, 0.0018 μ F, \pm 5%, 50V, 0603	KEMET, C0603C182J5GAC7533
4	1	C2S2	CAP, CHIP, COG, 0.022 μ F, \pm 5%, 50V, 0805	MURATA, GRM21B5C1H223JA01L
5	1	C1	CAP, CHIP, X5R, 10 μ F, \pm 20%, 16V, 0805	TDK, C2012X5R1C106K
6	1	C2	CAP, CHIP, X5R, 47 μ F, \pm 10%, 16V, 1210	MURATA, GRM32ER61C476KE15L
7	1	C3	CAP, CHIP, X7R, 0.01 μ F, \pm 10%, 50V, 0603	TDK, C1608X7R1H103K
8	1	C4	CAP, CHIP, X5R, 2.2 μ F, \pm 20%, 6.3V, 0402	MURATA, GRM155R60J225ME15D
9	1	C5	CAP, CHIP, X7S, 10 μ F, \pm 20%, 50V, 1210	TDK, C3225X7S1H106M
10	3	D1, D2, D3	DIODE, SCHOTTKY, 40V, 2A, PowerDI123	DIODES, DFLS240L-7
11	1	L1	IND, SMT, 15 μ H, 260m Ω , \pm 20%, 0.86A, 4mm \times 4mm	COILCRAFT, LPS4018-153ML
12	1	R1	RES, CHIP, 1.40M, \pm 1%, 1/16W, 0402	VISHAY, CRCW04021M40FKED
13	1	R2	RES, CHIP, 412k Ω , \pm 1%, 1/16W, 0402	VISHAY, CRCW0402412KFKED
14	2	R3, R7	RES, CHIP, 10k Ω , \pm 1%, 1/16W, 0402	VISHAY, CRCW040210K0FKED
15	1	R5	RES, CHIP, 3.01k Ω , \pm 1%, 1/16W, 0402	VISHAY, CRCW04023K01FKED
16	1	R36	RES, CHIP, 0 Ω JUMPER, 1/16W, 0402	VISHAY, CRCW04020000Z0ED
Additional Demo Board Circuit Components				
1	3	C6, C8, C9	CAP, CHIP, X7R, 0.01 μ F, \pm 10%, 25V, 0402	TDK, C1005X7R1E103K
2	2	C7, C10	CAP, CHIP, X5R, 1 μ F, \pm 10%, 16V, 0402	TDK, C1005X5R1C105K
3	1	D4	DIODE, ZENER, 39V, \pm 5%, 1W, PowerDI123	DIODES, DFLZ39
4	8	D5, D6, D7, D8, D9, D10, D11, D12	DIODE, LED, GREEN, 0603	LITE-ON, LTST-C193KGKT-5A
5	1	R4	RES, CHIP, 2k Ω , \pm 5%, 1/16W, 0402	VISHAY, CRCW04022K00JNED
6	2	R11, R12	RES, CHIP, 100k Ω , \pm 5%, 1/16W, 0402	VISHAY, CRCW0402100KJNED
7	1	R13	RES, CHIP, 10k Ω , \pm 5%, 1/16W, 0402	VISHAY, CRCW040210K0JNED
8	2	R14, R35	RES, CHIP, 432 Ω , \pm 1%, 1/16W, 0402	VISHAY, CRCW0402432RFKED
9	2	R15, R33	RES, CHIP, 22.6k Ω , \pm 1%, 1/16W, 0402	VISHAY, CRCW040222K6FKED
10	1	R16	RES, CHIP, 34.8k Ω , \pm 1%, 1/16W, 0402	VISHAY, CRCW040234K8FKED
11	7	R17, R18, R19, R20, R21, R22, R23	RES, CHIP, 100k Ω , \pm 1%, 1/16W, 0402	VISHAY, CRCW0402100KFKED
12	1	R24	RES, CHIP, 49.9k Ω , \pm 1%, 1/16W, 0402	VISHAY, CRCW040249K9FKED
13	8	R25 TO R32	RES, CHIP, 1k Ω , \pm 5%, 1/16W, 0402	VISHAY, CRCW04021K00JNED
14	1	R34	RES, CHIP, 787k Ω , \pm 1%, 1/16W, 0402	VISHAY, CRCW0402787KFKED
15	2	R6, R38	RES, CHIP, 0 Ω JUMPER, 1/16W, 0402	VISHAY, CRCW04020000Z0ED
16	0	R8-OPT, R37-OPT	RES, CHIP, 0 Ω JUMPER, 1/16W, 0402	VISHAY, CRCW04020000Z0ED
17	2	U2, U3	ULTRALOW POWER QUAD COMPARATORS WITH REFERENCE, 5mm \times 4mm DFN16	LINEAR TECHNOLOGY, LTC1445CDHD

PARTS LIST

ITEM	QTY	REFERENCE	PART DESCRIPTION	MANUFACTURER/PART NUMBER
Hardware: For Demo Board Only				
1	4	E3, E4, E7, E8	TURRET, 0.091"	MILL-MAX, 2501-2-00-80-00-00-07-0
2	4	E1, E2, E5, E6	TURRET, 0.061"	MILL-MAX, 2308-2-00-80-00-00-07-0
3	2	J1, J2	HEADER, 1PIN, 0.020" x 0.020"	SAMTEC, TMM-101-02-L-S
4	0	J3-OPT	CONN, 3 PIN POLARIZED	HIROSE, DF3-3P-2DSA
5	2	BP1, BP2, BP3, BP4	CLEAR 0.200" x 0.440" BUMPER	KEYSTONE, 785-C
6	0.00058		3M, 0.5IN WIDE, 1/16IN THICK, DOUBLE SIDED FOAM TAPE, 0.75IN x 0.50IN PIECE	3M, 4466
7	4		STAND-OFF, NYLON, 0.375"	KEYSTONE, 8832

ITEM	QTY	REFERENCE	PART DESCRIPTION	MANUFACTURER/PART NUMBER
DC2181A-A Required Circuit Components				
1	0	R9	NO LOAD. SMD 0402	
2	1	R10	RES, CHIP, 0Ω JUMPER, 1/16W, 0402	VISHAY, CRCW04020000Z0ED
3	1	U1	400mA WIRELESS SYNCHRONOUS BUCK BATTERY CHARGER, 3mm x 3mm QFN16	LINEAR TECHNOLOGY, LTC4120EUD-4.2

ITEM	QTY	REFERENCE	PART DESCRIPTION	MANUFACTURER/PART NUMBER
DC2181A-B Required Circuit Components				
1	1	R9	RES, CHIP, 1.40M, ±1%, 1/16W, 0402	VISHAY, CRCW04021M40FKED
2	1	R10	RES, CHIP, 1.05M, ±1%, 1/16W, 0402	VISHAY, CRCW04021M05FKED
3	1	U1	400mA WIRELESS SYNCHRONOUS BUCK BATTERY CHARGER, 3mm x 3mm QFN16	LINEAR TECHNOLOGY, LTC4120EUD

DEMO MANUAL

DC2181A-A/B

PARTS LIST

ITEM	QTY	REFERENCE	PART DESCRIPTION	MANUFACTURER/PART NUMBER
DC1968A Bill of Materials				
DC1968A Required Circuit Components				
1	1	CX1, CX2	CAP, CHIP, PPS, 0.15 μ F, \pm 2%, 50V, 6mm \times 4.1mm	PANASONIC, ECHU1H154GX9
2	2	C4, C5	CAP, CHIP, X7R, 0.01 μ F, \pm 10%, 50V, 0402	MURATA, GRM155R71H103KA88D
3	1	C6	CAP, CHIP, X7R, 4.7 μ F, \pm 10%, 50V, 0402	MURATA, GRM31CR71H475KA12L
4	1	C7	CAP, CHIP, X5R, 0.068 μ F, \pm 10%, 50V, 0603	MURATA, GRM188R71H683K
5	1	C8	CAP, CHIP, C0G, 330pF, \pm 5%, 50V, 0402	TDK, C1005COG1H331J
6	1	C9	CAP, CHIP, X7R, 0.47 μ F, \pm 10%, 25V, 0603	MURATA, GRM188R71E474K
7	1	C10	CAP, CHIP, X5R, 22 μ F, \pm 20%, 6.3V, 0805	TAIYO-YUDEN, JMK212BJ226MG
8	2	D1, D4	DIODE, ZENER, 16V, 350mV, SOT23	DIODES, BZX84C16
9	2	D2, D3	DIODE, SCHOTTKY, 40V, 1A, 2DSN	ON SEMICONDUCTOR, NSR10F40NXT5G
10	1	D5	DIODE, SCHOTTKY, 40V, 2A, PowerDI123	DIODES, DFLS240L
11	2	L1, L2	IND, SMT, 68 μ H, 0.41A, 0.40 Ω , \pm 20%, 5mm \times 5mm	TDK, VLCF5028T-680MR40-2
12	1	L3	IND, SMT, 4.7 μ H, 1.6A, 0.125 Ω , \pm 20%, 4mm \times 4mm	COILCRAFT, LPS4018-472M
13	1	Lx	TRANSMIT COIL	TDK, WT-505060-8K2-LT
14	2	M1, M2	MOSFET, SMT, N-CHANNEL, 60V, 11m Ω , S08	VISHAY, Si4108DY-T1-GE3
15	1	M3	MOSFET, SMT, P-CHANNEL, -12V, 32m Ω , SOT23	VISHAY, Si2333DS
16	1	M4	MOSFET, SMT, N-CHANNEL, 60V, 7.5 Ω , 115mA, SOT23	ON SEMI, 2N7002L
17	2	R1, R2	RES, CHIP, 100 Ω , \pm 5%, 1/16W, 0402	VISHAY, CRCW0402100RJNED
18	2	R3, R8	RES, CHIP, 150k Ω , \pm 5%, 1/16W, 0402	VISHAY, CRCW0402150JNED
19	1	R4	RES, CHIP, 40.2k Ω , \pm 1%, 1/16W, 0402	VISHAY, CRCW040240K2FKED
20	1	R5	RES, CHIP, 20k Ω , \pm 1%, 1/16W, 0402	VISHAY, CRCW040220K0FKED
21	2	R6, R10	RES, CHIP, 100k Ω , \pm 1%, 1/16W, 0402	VISHAY, CRCW0402100KFKED
22	1	R7	RES, CHIP, 536k Ω , \pm 1%, 1/16W, 0402	VISHAY, CRCW0402536KFKED
23	1	U1	LT3480EDD, PMIC 38V, 2A, 2.4MHz STEP-DOWN SWITCHING REGULATOR WITH 70 μ A QUIESCENT CURRENT	LINEAR TECHNOLOGY, LT3480EDD
Additional Demo Board Circuit Components				
1	0	CX3-OPT, CX4-OPT	CAP, PPS, 0.15 μ F, 2.5%, 63VAC, MKS02	WIMA, MKS0D031500D00JSSD
2	1	D6	LED, GREEN, 0603	LITE-ON, LTST-C190KGKT
3	1	R9	RES, CHIP, 1k Ω , \pm 5%, 1/16W, 0402	VISHAY, CRCW04021K00JNED
Hardware: For Demo Board Only				
1	6	E1 TO E6	TURRET, 0.09 DIA	MILL-MAX, 2501-2-00-80-00-00-07-0
2	4		STAND-OFF, NYLON, 0.375"	KEYSTONE, 8832

SCHEMATIC DIAGRAM

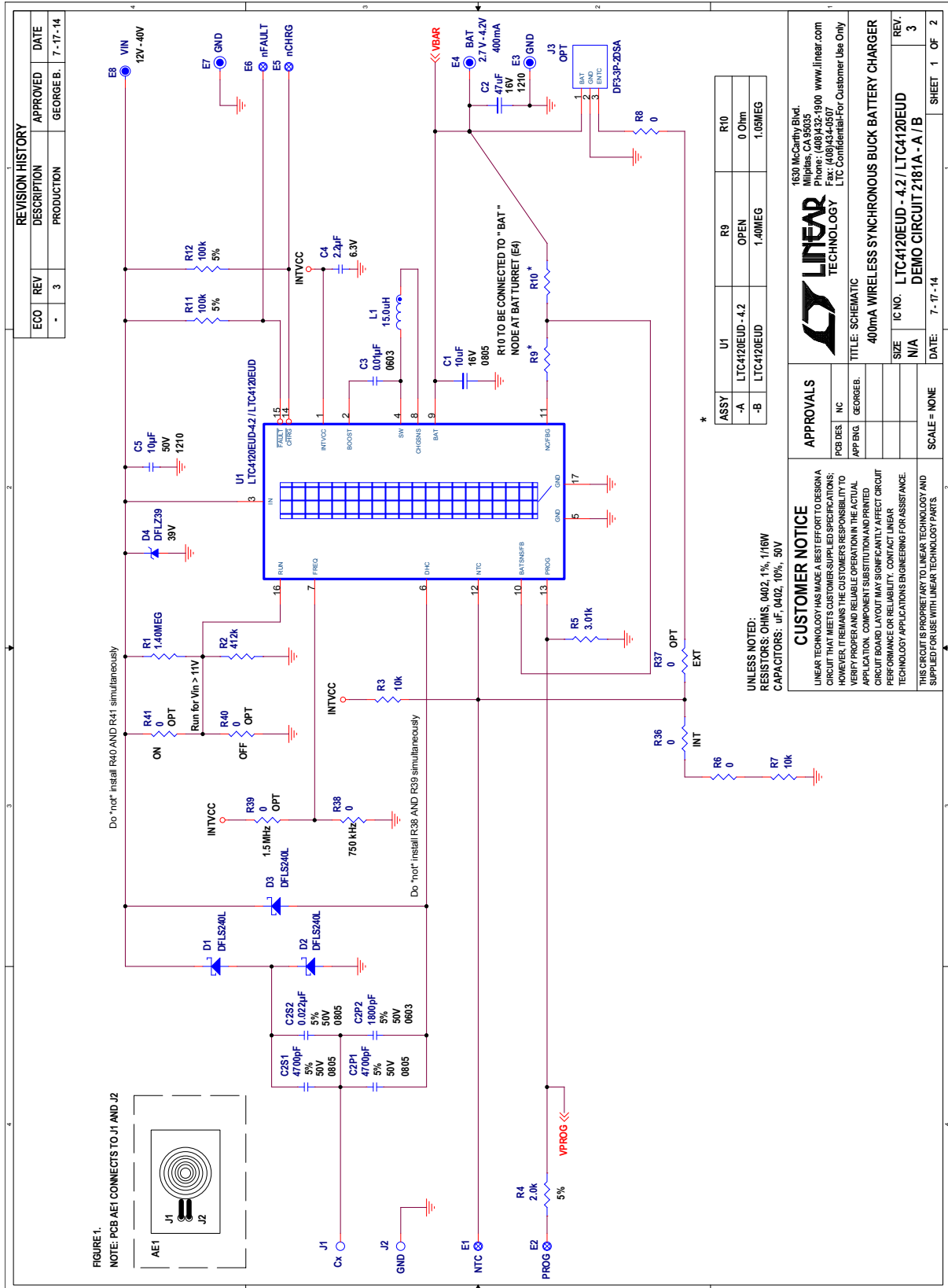

DEMO MANUAL DC2181A-A/B

SCHEMATIC DIAGRAM

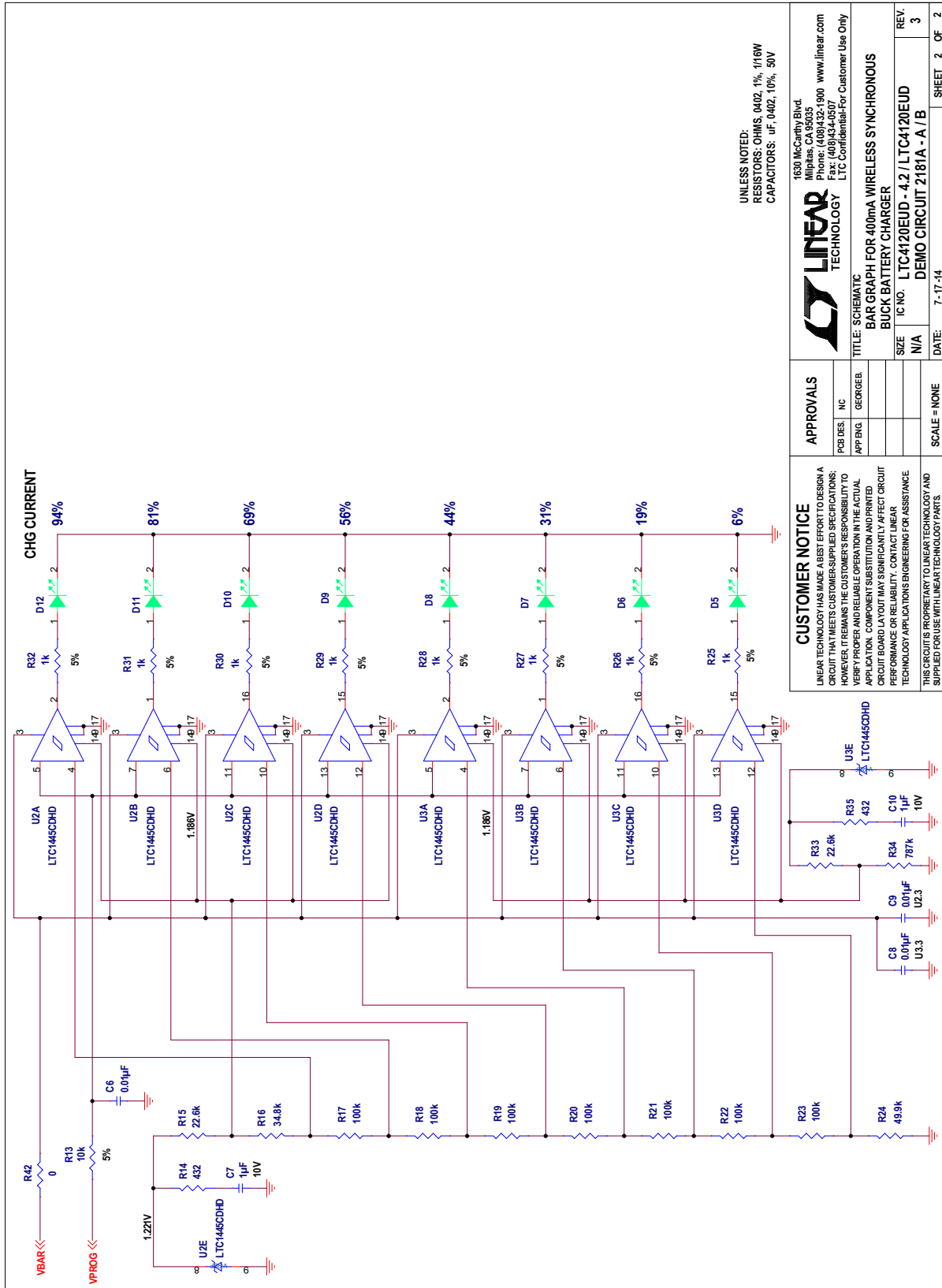

		1630 McCarthy Blvd. Milpitas, CA 95035 Phone: (408)432-1900 www.linear.com Fax: (408)432-0070 LTC Confidential-For Customer Use Only	
APPROVALS		TITLE: SCHEMATIC BAR GRAPH FOR 400mA WIRELESS SYNCHRONOUS BUCK BATTERY CHARGER	
PCB DES: NC	APP ENG: GEORGE.B.	SIZE: N/A	IC NO.: LTC4120EUD - 4.2 / LTC4120EUD
SCALE = NONE		DATE: 7-17-14	REV: 3
SHEET 2 OF 2		DEMO CIRCUIT 2181A - A / B	

CUSTOMER NOTICE

LINEAR TECHNOLOGY HAS MADE AN BEST EFFORT TO DESIGN A CIRCUIT THAT MEETS CUSTOMER-SUPPLIED SPECIFICATIONS; HOWEVER, IT REMAINS THE CUSTOMER'S RESPONSIBILITY TO VERIFY PROPER AND RELIABLE OPERATION IN THE ACTUAL APPLICATION. COMPONENT SUBSTITUTION AND PRINTED CIRCUIT BOARD LAYOUT MAY SIGNIFICANTLY AFFECT CIRCUIT PERFORMANCE OR RELIABILITY. CONTACT LINEAR TECHNOLOGY APPLICATIONS ENGINEERING FOR ASSISTANCE.

THIS CIRCUIT IS PROPRIETARY TO LINEAR TECHNOLOGY AND SUPPLIED FOR USE WITH LINEAR TECHNOLOGY PARTS.

SCHEMATIC DIAGRAM

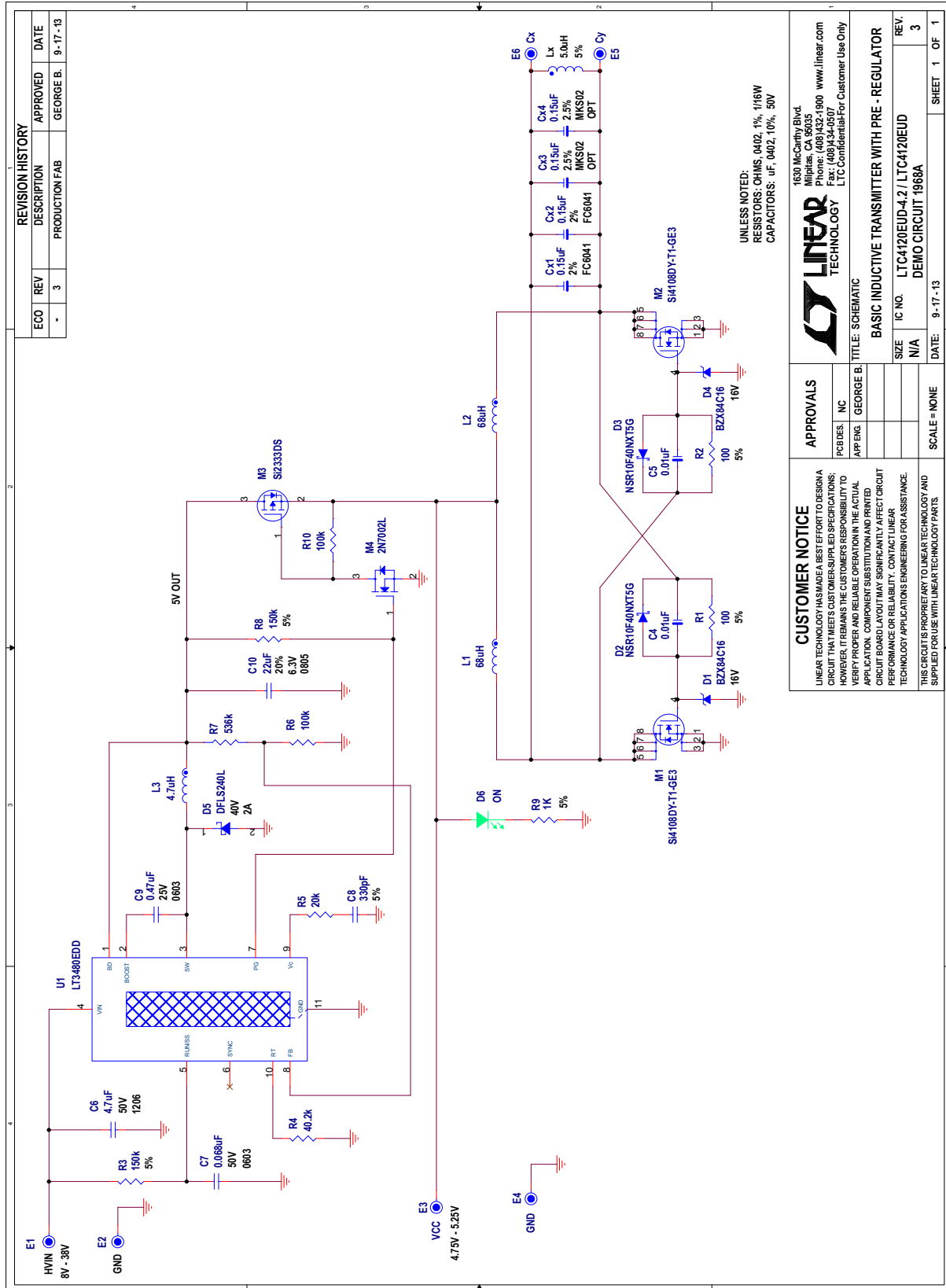

CUSTOMER NOTICE	LINEAR TECHNOLOGY HAS MADE A BEST EFFORT TO DESIGN A CIRCUIT THAT MEETS CUSTOMER SUPPLIED SPECIFICATIONS; HOWEVER, IT REMAINS THE CUSTOMER'S RESPONSIBILITY TO VERIFY PROPER AND RELIABLE OPERATION IN THE ACTUAL APPLICATION. COMPONENT SUBSTITUTION AND PRINTED CIRCUIT BOARD LAYOUT MAY SIGNIFICANTLY AFFECT CIRCUIT PERFORMANCE OR RELIABILITY. CONTACT LINEAR TECHNOLOGY APPLICATIONS ENGINEERING FOR ASSISTANCE.		
	THIS CIRCUIT IS PROPRIETARY TO LINEAR TECHNOLOGY AND SUPPLIED FOR USE WITH LINEAR TECHNOLOGY PARTS.		
APPROVALS	PCB DES: NC APP ENG: GEORGE B.		
SCALE	NONE		
DATE	9-17-13		
SIZE	N/A		
IC NO.	LTC4120EUD-4.2 / LTC4120EUD		
REV.	3		
REV. DEMO CIRCUIT	1968A		

1630 McCarthy Blvd.
Framingham, MA 01903-3000 www.linear.com
Phone: (408) 345-5070
Fax: (408) 345-0507
LTC Confidential-For Customer Use Only

TITLE: SCHEMATIC

BASIC INDUCTIVE TRANSMITTER WITH PRE-REGULATOR

DEMO MANUAL

DC2181A-A/B

The DC1968A Basic Wireless Transmitter is available from Linear Technology as part of the DC1969A-B Wireless Power Kit. To obtain the DC1968A Basic Wireless Transmitter, please order the DC1969A-B kit.

The ProxiPoint Transmitters are available from PowerByProxi: www.powerbyproxi.com/evaluation-kits/proxi-point/

DEMONSTRATION BOARD IMPORTANT NOTICE

Linear Technology Corporation (LTC) provides the enclosed product(s) under the following **AS IS** conditions:

This demonstration board (DEMO BOARD) kit being sold or provided by Linear Technology is intended for use for **ENGINEERING DEVELOPMENT OR EVALUATION PURPOSES ONLY** and is not provided by LTC for commercial use. As such, the DEMO BOARD herein may not be complete in terms of required design-, marketing-, and/or manufacturing-related protective considerations, including but not limited to product safety measures typically found in finished commercial goods. As a prototype, this product does not fall within the scope of the European Union directive on electromagnetic compatibility and therefore may or may not meet the technical requirements of the directive, or other regulations.

If this evaluation kit does not meet the specifications recited in the DEMO BOARD manual the kit may be returned within 30 days from the date of delivery for a full refund. THE FOREGOING WARRANTY IS THE EXCLUSIVE WARRANTY MADE BY THE SELLER TO BUYER AND IS IN LIEU OF ALL OTHER WARRANTIES, EXPRESSED, IMPLIED, OR STATUTORY, INCLUDING ANY WARRANTY OF MERCHANTABILITY OR FITNESS FOR ANY PARTICULAR PURPOSE. EXCEPT TO THE EXTENT OF THIS INDEMNITY, NEITHER PARTY SHALL BE LIABLE TO THE OTHER FOR ANY INDIRECT, SPECIAL, INCIDENTAL, OR CONSEQUENTIAL DAMAGES.

The user assumes all responsibility and liability for proper and safe handling of the goods. Further, the user releases LTC from all claims arising from the handling or use of the goods. Due to the open construction of the product, it is the user's responsibility to take any and all appropriate precautions with regard to electrostatic discharge. Also be aware that the products herein may not be regulatory compliant or agency certified (FCC, UL, CE, etc.).

No License is granted under any patent right or other intellectual property whatsoever. **LTC assumes no liability for applications assistance, customer product design, software performance, or infringement of patents or any other intellectual property rights of any kind.**

LTC currently services a variety of customers for products around the world, and therefore this transaction **is not exclusive**.

Please read the DEMO BOARD manual prior to handling the product. Persons handling this product must have electronics training and observe good laboratory practice standards. **Common sense is encouraged.**

This notice contains important safety information about temperatures and voltages. For further safety concerns, please contact a LTC application engineer.

Mailing Address:

Linear Technology
1630 McCarthy Blvd.
Milpitas, CA 95035

Copyright © 2004, Linear Technology Corporation