

FRDM-17C724-EVB Evaluation Board

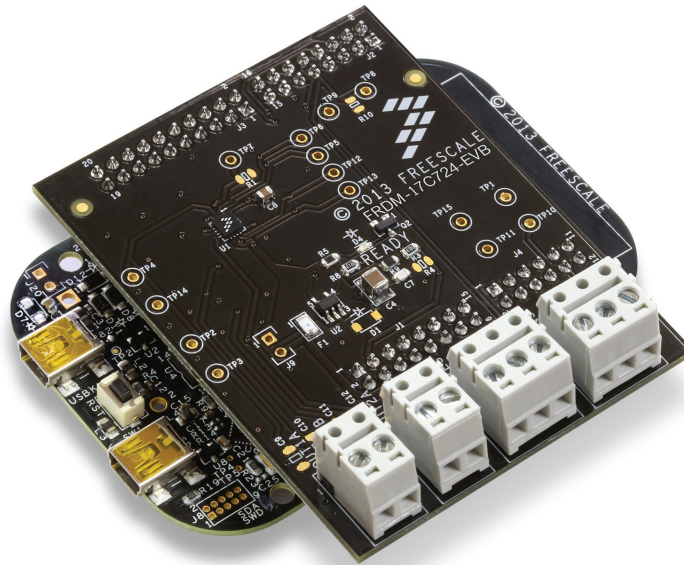

Figure 1. FRDM-17C724-EVB

Table of Contents

1 Important Notice	3
2 Getting Started	4
3 Getting to Know the Hardware	5
5 Installing the Software and Setting up the Hardware	11
6 Schematic	14
7 Silkscreen	15
8 Bill of Materials	16
9 References	17
10 Revision History	18

1 Important Notice

Freescale provides the enclosed product(s) under the following conditions:

This evaluation kit is intended for use of ENGINEERING DEVELOPMENT OR EVALUATION PURPOSES ONLY. It is provided as a sample IC pre-soldered to a printed circuit board to make it easier to access inputs, outputs, and supply terminals. This evaluation kit may be used with any development system or other source of I/O signals by simply connecting it to the host MCU or computer board via off-the-shelf cables. Final device in an application will be heavily dependent on proper printed circuit board layout and heat sinking design as well as attention to supply filtering, transient suppression, and I/O signal quality.

The goods provided may not be complete in terms of required design, marketing, and or manufacturing related protective considerations, including product safety measures typically found in the end product incorporating the goods. Due to the open construction of the product, it is the user's responsibility to take any and all appropriate precautions with regard to electrostatic discharge. In order to minimize risks associated with the customers applications, adequate design and operating safeguards must be provided by the customer to minimize inherent or procedural hazards. For any safety concerns, contact Freescale sales and technical support services.

Should this evaluation kit not meet the specifications indicated in the kit, it may be returned within 30 days from the date of delivery and will be replaced by a new kit.

Freescale reserves the right to make changes without further notice to any products herein. Freescale makes no warranty, representation or guarantee regarding the suitability of its products for any particular purpose, nor does Freescale assume any liability arising out of the application or use of any product or circuit, and specifically disclaims any and all liability, including without limitation consequential or incidental damages. "Typical" parameters can and do vary in different applications and actual performance may vary over time. All operating parameters, including "Typical", must be validated for each customer application by customer's technical experts.

Freescale does not convey any license under its patent rights nor the rights of others. Freescale products are not designed, intended, or authorized for use as components in systems intended for surgical implant into the body, or other applications intended to support or sustain life, or for any other application in which the failure of the Freescale product could create a situation where personal injury or death may occur.

Should the Buyer purchase or use Freescale products for any such unintended or unauthorized application, the Buyer shall indemnify and hold Freescale and its officers, employees, subsidiaries, affiliates, and distributors harmless against all claims, costs, damages, and expenses, and reasonable attorney fees arising out of, directly or indirectly, any claim of personal injury or death associated with such unintended or unauthorized use, even if such claim alleges that Freescale was negligent regarding the design or manufacture of the part. Freescale™ and the Freescale logo are trademarks of Freescale Semiconductor, Inc. All other product or service names are the property of their respective owners. © Freescale Semiconductor, Inc. 2014

2 Getting Started

2.1 Kit Contents/Packing List

The FRDM-17C724-EVB contents include:

- Assembled and tested evaluation board/module in an anti-static bag
- Quick Start Guide, Analog Tools
- Warranty card

2.2 Jump Start

Freescale's analog product development boards help to easily evaluate Freescale products. These tools support analog mixed signal and power solutions including monolithic ICs using proven high-volume SMARTMOS mixed signal technology, and system-in-package devices utilizing power, SMARTMOS and MCU dies. Freescale products enable longer battery life, smaller form factor, component count reduction, ease of design, lower system cost and improved performance in powering state of the art systems.

- Go to www.freescale.com/analogtools
- Locate your kit
- Review your Tool Summary Page
- Look for



- Download documents, software, and other information

Once the files are downloaded, review the user guide JumpStart. The user guide includes setup instructions, BOM and schematics. Jump start bundles are available on each tool summary page with the most relevant and current information. The information includes everything needed for design.

2.3 Required Equipment and Software

To use this kit, you need:

- DC Power supply (2.7 V to 5.5 V, 0.1 A to 0.4 A, depending on stepper motor requirements)
- USB A to mini-B cable
- Oscilloscope (preferably 4-channel) with current probe(s)
- Digital multimeter
- FRDM-KL25Z Freedom Development Platform
- Typical loads (stepper motor, brushed DC motors, or power resistors)
- 3/16" blade screwdriver
- One 12-pin (PPTC062LFBN-RC), two 16-pin (PPTC082LFBN-RC), and one 20-pin (PPTC102LFBN-RC) female connector, by Sullins Connector Solutions, or equivalent soldered to FRDM-KL25Z

2.4 System Requirements

The kit requires the following:

- USB-enabled PC with Windows® XP or higher

3 Getting to Know the Hardware

3.1 Board Overview

The FRDM-17C724-EVB evaluation board features the MPC17C724 dual H-Bridge IC, which features the ability to drive either a single two phase stepper motor or two brushed DC motors. The MPC17C724 incorporates internal control logic, a charge pump, gate drive, and high current, low $R_{DS(on)}$ MOSFET output circuitry.

3.2 Board Features

The FRDM-17C724-EVB evaluation board is designed to easily evaluate and test the main component, the MPC17C724. The board's main features are as follows:

- Compatible with Freedom series evaluation boards such as FRDM-KL25Z
- Built in fuse for both part and load protection
- Screw terminals to provide easy connection of power and loads
- Test points to allow probing of signals
- Built in voltage regulator to supply logic level circuitry
- LED to indicate status of Logic power supply of the evaluation board, as well as a general purpose indicator

3.3 FRDM-KL25Z Features

The FRDM-KL25Z board features are as follows:

- MKL25Z128VLK4 MCU - 48 MHz, 128 KB Flash, 16 KB SRAM, USB OTG (FS), 80LQFP
- Capacitive touch slider, MMA8451Q accelerometer, tri-color LED
- Flexible power supply options - USB, coin cell battery, external source
- Easy access to MCU I/O
- Battery-ready, power-measurement access points
- Form factor compatible with Arduino™ R3 pin layout
- New, OpenSDA debug interface
- Mass storage device flash programming interface (default) - no tool installation required to evaluate demonstration applications
- P&E Debug interface provides run-control debugging and compatibility with IDE tools
- CMSIS-DAP interface: new ARM standard for embedded debug interface

Additional reference documents are available on freescale.com/FRDM-KL25Z.

3.4 Device Features

This evaluation board features the following Freescale product:

Table 1. Device Features

Device	Description	Features
MPC17C724	The MPC17C724 is a dual H-Bridge motor driver IC intended for operating stepper motors	<ul style="list-style-type: none"> • Voltage range of operation from 2.7 V to 5.5 V • Output Current of 0.4 A (DC) continuous, 0.8 A peak • 1.0 Ω $R_{DS(on)}$ H-Bridge MOSFET outputs • 3.3/5.0 V TTL/CMOS compatible inputs • PWM frequencies up to 200 kHz • Undervoltage shutdown • Cross conduction (shoot through) suppression

3.5 Board Description

This evaluation board consists mainly of an MPC17C724. The following sections describe the additional hardware used to support the dual H-Bridge driver.

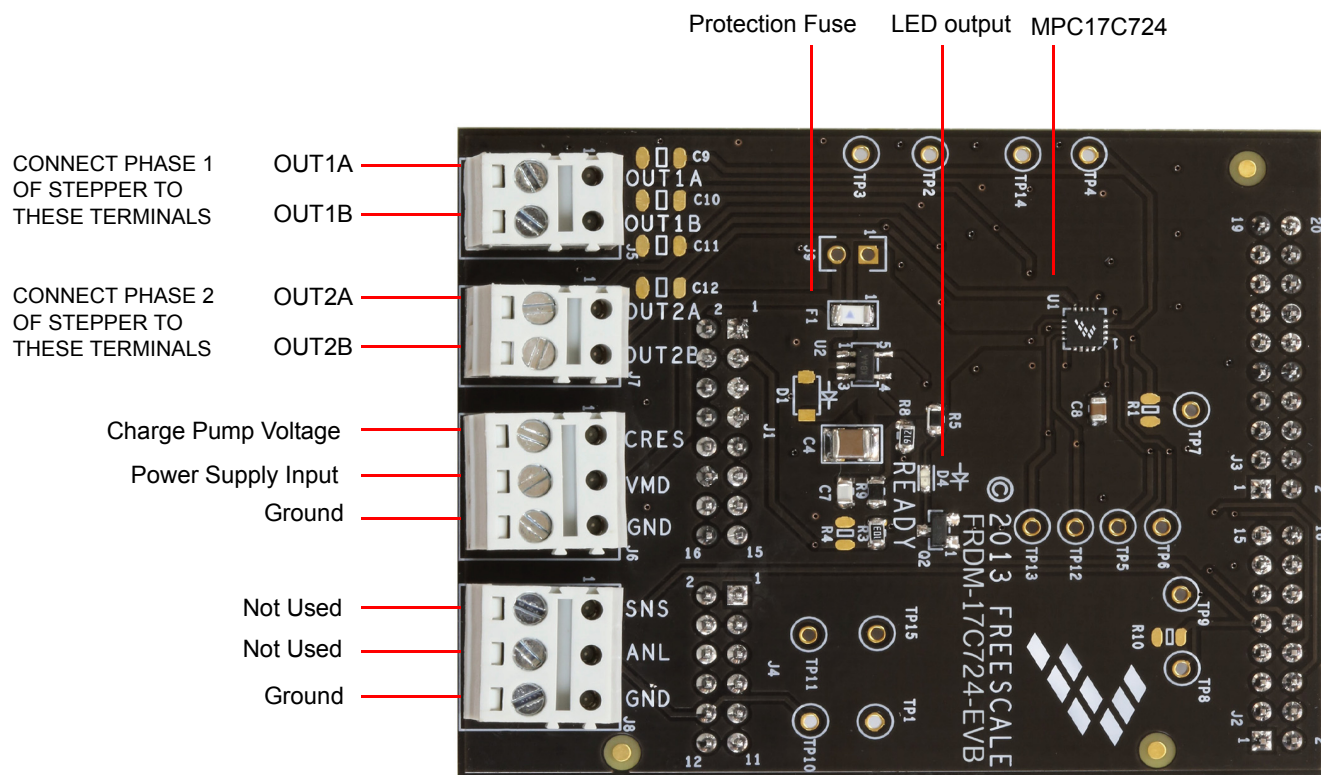

Figure 2. Board Description

Table 2. Board Description

Name	Description
U1	MPC17C724 H-Bridge motor drive IC
F1	Over current Protection Fuse
D4	User defined LED output
OUT1A	Output 1A Connect motor phase 1 lead to this terminal
OUT1B	Output 1B Connect motor phase 1 lead to this terminal
OUT2A	Output 2A Connect motor phase 2 lead to this terminal
OUT2B	Output 2B Connect motor phase 2 lead to this terminal
CRES	Charge Pump Voltage
VM	Power Supply Input
GND	Ground Terminal
SNS	Not used – connection to FRDM-KL25Z input
ANL	Not used – connection to FRDM-KL25Z input
GND	Ground Terminal

3.6 LED Display

An LED is provided as a visual output device for the FRDM-17C724-EVB evaluation board:

Table 3. Board Description

Name	Description
LED1 (D4 board designator)	Illuminated with an output from the FRDM-KL25Z. Note the on board voltage regulator must be operating for the LED to operate

3.7 Test Point Definitions

The following test-points provide access to signals on the FRDM-17C724-EVB. These signals are:

Table 4. Test Point Definitions

TP#	Signal Name	Description
TP1	GND	Ground
TP2	OUT2A	H-Bridge 2 Output A
TP3	OUT2B	H-Bridge 2 Output B
TP4	OUT1A	H-Bridge 1 Output A
TP5	IN1A	H-Bridge 1 Input A
TP6	IN1B	H-Bridge 1 Input B
TP7	PSAVE	Standby/Enable pin
TP8	READY	Logic signal from microcontroller. This signal causes the green LED to operate
TP9	SNSIN	Not Used
TP10	ANLIN	Not Used
TP11	VDDPWRGOOD	Signal to the Microcontroller indicating the voltage regulator is operating (3.3 V)
TP12	IN2A	H-Bridge 2 Input A
TP13	IN2B	H-Bridge 2 Input B
TP14	OUT1B	H-Bridge 1 Output B
TP15	VDD	Logic Power Supply from the voltage regulator on the evaluation board

3.8 Input Signal Definitions

The MPC17C724 IC has five input signals that are used to control certain outputs or functions inside the circuit. These signals are:

Table 5. Input Signal Definitions

Name	Description
IN1A	Controls OUT1A
IN1B	Controls OUT1B
IN2A	Controls OUT2A
IN2B	Controls OUT2B
PSAVE	Enables Outputs 1A, 1B and Outputs 2A, 2B

3.9 Output Signal Definitions

The MPC17C724 IC has four output signals used to drive a 2 phase stepper motor. These signals are:

Table 6. Output Signal Definitions

Name	Description
OUT1A	Output A of H-Bridge 1
OUT1B	Output B of H-Bridge 1
OUT2A	Output A of H-Bridge 2
OUT2B	Output B of H-Bridge 2

3.10 Screw Terminal Connections

There are four connectors on the FRDM-17C724-EVB which provide connections to the following signals:

Table 7: Screw Terminal Connections

Name	Signal	Signal Description
J5	OUT1A	H-Bridge 1 output A
	OUT1B	H-Bridge 1 output B
J6	CRES	Charge pump voltage for H-Bridge gate drive
	VM	Motor supply input (this is also the supply for the on board voltage regulator)
	GND	Primary ground connection for the motor power supply
J7	OUT2A	H-Bridge 2 output A
	OUT2B	H-Bridge 2 output B
J8	SNS	Not Used
	ANL	Not Used
	GND	Additional ground

3.11 Jumper J9

The FRDM-17C724-EVB has provision (not populated) for a jumper to accommodate measuring the total current consumption. If the fuse is bypassed, use extreme care to make sure the maximum current for the MPC17C724 is not exceeded (0.4 A continuous, 0.8 A peak/transients).

4 FRDM-KL25Z Freedom Development Platform

The Freescale Freedom development platform is a set of software and hardware tools for evaluation and development. It is ideal for rapid prototyping of microcontroller-based applications. The Freescale Freedom KL25Z hardware, FRDM-KL25Z, is a simple, yet sophisticated design featuring a Kinetis L Series microcontroller, the industry's first microcontroller built on the ARM[®] Cortex™-M0+ core.

4.1 Connecting FRDM-KL25Z to the Board

The FRDM-17C724-EVB kit may be used with many of the Freedom platform evaluation boards featuring Kinetis processors. The FRDM-KL25Z evaluation board has been chosen specifically to work with the FRDM-17C724-EVB kit because of its low cost and features. The FRDM-KL25Z board makes use of the USB, built in LEDs, and I/O ports available with Freescale's Kinetis KL2x family of microcontrollers. The main functions provided by the FRDM-KL25Z are to allow control of a stepper motor using a PC computer over USB, and to drive the necessary inputs on the FRDM-17C724-EVB evaluation kit to operate the motor.

The FRDM-17C724-EVB is connected to the FRDM-KL25Z using four dual row headers. The connections are as follows:

Table 8: FRDM-17C724-EVB to FRDM-KL25Z Connections

FRDM-17C724-EVB		FRDM-KL25Z		Pin Hardware Name		Description
Header	Pin	Header	Pin	FRDM-17C724-EVB	FRDM-KL25Z	
J1	1	J9	1	RUNPWRGD	PTB8	Regulator voltage present
J1	2	J9	2	N/C	SDA_PTD5	No connection
J1	3	J9	3	GND	PTB9	System Ground
J1	4	J9	4	N/C	P3V3	No connection
J1	5	J9	5	GND	PTB10	System ground
J1	6	J9	6	N/C	RESET/PTA20	No connection
J1	7	J9	7	GND	PTB11	System ground
J1	8	J9	8	N/C	P3V3	No connection
J1	9	J9	9	N/C	PTE2	No Connection
J1	10	J9	10	N/C	P5V_USB	No connection
J1	11	J9	11	N/C	PTE3	No connection
J1	12	J9	12	GND	GND	System ground
J1	13	J9	13	N/C	PTE4	No connection
J1	14	J9	14	N/C	GND	No connection
J1	15	J9	15	N/C	PTE5	No connection
J1	16	J9	16	N/C	P5-9V_VIN	No connection
J2	1	J1	1	EN	PTC7	Enable
J2	2	J1	2	N/C	PTA1	No connection
J2	3	J1	3	N/C	PTC0	No connection
J2	4	J1	4	N/C	PTD4	No connection
J2	5	J1	5	N/C	PTC3	No connection
J2	6	J1	6	IN1A	PTD4	Input 1A
J2	7	J1	7	N/C	PTC4	No connection
J2	8	J1	8	IN1B	PTA12	Input 1B
J2	9	J1	9	READY	PTC5	No connection green LED (from KL25Z)
J2	10	J1	10	IN2A	PTA4	No connection
J2	11	J1	11	READY	PTC6	Not used

Table 8: FRDM-17C724-EVB to FRDM-KL25Z Connections (continued)

FRDM-17C724-EVB		FRDM-KL25Z		Pin Hardware Name		Description
Header	Pin	Header	Pin	FRDM-17C724-EVB	FRDM-KL25Z	
J2	12	J1	12	IN2B	PTA5	No connection
J2	13	J1	13	N/C	PTC10	No connection
J2	14	J1	14	N/C	PTC8	No connection
J2	15	J1	15	N/C	PTC11	No connection
J2	16	J1	16	N/C	PTC9	No connection
J3	1	J2	1	N/C	PTC12	No connection
J3	2	J2	2	N/C	PTA13	No connection
J3	3	J2	3	N/C	PTC13	No connection
J3	4	J2	4	N/C	PTD5	No connection
J3	5	J2	5	N/C	PTC16	No connection
J3	6	J2	6	N/C	PTD0	No connection
J3	7	J2	7	N/C	PTC17	No connection
J3	8	J2	8	N/C	PTD2	No connection
J3	9	J2	9	N/C	PTA16	No connection
J3	10	J2	10	N/C	PTD3	No connection
J3	11	J2	11	N/C	PTA17	No connection
J3	12	J2	12	N/C	PTD1	No connection
J3	13	J2	13	N/C	PTE31	No connection
J3	14	J2	14	N/C	GND	No connection
J3	15	J2	15	N/C	N/C	No connection
J3	16	J2	16	N/C	VREFH	No connection
J3	17	J2	17	N/C	PTD6	No connection
J3	18	J2	18	N/C	PTE0	No connection
J3	19	J2	19	N/C	PTD7	No connection
J3	20	J2	20	N/C	PTE1	No connection
J4	1	J10	1	N/C	PTE20	No connection
J4	2	J10	2	N/C	PTB0	No connection
J4	3	J10	3	N/C	PTE21	No connection
J4	4	J10	4	N/C	PTB1	No connection
J4	5	J10	5	N/C	PTE22	No connection
J4	6	J10	6	N/C	PTB2	No connection
J4	7	J10	7	N/C	PTE23	No connection
J4	8	J10	8	N/C	PTB3	No connection
J4	9	J10	9	N/C	PTE29	No connection
J4	10	J10	10	ANLIN	PTC2	Not used
J4	11	J10	11	N/C	PTE30	No connection
J4	12	J10	12	N/C	PTC1	No connection

5 Installing the Software and Setting up the Hardware

5.1 Installing the Motor Control Graphical User Interface (GUI) on your Computer

The latest version of the Motor Control GUI is designed to run on any Windows 8, Windows 7, Vista, or XP-based operating system. To install the software, go to www.freescale.com/analogtools and select your kit. Click on that link to open the corresponding Tool Summary Page. Look for "Jump Start Your Design". Download to your computer desktop the Motor Control GUI software.

Run the install program from the desktop. The Installation Wizard will guide you through the rest of the process.

To use the Motor Control GUI, go to the Windows Start menu, then Programs, then Motor Control GUI, and click on the Freescale icon. The Motor Control Graphic User Interface (GUI) will appear. The GUI is shown in Figure 3. The hex address numbers at the top are loaded with the vendor ID for Freescale (0x15A2), and the part ID (0x138). The left side panel displays these numbers only if the PC is communicating with the FRDM-KL25Z via the USB interface.

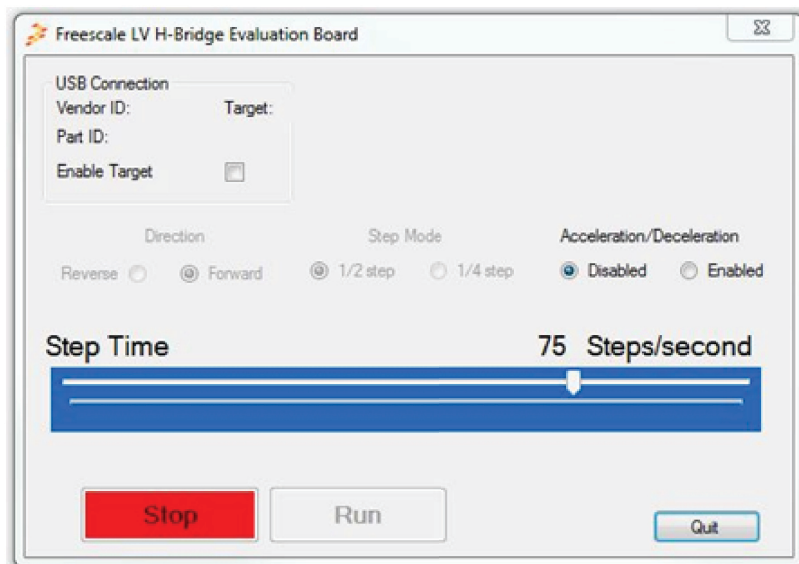

Figure 3. Motor Control GUI

5.2 Configuring the Hardware

Figure 4 shows the configuration diagram for FRDM-17C724-EVB.

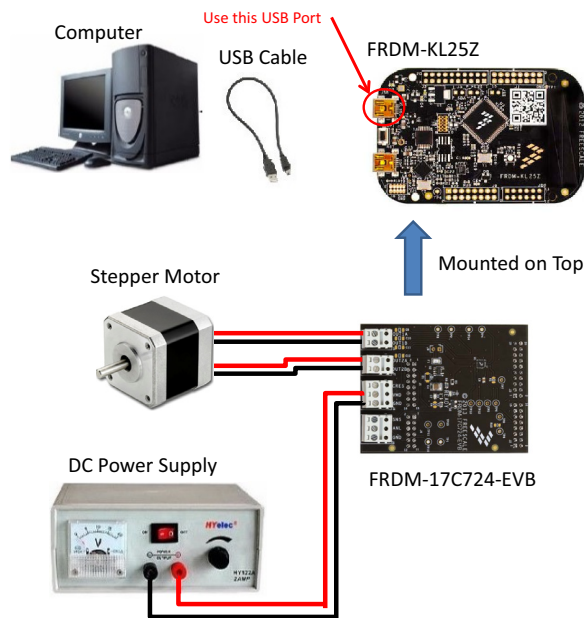

Figure 4. FRDM-17C724-EVB plus FRDM-KL25Z Board Setup

5.2.1 Step-by-step Instructions for Setting Up the Hardware Using Motor Control GUI

When using the FRDM-17C724-EVB make sure that the following operating parameters are followed or damage may occur.

- The maximum motor supply voltage (VM) cannot exceed 5.5 V, and must be at least 3.3 V
- The nominal operating current of the stepper motor cannot exceed 0.4 A (0.8 A peak)

In order to perform the demonstration example, first set up the evaluation board hardware and software as follows:

1. Setup the FRDM-KL25Z to accept code from the mbed online compiler. mbed is a developer site for ARM based microcontrollers. The instructions are at mbed.org (<https://mbed.org/handbook/mbed-FRDM-KL25Z-Upgrade>) (you will need to switch to the other USB port on the FRDM-KL25Z, and back after you load the project).
2. Go to the Freescale page on mbed.org and look for the repository named "LVHB DC Motor Drive". (<http://developer.mbed.org/teams/Freescale/code/LVHB-Stepper-Motor-Drive/>) Save the compiled code on your local drive, and then drag and drop it onto the mbed drive (which is the FRDM-KL25Z). Move the USB connector back to the other USB port on the FRDM-KL25Z.
Note: You may be asked to create a user before you can download the code.
3. Connect the FRDM-17C724-EVB to the FRDM-KL25Z. This is best accomplished by soldering the female connectors to the FRDM-KL25Z, and then connecting to the male pins provided on the FRDM-17C724-EVB.
4. Ready the computer, install the "Stepper Motor Driver GUI Software" (See [Section 5.1](#)).
5. Attach DC power supply (without turning on the power) to the VM and GND terminals.
6. Attach one set of coils of the stepper motor to the OUT 1A and OUT 1B output terminals. Attach the other phase coil of the stepper motor to terminals OUT2A and OUT2B. Launch the "Stepper Motor Driver GUI Software".
7. Make sure the GUI recognizes the FRDM-KL25Z. This is determined by seeing the hex Vendor ID (0x15A2), and Part ID (0x138) under USB connection in the upper left hand corner of the GUI. If the GUI does not recognize the FRDM-KL25Z, you need to disconnect and reconnect the USB cable to the FRDM-KL25Z.
8. Turn on the DC power supply.

9. Click on the "Enable Target" checkbox on the GUI. The demo is now ready to run.
10. Click the "Run" button to run the motor. Notice that some options of the GUI are disabled while the motor is running. To make changes, click the "Stop" button on the GUI, make the desired changes, and then click "Run" on the GUI to continue.
11. When finished, click "Enable Target" button on the GUI, and then "Quit". Turn off DC power supply. Remove USB cable.

6 Schematic

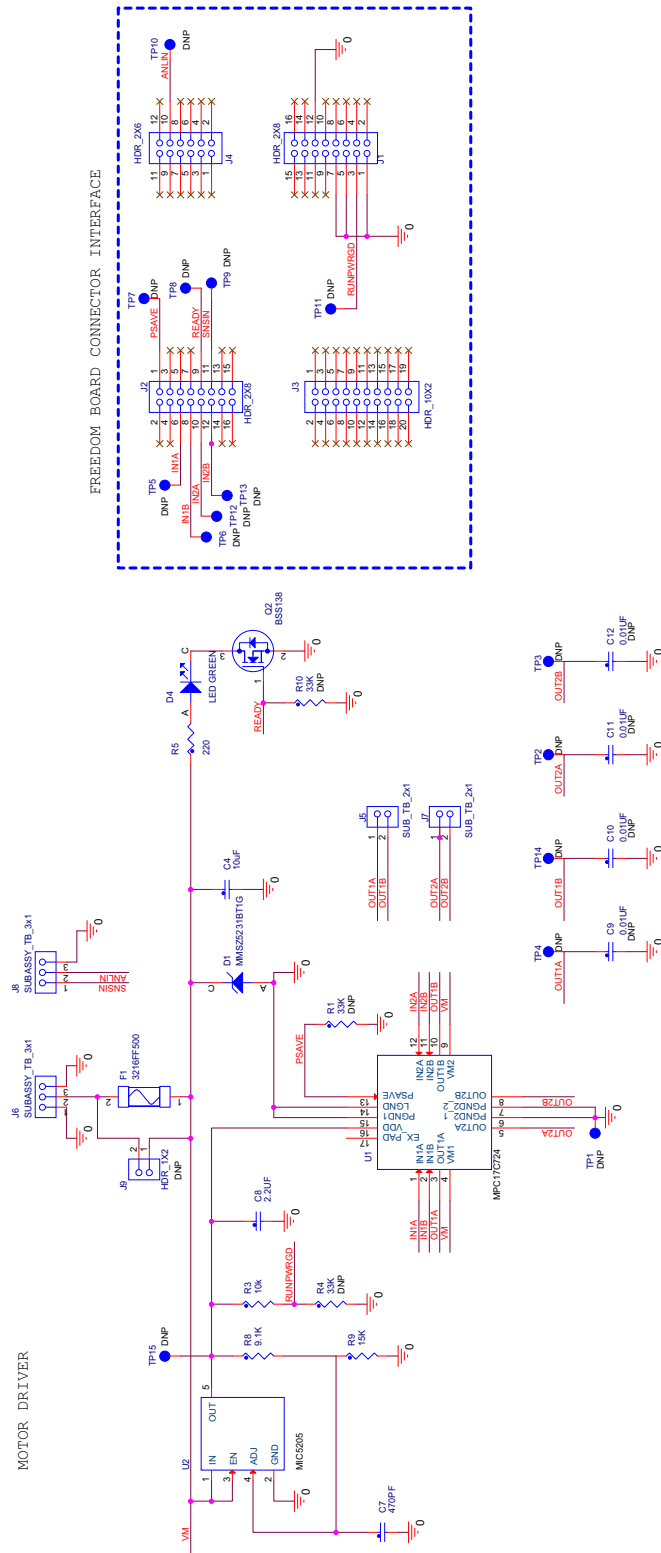
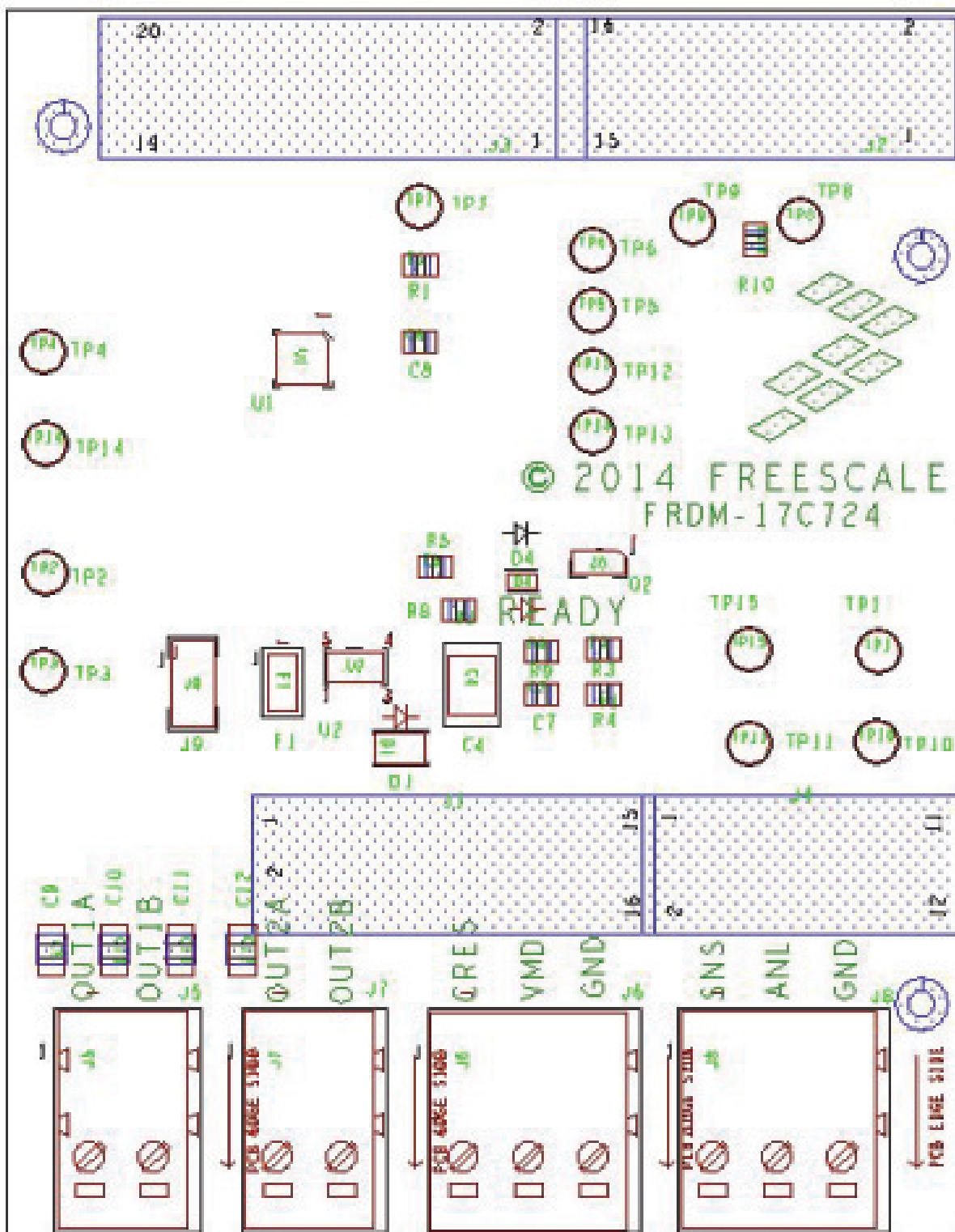

Figure 5. Schematic

7 Silkscreen

7.1 Silkscreen Top



8 Bill of Materials

Table 9. Bill of Materials ⁽¹⁾

Item	Qty	Schematic Label	Value	Description	Part Number	Assy Opt
Active Components						
1	1	U1	TSSOP24	H-Bridge motor driver	MPC17C724EP	(2)
Other Components						
2	1	U2	SOT23-5	Linear Reg LDO 1.5 V to 15 V 150 MA 2.5 V to 16 V	MIC5205	(2)
Transistors						
3	2	Q1, Q2	SOT-23	Transistor NMOS 50 V 220 MA	BSS138	
Diodes						
4	1	D1	SOD123	Diode Zener – 6.2 V 0.5 W	MMSZ5234B	
LEDs						
5	1	D4	0603	LED Green Single 20 MA	LG L29K-G2J1-24-Z	
Capacitors						
6	3	C1, C2, C3	0.1 uF	Ceramic 0.1 μ F 50 V 10% X7R	0805	
7	1	C4	10 uF	Ceramic 10 μ F 35 V 10% X7R	1210	
8	1	C8	2.2 uF	Ceramic 2.2 μ F 16 V 10% X7R	0805	
9	1	C7	470 pF	Ceramic 470 pF 50 V 5% COG	0805	
Fuses						
10	1	F1	1.25 A	Fuse Fast 1.25 A 63 V SMT		
Resistors						
11	1	R3	10 k	Metal Film 10 k 1/10 W 1%	0805	
12	1	R5	220	Metal Film 220 Ω 1/8 W 1%	0805	
13	1	R8	9.1 k	Metal Film 9.1 k 1/10 W 1%	0805	
14	1	R9	15 k	Metal Film 15 k 1/8 W 5%	0805	
Connectors						
15	2	J1, J2		HDR 2X8 TH 100MIL CTR TSW-108-07-G-D SAMTEC	HDR 2X8	
16	1	J3		HDR 2X10 TH 100MIL CTR TSW-110-07-S-D SAMTEC	HDR 2X10	
17	1	J4		HDR 2X6 TH 100MIL CTR TSW-106-07-S-D SAMTEC	HDR 2X6	
18	2	J5, J7		SUBASSEMBLY CON 1X3 TB TH 3.81MM SP 201H -- 138L + TERM BLOCK PLUG 3.81MM 2POS 210-80097, 210-80098	TERM BLOCK 1x2	
19	2	J6, J8		SUBASSEMBLY CON 1X3 TB TH 3.81MM SP 201H -- 138L + TERM BLOCK PLUG 3.81MM 3POS 210-80099, 211-79220	TERM BLOCK 1x3	

Notes:

1. Freescale does not assume liability, endorse, or warrant components from external manufacturers that are referenced in circuit drawings or tables. While Freescale offers component recommendations in this configuration, it is the customer's responsibility to validate their application.
2. **Critical components.** For critical components, it is vital to use the manufacturer listed.

9 References

Following are URLs where you can obtain information on related Freescale products and application solutions:

Freescale.com Support Pages	Description	URL
FRDM-17C724-EVB	Tool Summary Page	http://www.freescale.com/webapp/sps/site/prod_summary.jsp?code=FRDM-17C724-EVB
MPC17C724	Product Summary Page	http://www.freescale.com/webapp/sps/site/prod_summary.jsp?code=MPC17C724
FRDM-KL25Z	Freescale Development Platform	http://www.freescale.com/webapp/sps/site/prod_summary.jsp?code=FRDM-KL25Z
	Analog Home Page	http://freescale.com/analog
	mbed Home Page	http://www.mbed.org

9.1 Support

Visit www.freescale.com/support for a list of phone numbers within your region.

9.2 Warranty

Visit www.freescale.com/warranty for a list of phone numbers within your region.

10 Revision History

Revision	Date	Description of Changes
1.0	11/2014	• Initial Release



How to Reach Us:

Home Page:
freescale.com

Web Support:
freescale.com/support

Information in this document is provided solely to enable system and software implementers to use Freescale products. There are no express or implied copyright licenses granted hereunder to design or fabricate any integrated circuits based on the information in this document.

Freescale reserves the right to make changes without further notice to any products herein. Freescale makes no warranty, representation, or guarantee regarding the suitability of its products for any particular purpose, nor does Freescale assume any liability arising out of the application or use of any product or circuit, and specifically disclaims any and all liability, including without limitation consequential or incidental damages. "Typical" parameters that may be provided in Freescale data sheets and/or specifications can and do vary in different applications, and actual performance may vary over time. All operating parameters, including "typicals," must be validated for each customer application by customer's technical experts. Freescale does not convey any license under its patent rights nor the rights of others. Freescale sells products pursuant to standard terms and conditions of sale, which can be found at the following address: freescale.com/SalesTermsandConditions.

Freescale and the Freescale logo are trademarks of Freescale Semiconductor, Inc., Reg. U.S. Pat. & Tm. Off. SMARTMOS is a trademark of Freescale Semiconductor, Inc. All other product or service names are the property of their respective owners.

© 2014 Freescale Semiconductor, Inc.

Document Number: KTFRDM17C724UG
Rev. 1.0
11/2014

