

WPR1500-BUCK MP Receiver Reference Design User's Guide

1 Introduction

This document describes how to use the WPR1500-BUCK medium power receiver reference board designed by Freescale. It supports 15 W, is compliant with the WPC MPWG specifications, and has the capability to support future standards. It is a low-cost reference solution that can be easily customized using the FreeMASTER tool.

Contents

1. Introduction	1
2. System features	2
3. Package checklist	2
4. System block diagram	2
5. Hardware description	3
6. Getting started	4
7. References	18
8. Revision history	18



Figure 1. WPR1500 Reference Board – BUCK

2 System features

The WPR1500 medium power receiver reference board has the following features:

- Reference design compliant with medium power WPC Qi specifications
- Input power of 3.5 V ~ 20 V AC in peak from the transmitter via the receiver coil
- Output power of 15 W (5 V @ 3 A)
- Support of FSK communication signals from medium power transmitter
- Hardware protection of rectifier voltage, output voltage and output current
- Small PCB size (40 mm × 40 mm)
- FreeMASTER tool to enable customization and calibration

3 Package checklist

Table 1. Package checklist

Name	Count
WPR1500-BUCK board	1
WPR1500 debug board	1
10-pin SWD debug cable	1

4 System block diagram

The WPR1500 mediummedium power power receiver wireless charging system is shown in Figure 2.

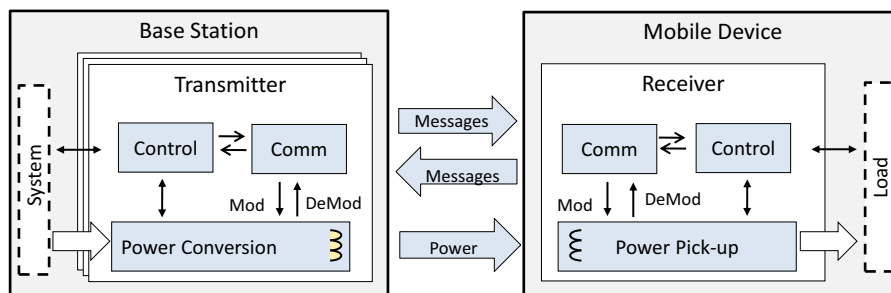

Figure 2. Wireless charging system overview

For the WPC Qi information visit www.wirelesspowerconsortium.com/developers/

5 Hardware description

5.1 Reference board block diagram

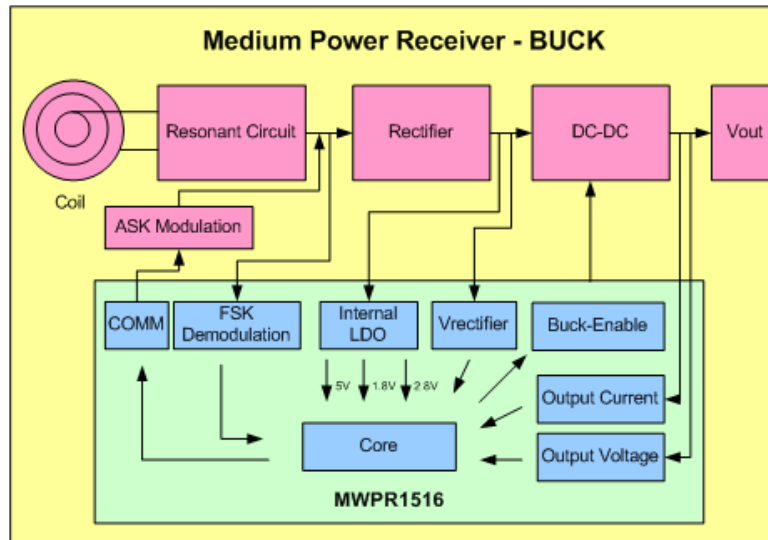

Figure 3. WPR1500 receiver board block diagram – BUCK

5.2 Modules explanation

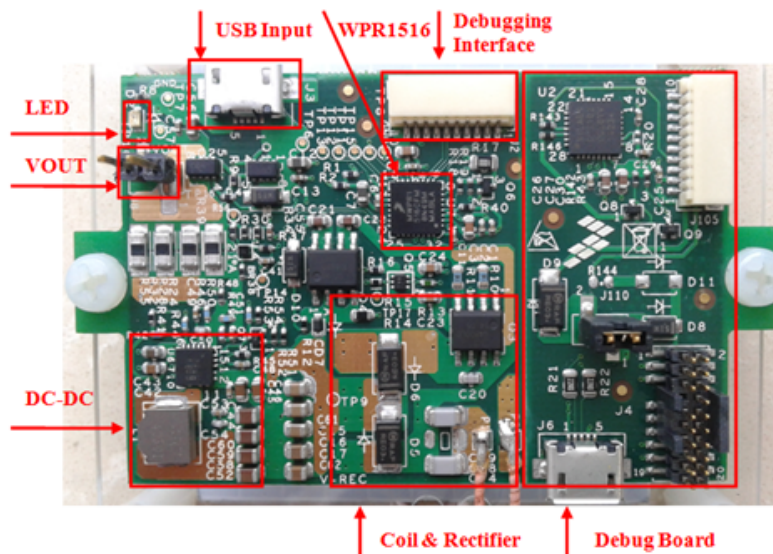

Figure 4. WPR1500-BUCK board modules overview

- Controller

The Freescale WPR15xx MCU is the central controller of the WPR1500 receiver board. The chip is a higher integration receiver controller MCU for wireless power transfer application.

The WPR15xx is a Cortex[®] M0+ core ASSP with Freescale's UHV technology. It includes the FSK and CNC models that allow easy development for bi-directional communication architecture between the transmitter and receiver. The PGA model handles small signal, which eases the solution for foreign object detection. The USB / adapter switcher sets the priority between wired and wireless charging.

The following modules are used in this application:

- CNC controls the communication and provides AC protection
- High voltage input PMC module with three power modes: Run, Wait, Stop
- Programmable gain amplifier (PGA) with differential input and output
- FSK demodulation timer (FSKDT)
- WDOG with independent clock source
- Rectifier

The rectifier uses self-driven sync type. It has the following characteristics:

 - Input voltage : 3.5 V – 20 V AC peak
 - Output voltage: 3.5 V – 20 V DC
- Communication
 - The ASK differential bi-phase signal is modulated by switching the modulation capacitor
 - The FSK signal is demodulated by the CNC and FSKDT modules
- USB switch
 - The CNC module automatically detects the input voltage from wired power plugs, and switches on wired power when the input voltage is in the range of 4.5 V ~ 5.5 V
- DC–DC converter
 - Input voltage : 5 V ~ 21 V DC
 - Output voltage / current: 5 V DC / 3 A.

6 Getting started

6.1 System development environment

The WPR1500 receiver board supports debugging using the IAR and FreeMASTER tools. The set-up of the debug connection is shown in [Figure 5](#). The debugger and the debug board are placed between the PC and the receiver board.

In order to download image onto the WPR1516 chip, user must connect a debugger (J-LINK or P&E-Multilink FX) to the SWD port of a debug board, and connect the debug board to the receiver board using a 10-pin cable. The micro interface on the debug board must be connected to the USB in order to get power.

To monitor the working status of the WPR1500 receiver board, user must short jumper J110 on the debug board, and connect the micro interface on the debug board to the PC through a micro USB cable.

Figure 5 shows the connection diagram, and Figure 6 shows a real setup.

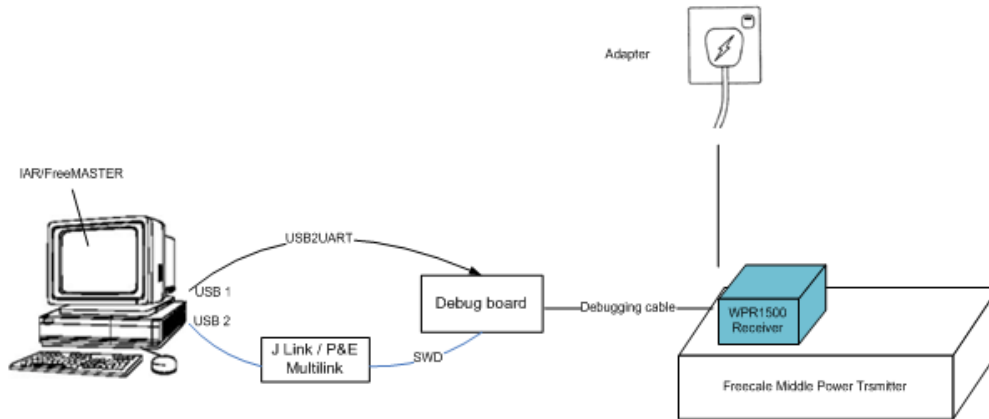

Figure 5. Debug connections

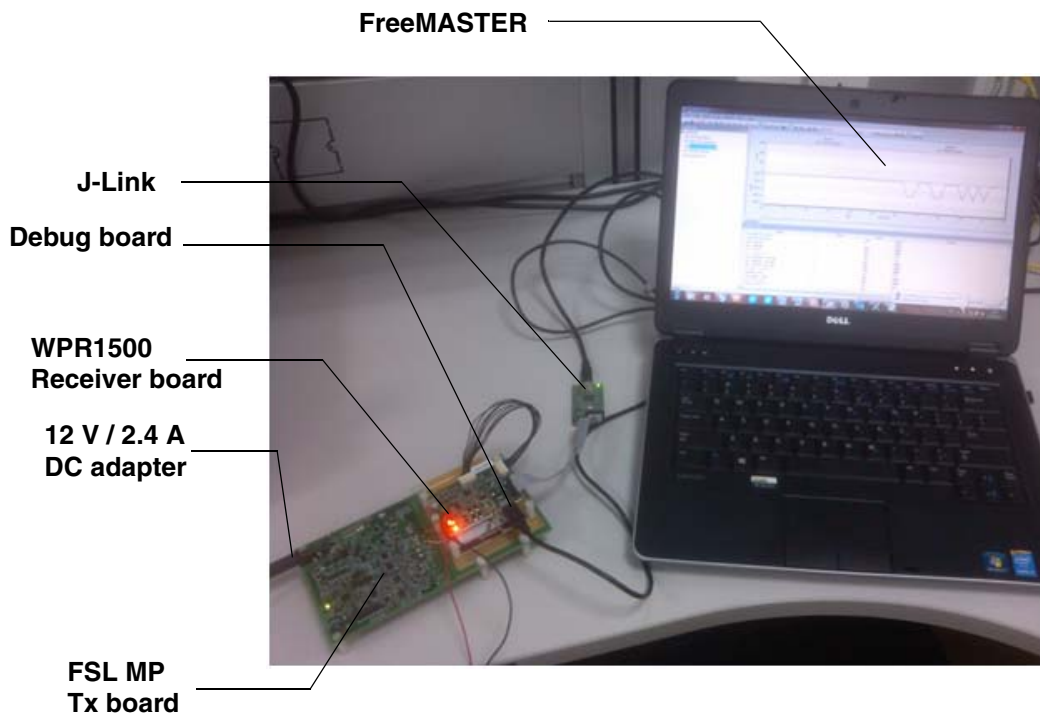

Figure 6. Development environment

For details on the J-Link debugger, visit freescale.com and search for “J-Link”.

6.2 Downloading and debugging firmware

6.2.1 Connecting the J-Link debugger

Connect the J-Link debugger to the SWD port of the debug board, and connect the debug board to the receiver board using a 10-pin cable.

NOTE

The micro interface on the debug board must be connected to the USB in order to receive power. Please confirm the jumper J110 is connected before the download.

The J-Link connection is shown in [Figure 7](#).

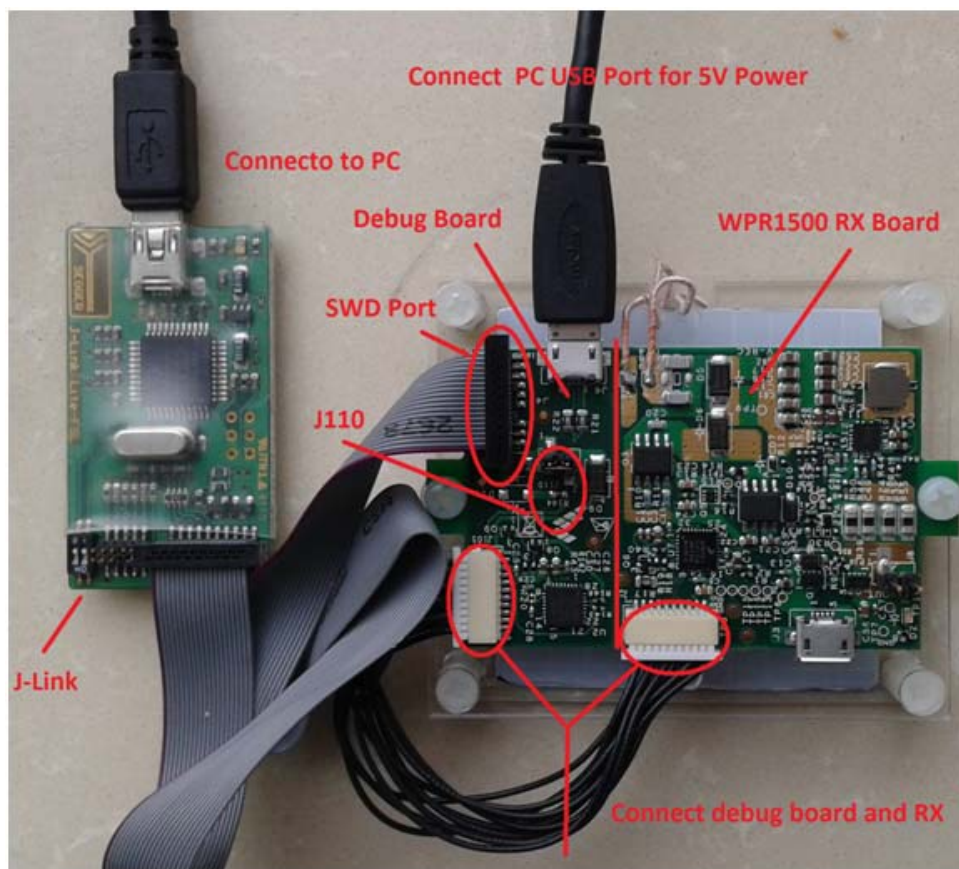

Figure 7. J-Link connection

When the J-Link is plugged into the PC, it can be found in Windows Device Manager, as shown in [Figure 8](#) and [Figure 9](#).

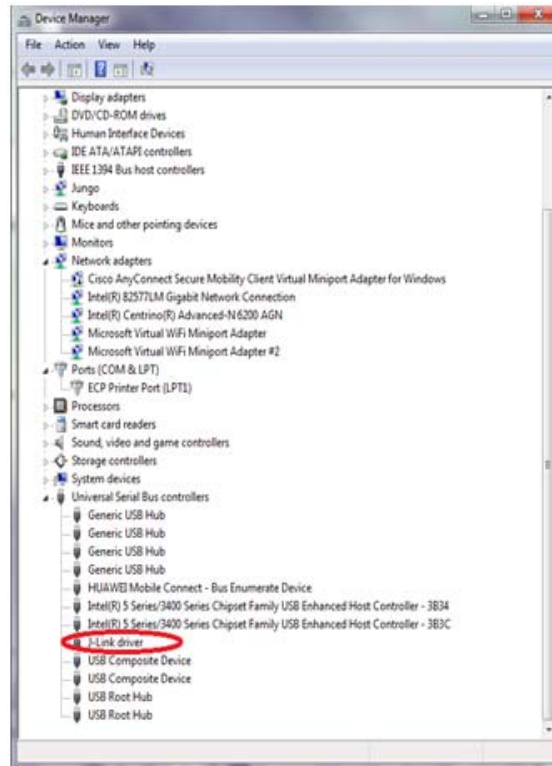

Figure 8. J-Link debugger plugged in



Figure 9. P&E Multilink debugger plugged in

6.2.2 Downloading an existing WPR1500 project using IAR

In order to download an existing WPR1500 project using IAR, please perform the following steps:

1. Set-up the IAR embedded workbench.

The IAR embedded workbench tool is required. Since the receiver driver library is already included in the lib folder of the wireless charger application project, you can open the application project and build the applications directly whenever the wpr_lib.a is ready.

The demo applications workspace files are located in:

<project_name>/build/iar/<board_name>/<project_name>.eww

2. Build a project.

Click on the “Rebuild All” button:

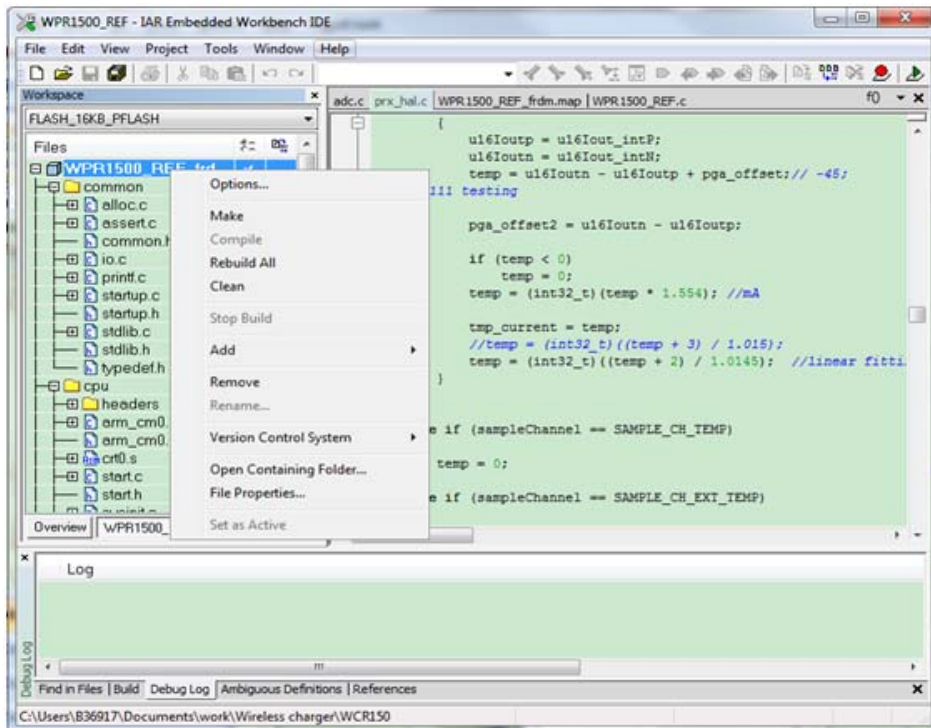

Figure 10. Building a project

When the build is complete, the IAR displays this information in the build window:

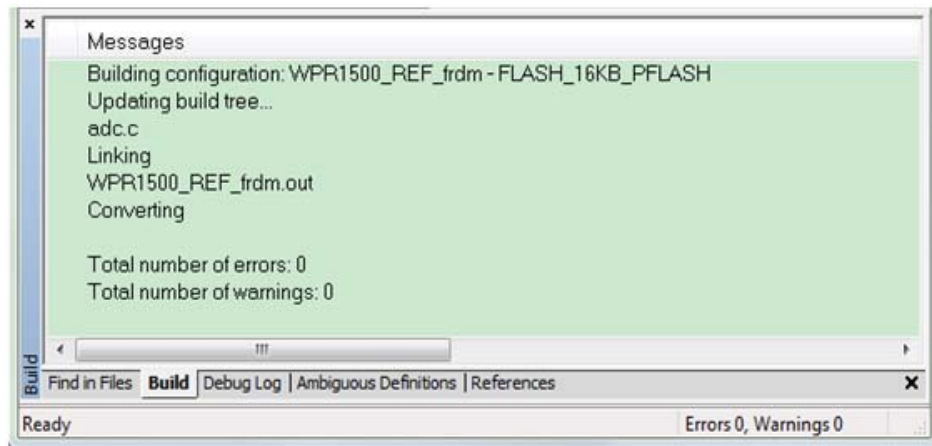

Figure 11. Successful build of a project

3. Ensure that the debugger is configured properly in the project options.
The flash loader must be selected in order to support downloading of the binary to internal flash:

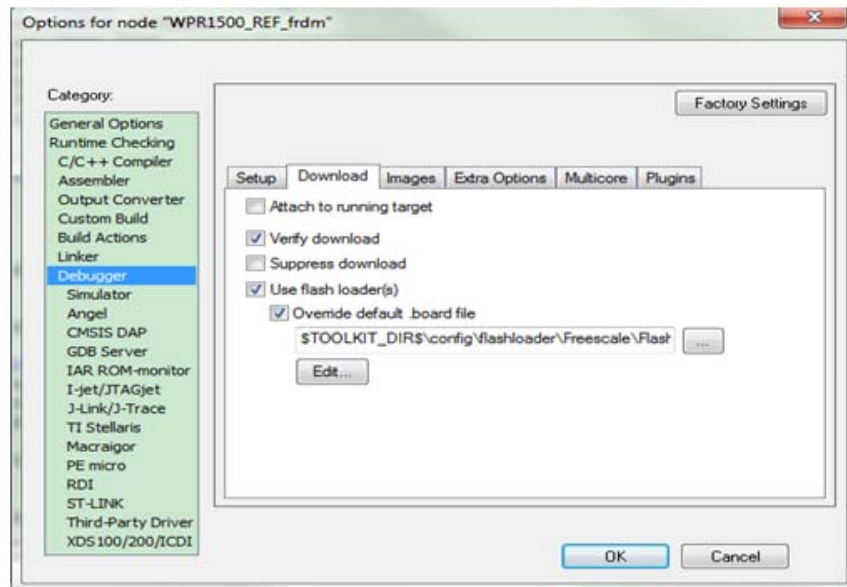

Figure 12. Flash loader configuration

When using J-Link as a debugger, please select J-link/J-Trace:

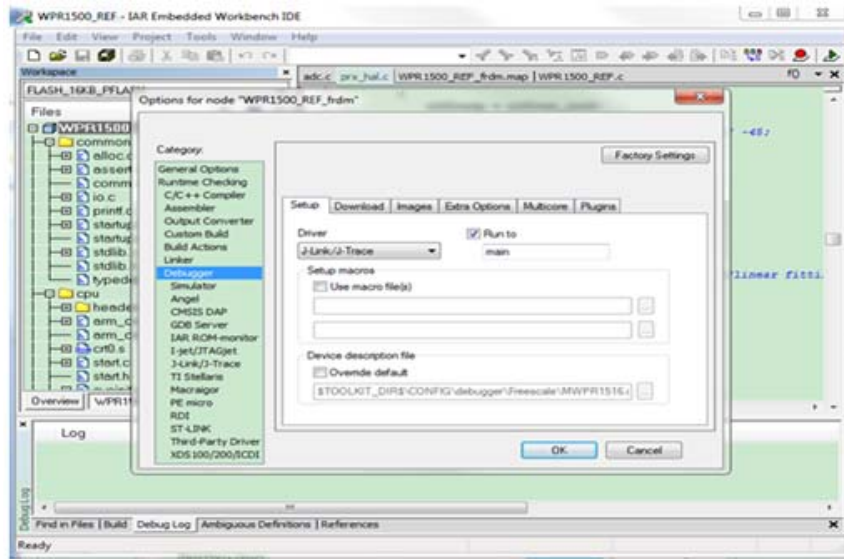

Figure 13. J-Link debugger configuration for driver

When using P&E Multilink as a debugger, please select PE micro:

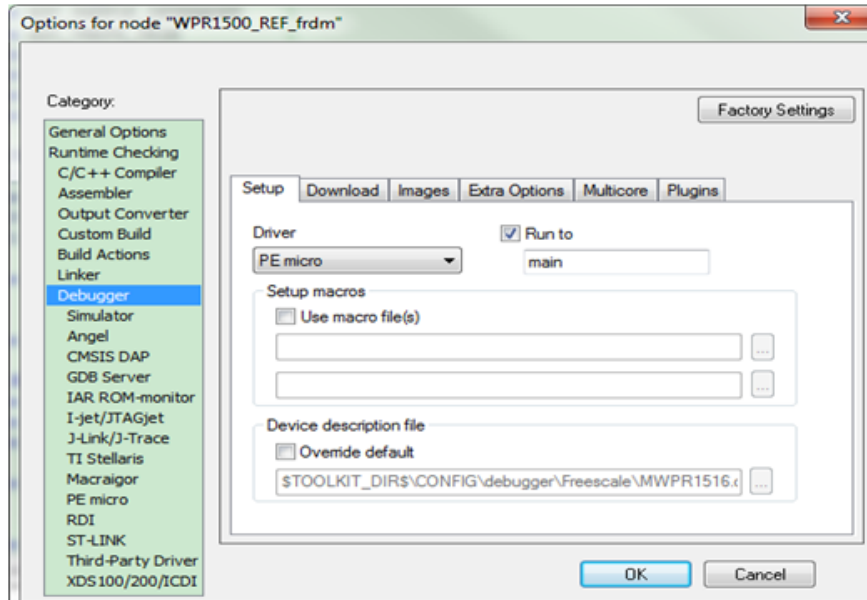

Figure 14. P&E Multilink debugger configuration for driver

The P&E Multilink is configured in the PE micro settings as shown in [Figure 15](#).

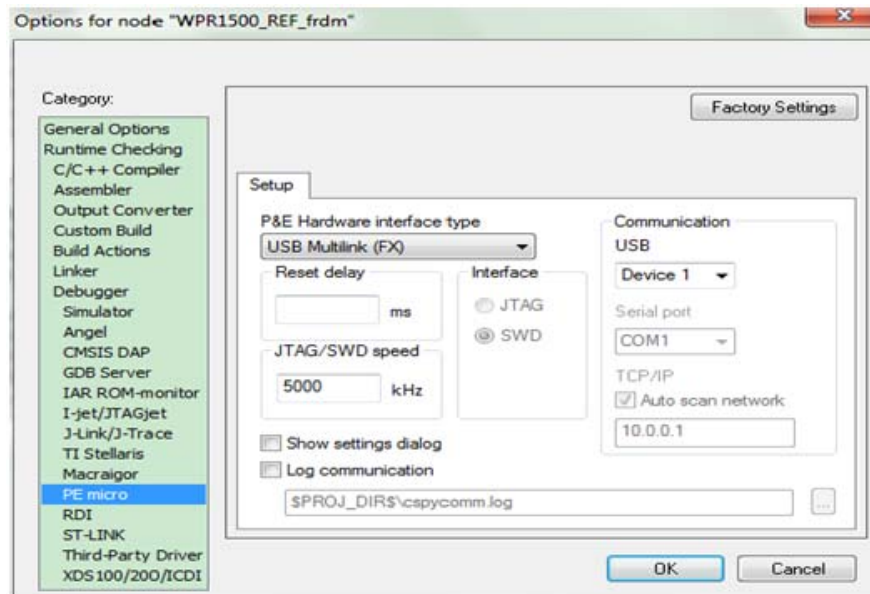

Figure 15. Debugger configuration for PE micro

- Download the project.

After the application is built successfully, click on the “Download and Debug” button to download the application to the target device.



Figure 16. Download and Debug button

The programming of a project is shown in [Figure 17](#).

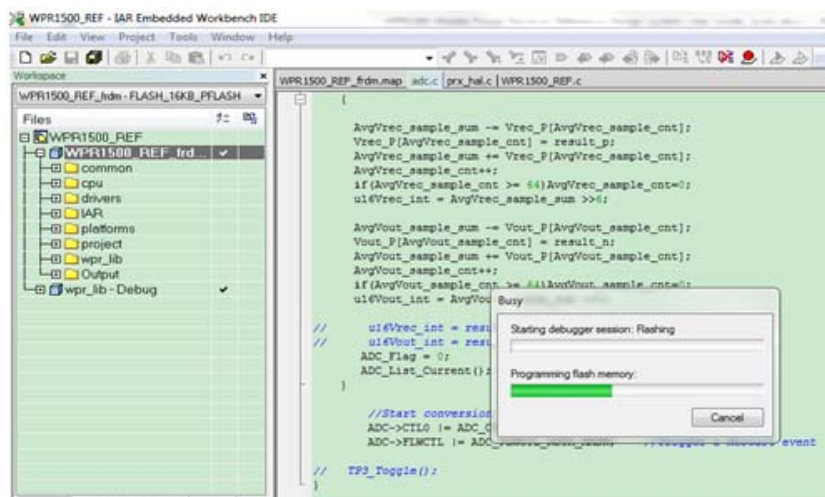

Figure 17. Programming a project

Getting started

5. After the application is downloaded onto the target device, the debugger stops executing at the start of the main() function:

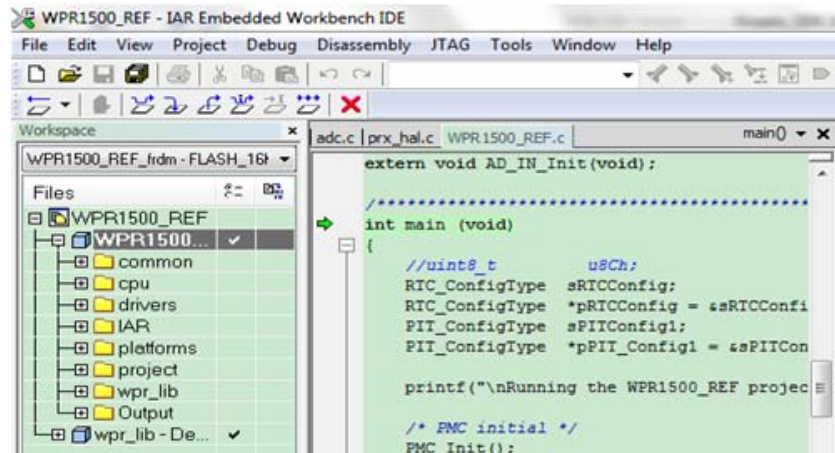

Figure 18. Stopping at main() when debugging

6.3 Debugging the WPR1500 receiver using FreeMASTER

6.3.1 Connecting the debug cable

The FreeMASTER debug connection is shown in Figure 19. User must confirm the jumper J110 is removed before debugging, then put the receiver on the transmitter panel.

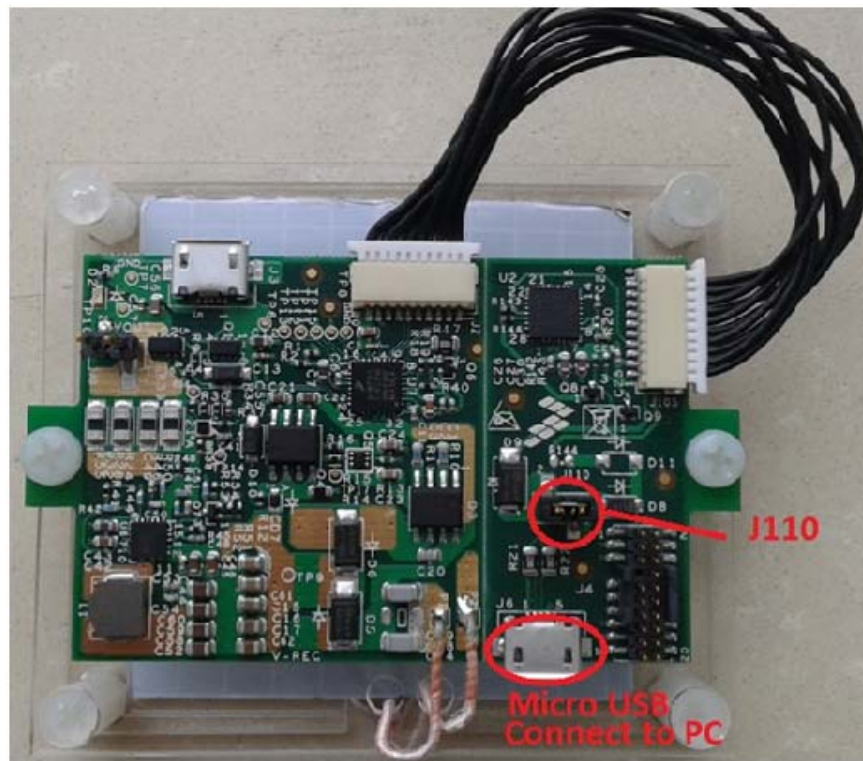

Figure 19. FreeMASTER debug connection

6.3.2 Using FreeMASTER

Freescale provides the FreeMASTER GUI tool for system status monitoring. User must use the WPR1500_REF.pmp file. For information on the FreeMASTER tool, visit freescale.com/Freemaster.

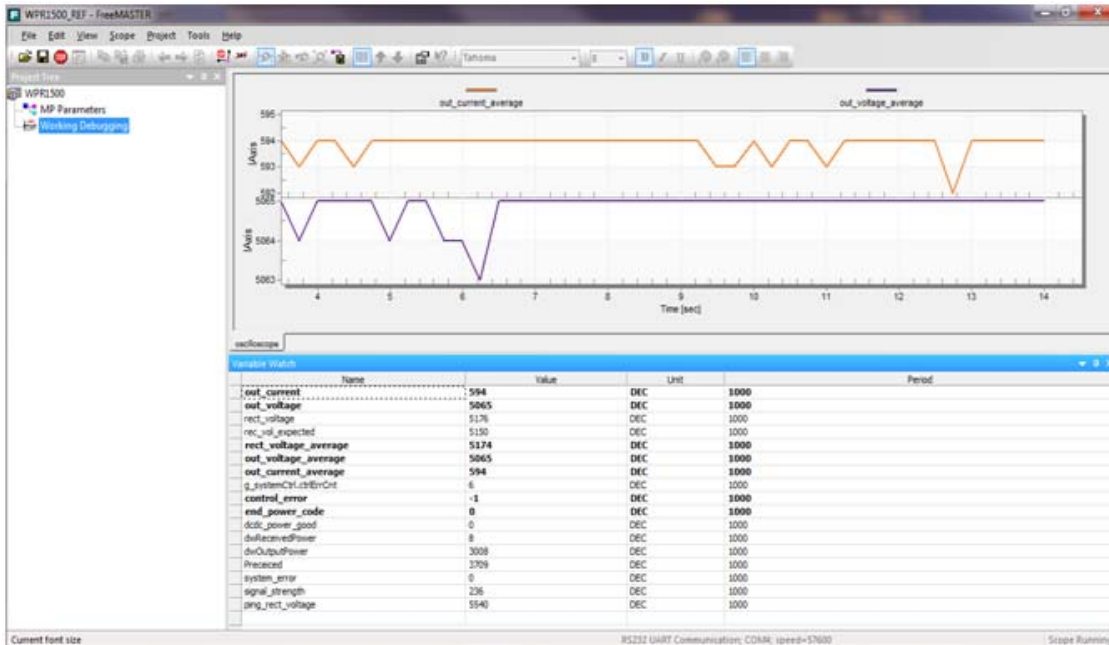

Figure 20. FreeMASTER GUI tool

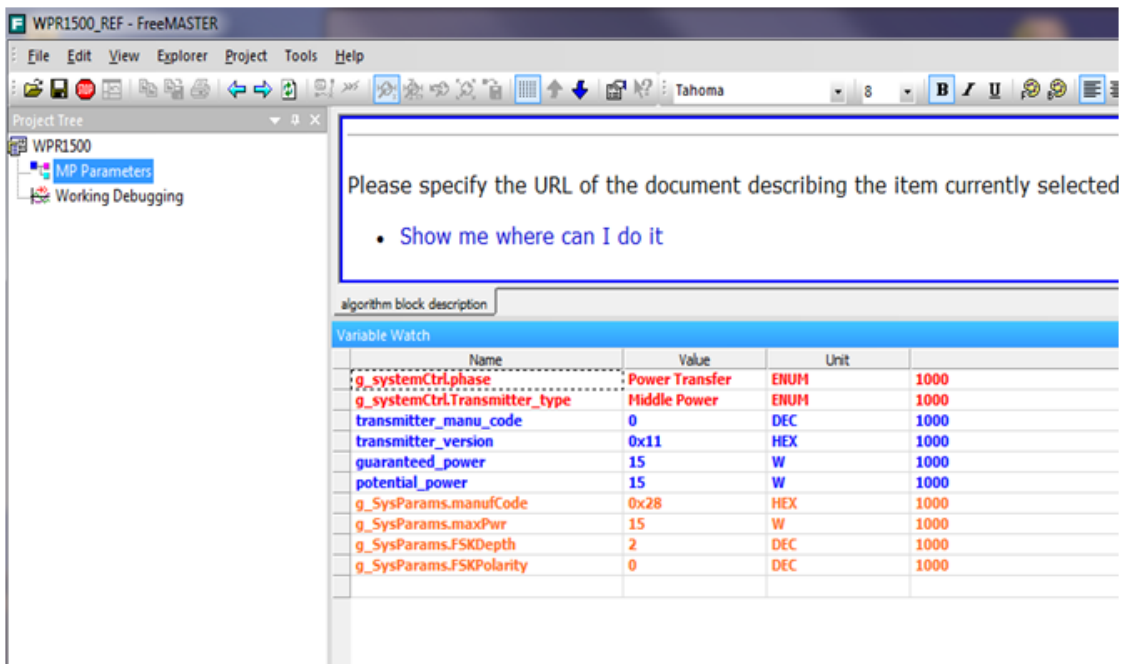

Figure 21. Medium power receiver parameters

6.3.2.1 How to set up FreeMASTER connection to the target board

1. Set symbol file for your project.

Select a symbol file by navigating to FreeMASTER Project → Options → MAP Files, as shown in Figure 22.

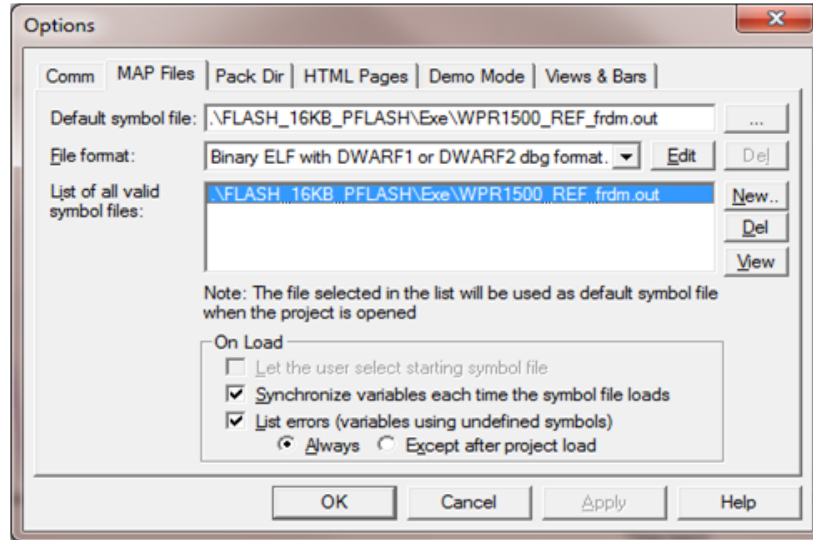

Figure 22. Selecting symbol file

2. Adjust the settings for using FreeMASTER.

Select “Direct RS232” by navigating to FreeMASTER Project → Options → Comm, as shown in Figure 23.

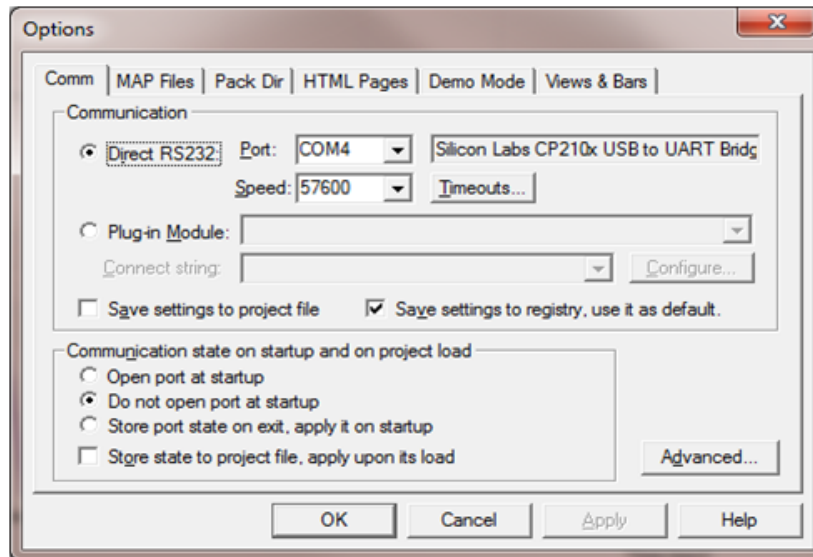

Figure 23. Options dialog box

6.4 Testing

6.4.1 Signals on the board

The main signals on the WPR1500 reference board are shown in [Figure 24](#).

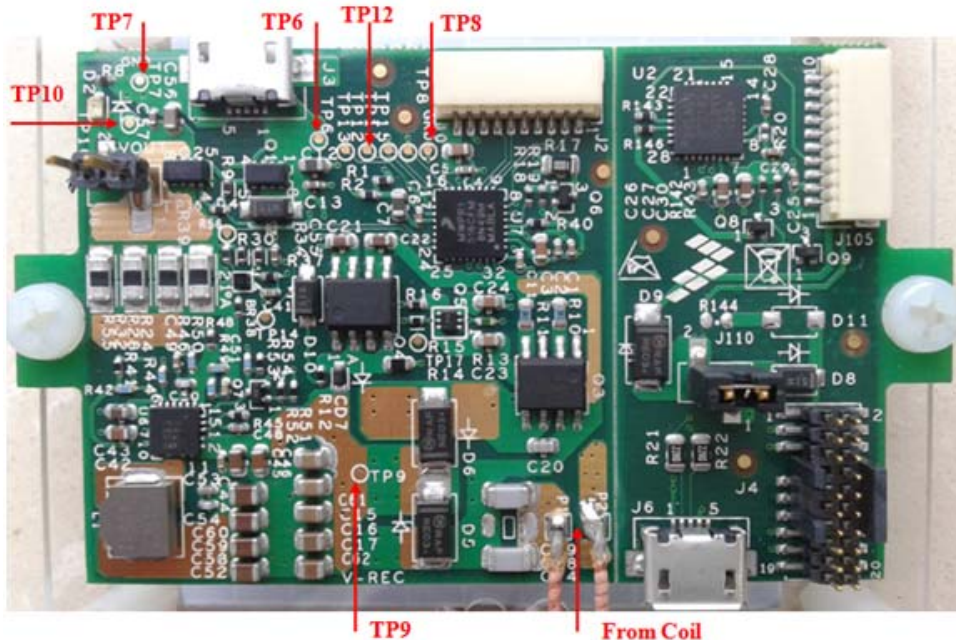

Figure 24. Test points on the WPR1500-BUCK board

Testing points on the WPR1500 BUCK board are as follows:

- TP6: USB input voltage
- TP9: VREC
- TP7 & TP8: GND
- TP12: DC-DC output enable

Several examples to show how to measure and debug the board follow.

1. [Figure 25](#) shows the input voltage and communication signal from ping phase to power transfer setup.
 - Channel 1: rectifier DC output voltage VREC
 - Channel 2: coil AC input voltage V_Coil
 - Channel 3: communication signal CTX
 - Channel 4: coil AC input current I_Coil

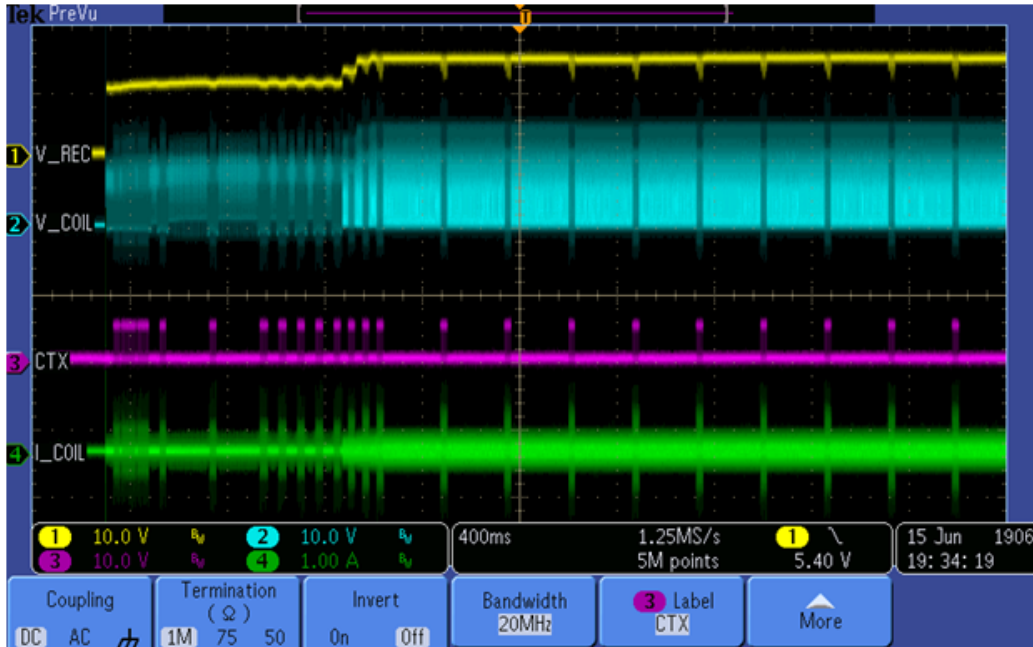

Figure 25. Ping process of the wireless power receiver

- System response measurement for a 3 A load is shown in Figure 26.

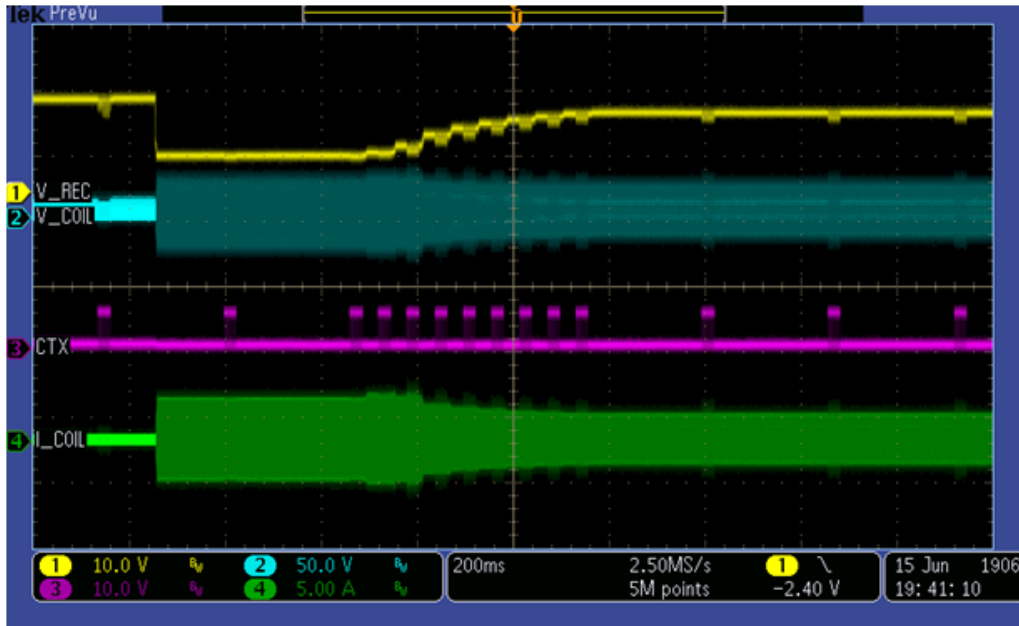

Figure 26. System response for a 3 A load

3. System response measurement for adding the load gradually from 0 A is shown in [Figure 27](#).

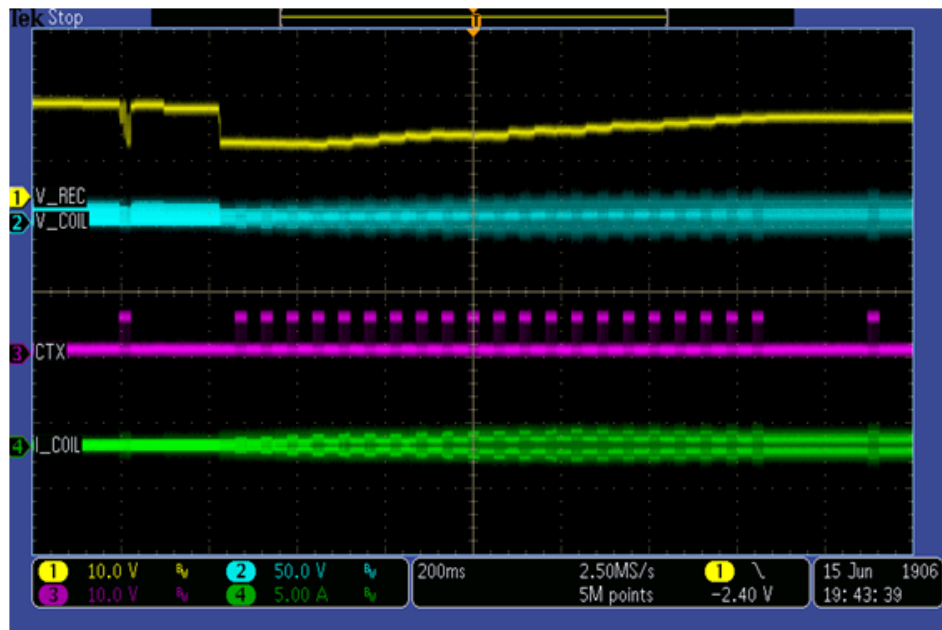

Figure 27. System response for adding loading gradually

4. System response measurement for reducing the load from 3 A to 0 A is shown in [Figure 28](#).

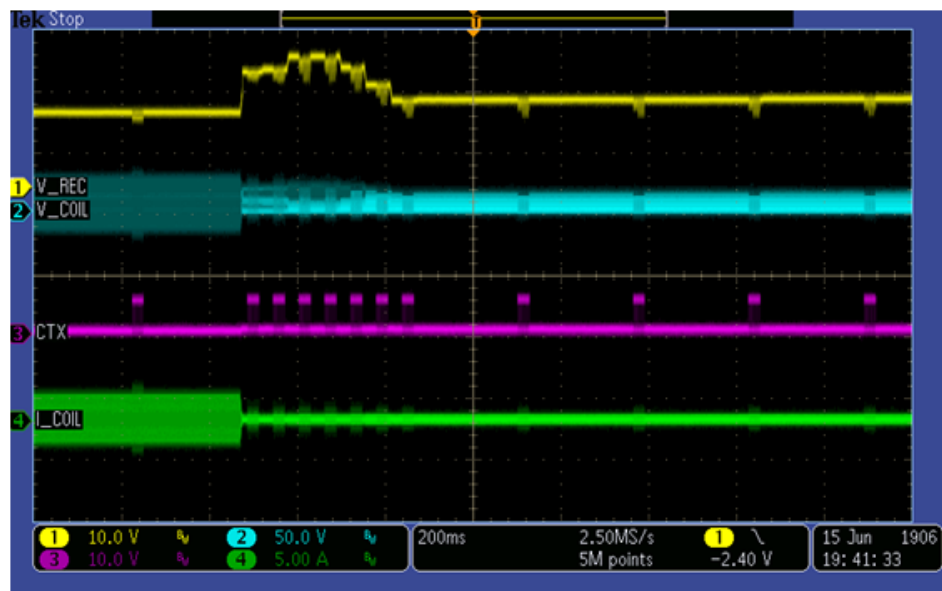

Figure 28. System response for reducing the load from 3 A to 0 A

7 References

- Freescale wireless charging solution page:
freescale.com/wirelesscharging
- Freescale FreeMASTER tool page:
freescale.com/Freemaster
- WPC page:
www.wirelesspowerconsortium.com

8 Revision history

Table 2. Revision history

Rev. number	Date	Substantive change(s)
0	12/2014	Initial release

How to Reach Us:

Home Page:
freescale.com

Web Support:
freescale.com/support

Information in this document is provided solely to enable system and software implementers to use Freescale products. There are no express or implied copyright licenses granted hereunder to design or fabricate any integrated circuits based on the information in this document.

Freescale reserves the right to make changes without further notice to any products herein. Freescale makes no warranty, representation, or guarantee regarding the suitability of its products for any particular purpose, nor does Freescale assume any liability arising out of the application or use of any product or circuit, and specifically disclaims any and all liability, including without limitation consequential or incidental damages. "Typical" parameters that may be provided in Freescale data sheets and/or specifications can and do vary in different applications, and actual performance may vary over time. All operating parameters, including "typicals," must be validated for each customer application by customer's technical experts. Freescale does not convey any license under its patent rights nor the rights of others. Freescale sells products pursuant to standard terms and conditions of sale, which can be found at the following address: freescale.com/SalesTermsandConditions.

Freescale and the Freescale logo are trademarks of Freescale Semiconductor, Inc., Reg. U.S. Pat. & Tm. Off. Cortex is the registered trademark of ARM limited. All other product or service names are the property of their respective owners.

© 2014 Freescale Semiconductor, Inc.