

Description:

Powerex Mega Power Dual (MPD) Modules are designed for use in switching applications. Each module consists of two IGBT Transistors having a reverse-connected super-fast recovery free-wheel diode. All components and interconnects are isolated from the heat sinking baseplate, offering simplified system assembly and thermal management.

Features:

- Low Drive Power
- Low $V_{CE(sat)}$
- Discrete Super-Fast Recovery Free-Wheel Diode
- Isolated Baseplate for Easy Heatsinking
- RoHS Compliant

Applications:

- High Power DC Power Supply
- Large DC Motor Drives
- Utility Interface Inverters

Ordering Information:

Example: Select the complete module number you desire from the table - i.e. CM900DUC-24S is a 1200V (V_{CES}), 900 Ampere Dual IGBTMOD Power Module.

Type	Current Rating Amperes	V_{CES} Volts (x 50)
CM	900	24

Outline Drawing and Circuit Diagram

Dimensions	Inches	Millimeters
A	5.91	150.0
B	5.10	129.5
C	1.67±0.01	42.5±0.25
D	5.41±0.01	137.5±0.25
E	6.54	166.0
F	2.91±0.01	74.0±0.25
G	1.65	42.0
H	0.55	14.0
J	1.50±0.01	38.0±0.25
K	0.16	4.0
L	1.36 +0.04/-0.02	34.6 +1.0/-0.5

Dimensions	Inches	Millimeters
M	0.075±0.008	1.9±0.2
N	0.47	12.0
P	0.26	6.5
R	M6 Metric	M6
S	0.08	2.0
T	0.99	25.1
U	0.62	15.7
V	0.71	18.0
W	0.75	19.0
X	0.43	11.0
Y	0.83	21.0
Z	0.41	10.5
AA	0.22	5.5

Housing Type (J.S.T. MFG. CO. LTD)

BB = VHR-2N
 CC = VHR-5N

CM900DUC-24S
Mega Power Dual IGBT
 900 Amperes/1200 Volts

Absolute Maximum Ratings, $T_j = 25^\circ\text{C}$ unless otherwise specified

Characteristics	Symbol	Rating	Units
Collector-Emitter Voltage ($V_{GE} = 0V$)	V_{CES}	1200	Volts
Gate-Emitter Voltage ($V_{CE} = 0V$)	V_{GES}	± 20	Volts
Collector Current (DC, $T_C = 125^\circ\text{C}$) ^{*2,*4}	I_C	900	Amperes
Collector Current (Pulse, Repetitive) ^{*3}	I_{CRM}	1800	Amperes
Total Power Dissipation ($T_C = 25^\circ\text{C}$) ^{*2,*4}	P_{tot}	6520	Watts
Emitter Current ^{*2}	I_E^{*1}	900	Amperes
Emitter Current (Pulse, Repetitive) ^{*3}	I_{ERM}^{*1}	1800	Amperes
Isolation Voltage (Terminals to Baseplate, RMS, $f = 60\text{Hz}$, AC 1 minute)	V_{isol}	4000	Volts
Maximum Junction Temperature	$T_{j(max)}$	175	$^\circ\text{C}$
Maximum Case Temperature	$T_C (max)$	125	$^\circ\text{C}$
Operating Junction Temperature	$T_{j(op)}$	-40 to +150	$^\circ\text{C}$
Storage Temperature	T_{stg}	-40 to +125	$^\circ\text{C}$

*1 Represent ratings and characteristics of the anti-parallel, emitter-to-collector clamp diode.

*2 Junction temperature (T_j) should not increase beyond maximum junction temperature ($T_{j(max)}$) rating.

*3 Pulse width and repetition rate should be such that device junction temperature (T_j) does not exceed $T_{j(max)}$ rating.

*4 Case temperature (T_C) and heatsink temperature (T_s) is measured on the surface (mounting side) of the baseplate and the heatsink side just under the chips. Refer to the figure to the right for chip location.

The heatsink thermal resistance should be measured just under the chips.

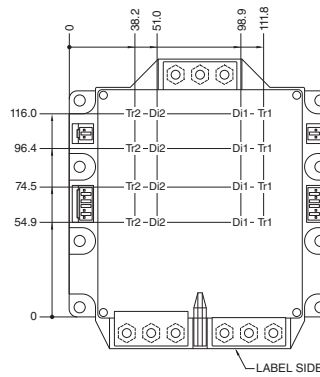

Tr1, Tr2: IGBT, D1, D2: FWDI
 Each mark points to the center position of each chip.

CM900DUC-24S
Mega Power Dual IGBT
 900 Amperes/1200 Volts

Electrical Characteristics, $T_j = 25^\circ\text{C}$ unless otherwise specified

Characteristics	Symbol	Test Conditions	Min.	Typ.	Max.	Units
Collector-Emitter Cutoff Current	I_{CES}	$V_{CE} = V_{CES}, V_{GE} = 0V$	—	—	1	mA
Gate-Emitter Leakage Current	I_{GES}	$V_{GE} = V_{GES}, V_{CE} = 0V$	—	—	3.0	μA
Gate-Emitter Threshold Voltage	$V_{GE(th)}$	$I_C = 90\text{mA}, V_{CE} = 10V$	5.4	6.0	6.6	Volts
Collector-Emitter Saturation Voltage (Terminal)	$V_{CE(sat)}$	$I_C = 900A, V_{GE} = 15V, T_j = 25^\circ\text{C}^{*6}$	—	1.55	1.90	Volts
		$I_C = 900A, V_{GE} = 15V, T_j = 125^\circ\text{C}^{*6}$	—	1.75	—	Volts
		$I_C = 900A, V_{GE} = 15V, T_j = 150^\circ\text{C}^{*6}$	—	1.80	—	Volts
Collector-Emitter Saturation Voltage (Chip)	$V_{CE(sat)}$	$I_C = 900A, V_{GE} = 15V, T_j = 25^\circ\text{C}^{*6}$	—	1.55	1.90	Volts
		$I_C = 900A, V_{GE} = 15V, T_j = 125^\circ\text{C}^{*6}$	—	1.75	—	Volts
		$I_C = 900A, V_{GE} = 15V, T_j = 150^\circ\text{C}^{*6}$	—	1.80	—	Volts
Input Capacitance	C_{ies}		—	—	90	nF
Output Capacitance	C_{oes}	$V_{CE} = 10V, V_{GE} = 0V$	—	—	18	nF
Reverse Transfer Capacitance	C_{res}		—	—	1.5	nF
Gate Charge	Q_G	$V_{CC} = 600V, I_C = 900A, V_{GE} = 15V$	—	2300	—	nC
Turn-on Delay Time	$t_{d(on)}$		—	—	900	ns
Rise Time	t_r	$V_{CC} = 600V, I_C = 900A, V_{GE} = \pm 15V,$	—	—	250	ns
Turn-off Delay Time	$t_{d(off)}$	$R_G = 0\Omega, \text{Inductive Load}$	—	—	950	ns
Fall Time	t_f		—	—	350	ns
Emitter-Collector Voltage (Terminal)	V_{EC}^{*1}	$I_E = 900A, V_{GE} = 0V, T_j = 25^\circ\text{C}^{*6}$	—	1.65	2.10	Volts
		$I_E = 900A, V_{GE} = 0V, T_j = 125^\circ\text{C}^{*6}$	—	1.65	—	Volts
		$I_E = 900A, V_{GE} = 0V, T_j = 150^\circ\text{C}^{*6}$	—	1.65	—	Volts
Emitter-Collector Voltage (Chip)	V_{EC}^{*1}	$I_E = 900A, V_{GE} = 0V, T_j = 25^\circ\text{C}^{*6}$	—	1.65	2.10	Volts
		$I_E = 900A, V_{GE} = 0V, T_j = 125^\circ\text{C}^{*6}$	—	1.65	—	Volts
		$I_E = 900A, V_{GE} = 0V, T_j = 150^\circ\text{C}^{*6}$	—	1.65	—	Volts
Reverse Recovery Time	t_{rr}^{*1}	$V_{CC} = 600V, I_E = 900A, V_{GE} = \pm 15V$	—	—	450	ns
Reverse Recovery Charge	Q_{rr}^{*1}	$R_G = 0\Omega, \text{Inductive Load}$	—	50	—	μC
Turn-on Switching Energy per Pulse	E_{on}	$V_{CC} = 600V, I_C = I_E = 900A,$	—	65.3	—	mJ
Turn-off Switching Energy per Pulse	E_{off}	$V_{GE} = \pm 15V, R_G = 0\Omega, T_j = 150^\circ\text{C},$	—	183	—	mJ
Reverse Recovery Energy per Pulse	E_{rr}^{*1}	Inductive Load	—	73.3	—	mJ
Internal Lead Resistance	$R_{CC} + EE^{*4}$	Main Terminals-Chip, Per Switch, $T_C = 25^\circ\text{C}^{*4}$	—	0.286	—	m Ω
Internal Gate Resistance	r_g	Per Switch	—	2.2	—	Ω

*1 Represent ratings and characteristics of the anti-parallel, emitter-to-collector clamp diode.

*4 Case temperature (T_C) and heatsink temperature (T_S) is measured on the surface (mounting side) of the baseplate and the heatsink side just under the chips. Refer to the figure to the right for chip location. The heatsink thermal resistance should be measured just under the chips.

*6 Pulse width and repetition rate should be such as to cause negligible temperature rise.

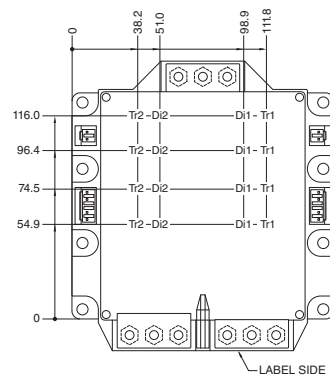

Tr1, Tr2: IGBT, Di1, Di2: FWDI
 Each mark points to the center position of each chip.

CM900DUC-24S
Mega Power Dual IGBT
 900 Amperes/1200 Volts

Electrical Characteristics, $T_j = 25^\circ\text{C}$ unless otherwise specified (continued)

Thermal Resistance Characteristics

Thermal Resistance, Junction to Case ^{*4}	$R_{th(j-c)Q}$	Per Inverter IGBT	—	—	23	K/kW
Thermal Resistance, Junction to Case ^{*4}	$R_{th(j-c)D}$	Per Inverter Diode	—	—	39	K/kW
Contact Thermal Resistance, Case to Heatsink	$R_{th(c-f)}$ (Per 1 Module) ^{*7}	Thermal Grease Applied	—	6	—	K/kW

Mechanical Characteristics

Mounting Torque	M_t	Main Terminals, M6 Screw	22	27	31	in-lb
	M_s	Mounting to Heatsink, M6 Screw	22	27	31	in-lb
Creepage Distance	d_s	Terminal to Terminal	24	—	—	mm
		Terminal to Baseplate	33	—	—	mm
Clearance	d_a	Terminal to Terminal	14	—	—	mm
		Terminal to Baseplate	33	—	—	mm
Weight	m		—	1450	—	Grams
Flatness of Baseplate	e_c	On Centerline X, Y ^{*5}	-50	—	+100	μm

Recommended Operating Conditions, $T_a = 25^\circ\text{C}$

(DC) Supply Voltage	V_{CC}	Applied Across P-N	—	600	850	Volts
Gate-Emitter Drive Voltage	$V_{GE(on)}$	Applied Across G-Es	13.5	15.0	16.5	Volts
External Gate Resistance	R_G	Per Switch	0	—	3.6	Ω

^{*4} Case temperature (T_C) and heatsink temperature (T_S) is measured on the surface (mounting side) of the baseplate and the heatsink side just under the chips. Refer to the figure to the right for chip location.

The heatsink thermal resistance should be measured just under the chips.

^{*5} Baseplate (mounting side) flatness measurement points (X, Y) are shown in the figure below.

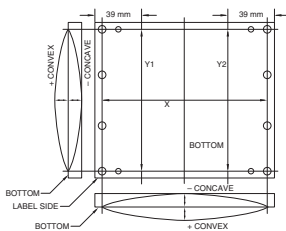

^{*7} Typical value is measured by using thermally conductive grease of $\lambda = 0.9$ [W/(m • K)].

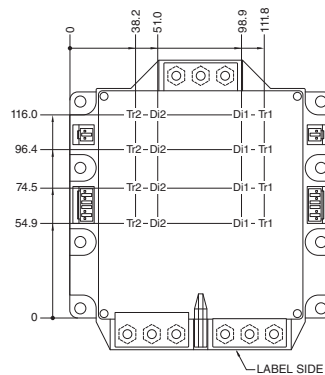

Tr1, Tr2: IGBT, D1, D2: FWDI
 Each mark points to the center position of each chip.



CM900DUC-24S
Mega Power Dual IGBT
 900 Amperes/1200 Volts

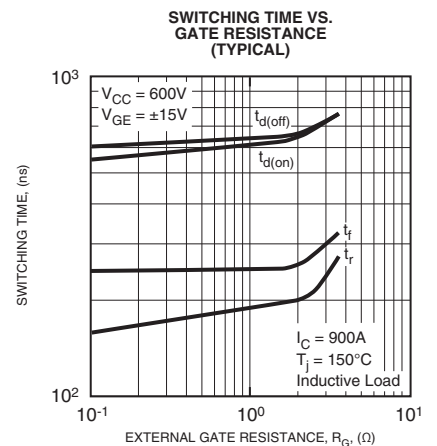
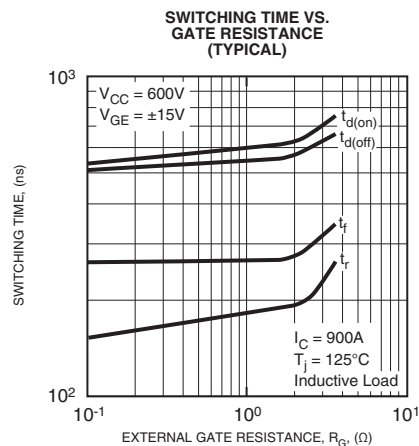
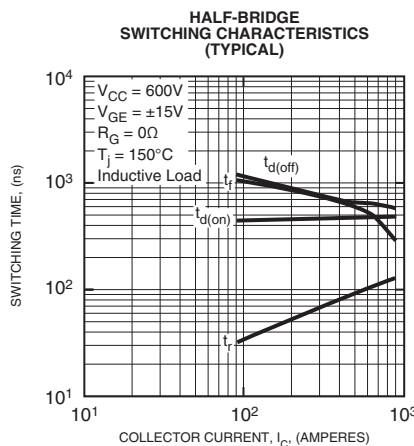
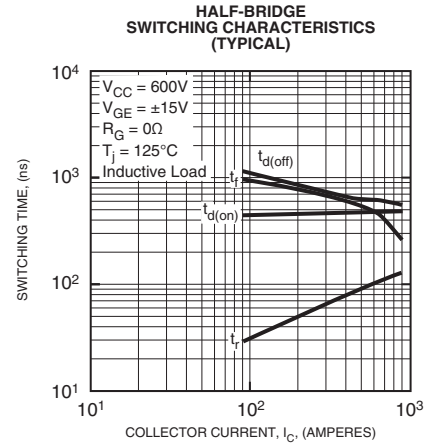
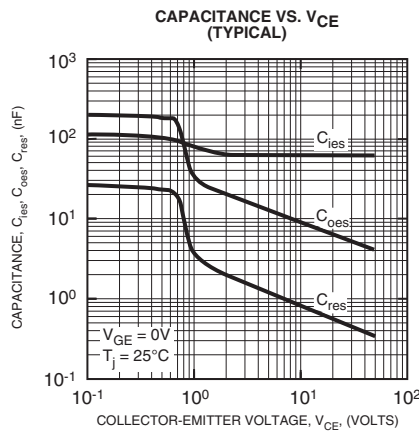
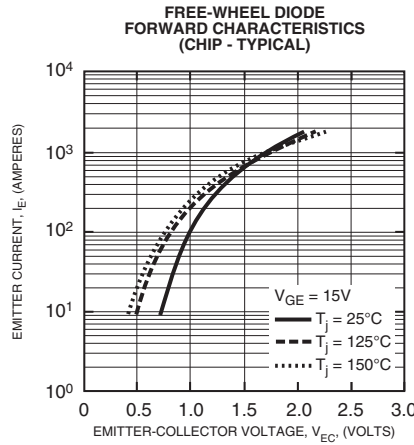
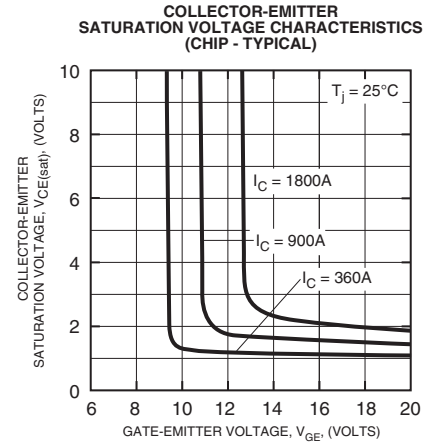
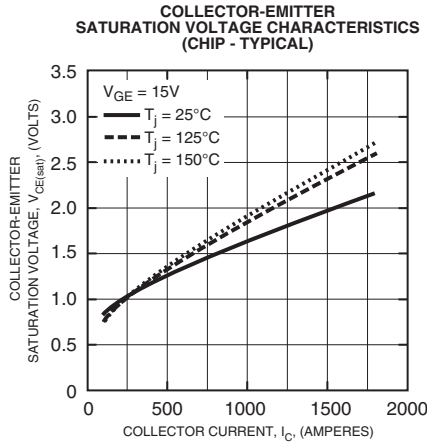
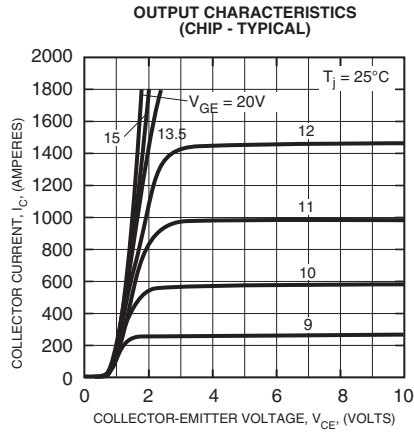

CM900DUC-24S
Mega Power Dual IGBT
 900 Amperes/1200 Volts

REVERSE RECOVERY CHARACTERISTICS (TYPICAL)

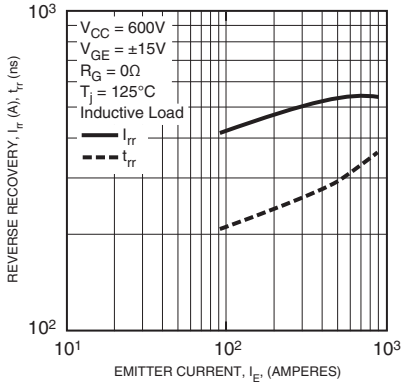

REVERSE RECOVERY CHARACTERISTICS (TYPICAL)

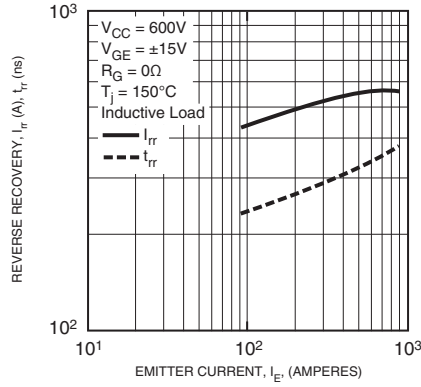

GATE CHARGE VS. V_GE

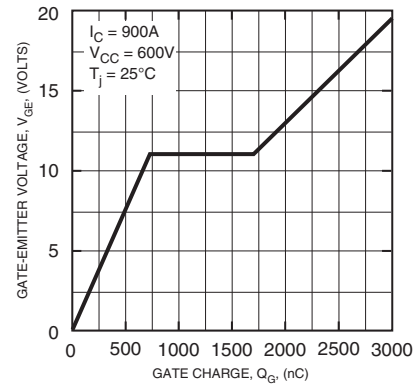

HALF-BRIDGE SWITCHING CHARACTERISTICS (TYPICAL)

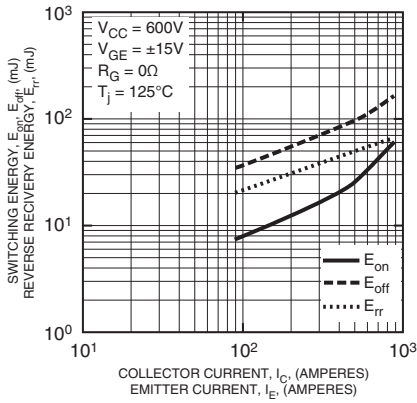

HALF-BRIDGE SWITCHING CHARACTERISTICS (TYPICAL)

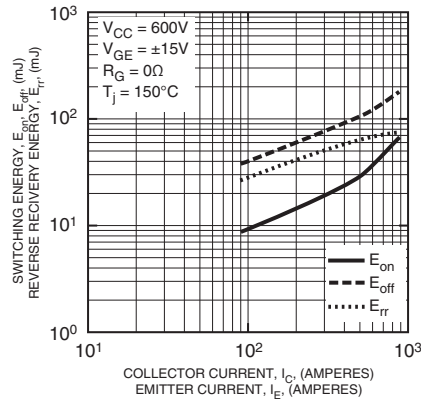

HALF-BRIDGE SWITCHING CHARACTERISTICS (TYPICAL)

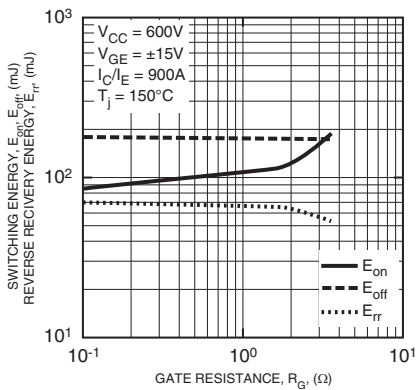
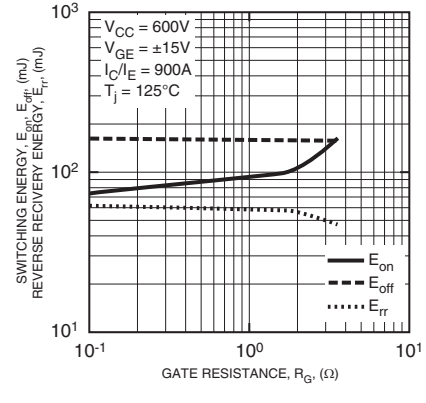

TRANSIENT THERMAL IMPEDANCE CHARACTERISTICS (MAXIMUM)

