

PLEASE CHECK WWW.MOLEX.COM FOR LATEST PART INFORMATION

Part Number: [19005-0005](#)
Status: **Active**
Overview: Standard Quick-Disconnect Terminals
Description: InsulKrimp™ Fully Insulated Coupler, Female, for 14-16 AWG Wire, Box

Documents:

3D Model	Product Specification PS-19902-011 (PDF)
Drawing (PDF)	Product Specification PS-19902-013 (PDF)
Product Specification PS-19902-008 (PDF)	RoHS Certificate of Compliance (PDF)

Agency Certification

CSA	LR18689
UL	E79133

General

Product Family	Quick Disconnects
Series	19005
Crimp Quality Equipment	Yes
Insulated	Fully
MolexKits	Yes
Overview	Standard Quick-Disconnect Terminals
Product Name	InsulKrimp™
Type	Quick Disconnect
UPC	800753030480

Physical

Barrel Type	Closed
Color - Resin	Blue
Flammability	94V-2
Gender	Female
Glow-Wire Compliant	Yes
Insulation	Nylon (PA)
Lock to Mating Part	None
Material - Metal	Brass
Material - Plating Mating	Tin
Material - Plating Termination	Tin
Material - Resin	Nylon
Net Weight	1.088/g
Orientation	Straight
Packaging Type	Bag
Polarized to Mating Part	No
Tab Thickness	0.81mm
Tab Width	6.35mm
Temperature Range - Operating	-65°C to +105°C
Wire Insulation Diameter	4.19mm max.
Wire Size AWG	14, 16
Wire Size mm²	1.30 - 2.00

Electrical

Voltage - Maximum	600V
-------------------	------

Material Info

Old Part Number	BB-2263
-----------------	---------

Reference - Drawing Numbers

Product Specification	PS-19902-008, PS-19902-011, PS-19902-013
Sales Drawing	SD-19005-001

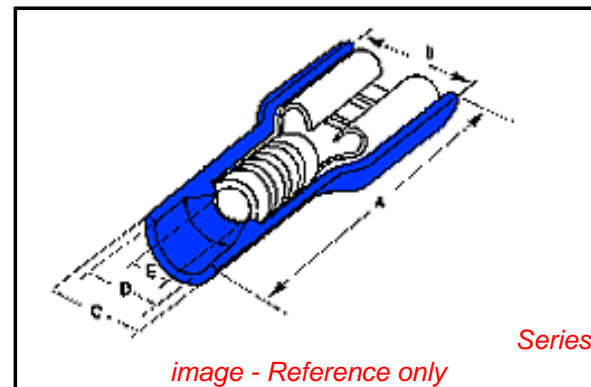

EU RoHS

ELV and RoHS Compliant
REACH SVHC Contains SVHC: No
Low-Halogen Status Low-Halogen

China RoHS



Need more information on product environmental compliance?

Email productcompliance@molex.com
 For a multiple part number RoHS Certificate of Compliance, [click here](#)

Please visit the [Contact Us](#) section for any non-product compliance questions.

Search Parts in this Series

19005Series

Use With

19004-0005 , 19004-0008

Application Tooling | FAQ

Tooling specifications and manuals are found by selecting the products below. Crimp Height Specifications are then contained in the Application Tooling Specification document.

Global

Description	Product #
Hand Crimp Tool	0640014700
Crimp Head for the AT-200™ Pneumatic Hand Tool	0640054700

This document was generated on 02/24/2015

PLEASE CHECK WWW.MOLEX.COM FOR LATEST PART INFORMATION