

LSP10 Module Series



Agency Approvals

Agency	Standard	Agency File Number
	UL1449 3rd Edition	E320116

Applications

- Outdoor and Commercial LED Lighting
- Roadway lighting
- Traffic lighting
- Digital signage
- Wash wall lighting
- Parking garage/lot lighting
- Flood lighting
- Tunnel lighting
- Street lighting

Additional Information



Datasheet



Resources



Samples

Description

The Littelfuse LSP10 thermally protected Surge Protective Device is a self-protected device which is specially designed to be used in outdoor and commercial LED lighting fixtures for transient overvoltage protection. It is constructed with Littelfuse thermally protected varistor technology. Its built-in thermal disconnect function provides additional protection to prevent catastrophic failure and fire hazard even under the extreme circumstances of varistor end-of-life or sustaining over voltage conditions. LSP10 series connected option allows clear indication of thermal fault protection by disconnecting power to luminaire thereby signally SPD module replacement. The LSP10 SPD facilitates customer's product compliance to IEEE C62.41.2 Location Category C High and US Dept of Energy MSSLC Model Spec.

Features

- Maximum Discharge Current, 20kA, 8/20 μ s
- Meets ANSI C136.2 Extreme Level 20kV/10kA and IEEE C62.41.2 Location Category C High Exposure
- Parallel connected and Series connected SPD options
- Thermally protected Varistor technology
- IP66 Water-proof and Dust-proof
- Series connected – Varistor thermal protection indication by removal of power to luminaire
- Indication wire lead options for Parallel connected modules
- IEC61643-11 Class II/ EN61643-11 Class II Compliance
- Compact form factor (48x48x30mm) with mounting tabs
- 240Vac and 277Vac are CE compliance and available for Class I and Class II installation based on IEC protection classes. Please see details in Part Numbering System

Notes:

1. These parts are in compliance with IEC61643-11 Class II (Low Voltage System) and EN61643-11 Type 2 (Low Voltage System).
2. Tested for temporary overvoltage from low-voltage system faults per IEC 61643-11

Absolute Maximum Ratings

• For ratings of individual members of a series, see Device Ratings and Specifications chart

	LSP10 Series	Units
Continous:		
Steady State Applied Voltage:		
AC Voltage Range ($V_{M(AC)(RMS)}$)	150 to 510	V
Transient:		
Maximum Discharge Current 8/20 μ s Waveform (I_{max})	20,000	A
Nominal Discharge Current 8/20 μ s Waveform (I_n)	10,000	A
Operating Ambient Temperature Range (T_A)	-45 to +85	°C
Storage Temperature Range (T_{STG})	-45 to +110	°C
Isolation Voltage Capability (When the thermal disconnect opens)	600	V
Insulation Resistance	>1,000	M Ω

CAUTION: Stresses above those listed in "Absolute Maximum Ratings" may cause permanent damage to the device. This is a stress only rating and operation of the device at these or any other conditions above those indicated in the operational sections of this specification is not implied.

LSP10 Series Device Ratings & Specifications

Part Number	Operating Voltage (VAC)	MCOV/Uc (VAC)	Maximum Discharge Current (Imax)(A) ³	Nominal Discharge Current (In)(A) ²	MLV (V) ⁴	Up (V) ⁵
LSP10120P	120	150	20,000	10,000	L-N:740 L-G:740 N-G:670	900
LSP10240P	240	275	20,000	10,000	L-N:1130 L-G:1130 N-G:1060	1200
LSP10277P	277	320	20,000	10,000	L-N:1330 L-G:1330 N-G:1260	1400
LSP10347P	347	420	20,000	10,000	L-N:1750 L-G:1750 N-G:1680	1900
LSP10480P	480	510	20,000	10,000	L-N:2020 L-G:2020 N-G:1960	2100
LSP10240LLP	L-L:240	L-L:275	20,000	10,000	L-L:1130	L-L:1200
	L-N/G:120	L-N/G:150			L-N/G:740	L-N/G:900
LSP10480LLP	L-L:480	L-L:510	20,000	10,000	L-L:2020	L-L:2100
	L-N/G:277	L-N/G:320			L-N/G:1330	L-N/G:1400

Notes:

- 5A max. continuous current for series connection.
- Nominal Discharge Current (In)(A): The nominal discharge current is a measure of the SPDs endurance capability; 15 impulses of discharge current uses the 8/20us current waveform.
- Maximum Discharge Current (Imax)(A): The maximum discharge current is a measure of the SPDs maximum capability; single impulse of discharge current uses the 8/20us current waveform. All Devices pass maximum discharge current with possible, safe opening of thermal disconnect.
- MLV – UL1449 Measured limiting voltage; the highest value of residual voltage measurements during the application of impulses of 8/20us nominal discharge current (In); an average voltage value of 15 impulses.
- Up – IEC 61643-11 Voltage protection level; the highest value of residual voltage measurements during the application of impulses of 8/20us nominal discharge current (In); a rounding voltage value of maximum measurement.

Dimensions

Typical Dimensions (mm)

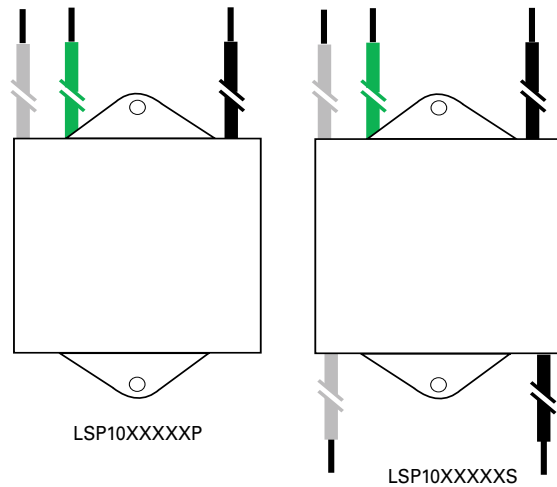
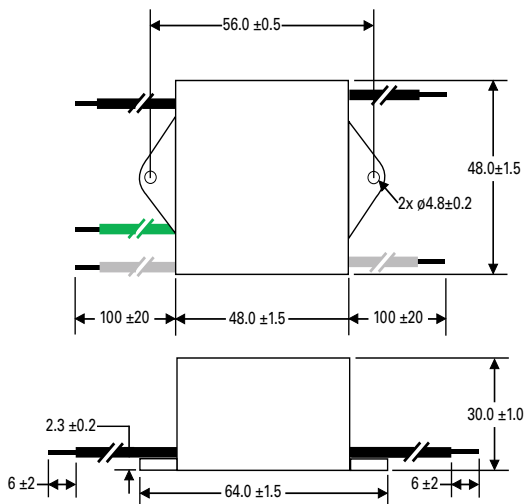

Notes:

- Black: Line; White: Neutral; Green: Ground.
(P/N with suffix X3333/X3316: Brown: Line; Blue: Neutral; Green-Yellow stripe: Ground)
- Wire Gauge: AWG14 wire Line in/out; Wire Length: 100mm or customized.

Application/Installation Schematic

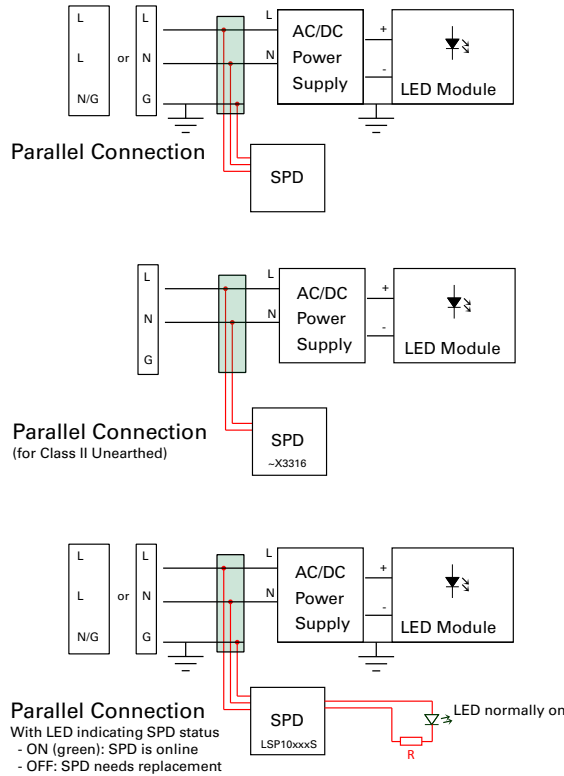

- Notes:
1. Series module used in parallel connection for indication circuit connection.
 2. LED indicator and associated circuitry are not included in the module.
 3. Black wire is AC line voltage (hot); white wire is AC neutral voltage.
 4. Black wire voltage is cut off when SPD needs replacement.
 5. R is current limiting resistor; its resistance/wattage is determined by AC line voltage and desired current driving LED. Example: AC line voltage 240V, LED: 1.6mA, resistor: 150Kohm/0.5W.

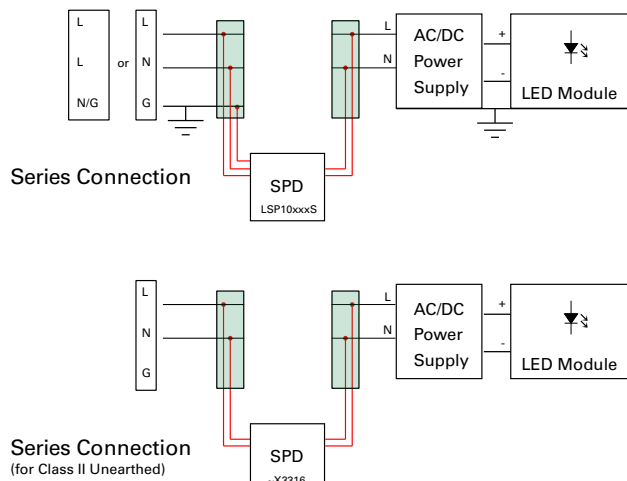

Part Numbering System

