



Main

Range of product	Magelis GTU
Product or component type	Flat screen
Terminal type	Touchscreen display
Integrated connection type	USB 2.0 type A USB 2.0 type mini B

Complementary

Function available	Brightness sensor
[Us] rated supply voltage	12...24 V DC power supply
Supply voltage limits	10.8...28.8 V
Power consumption	21 W
Display size	12.1 inch
Display type	Colour TFT LCD
Display resolution	1024 x 768 pixels XGA
Display colour	16 million colours
Backlight lifespan	50000 hours
Touch panel	Multi touch analogue resistive
Type of installation	Indoor installation
Type of cooling	Natural convection
Inrush current	30 A
Cut-out dimensions	301.5 (+ 1/- 0) x 227.5 (+ 1/- 0) mm
Width	315 mm
Height	241 mm
Depth	67 mm
Product weight	3 kg

Environment

IP degree of protection	IP67 (front panel) IP66 (front panel)
NEMA degree of protection	NEMA 4X (front panel)
Standards	IEC 61132-2 CSA C22.2 No 142 CSA C22.2 No 213 class I division 2 ANSI/ISA 12-12-01 UL 508
Product certifications	CE CULus RCM KC
Ambient air temperature for operation	0...60 °C
Ambient air temperature for storage	-20...60 °C
Pollution degree	2
Relative humidity	10...90 % (non-condensing)

Operating altitude	2000 m
Vibration resistance	9.8 m/s ² (f = 9...150 Hz) conforming to EN/IEC 61131-2 3.5 mm constant amplitude (f = 5...9 Hz) conforming to EN/IEC 61131-2
Shock resistance	147 m/s ² conforming to EN/IEC 61131-2
Electromagnetic compatibility	Electrostatic discharge immunity test conforming to EN/IEC 61000-4-2 level 3

Offer Sustainability

Sustainable offer status	Green Premium product
RoHS (date code: YYWW)	Compliant - since 1347 - Schneider Electric declaration of conformity
REACH	Reference not containing SVHC above the threshold
Product environmental profile	Available Download Product Environmental
Product end of life instructions	Available Download End Of Life Manual

External Dimensions

Display Unit with Box Module

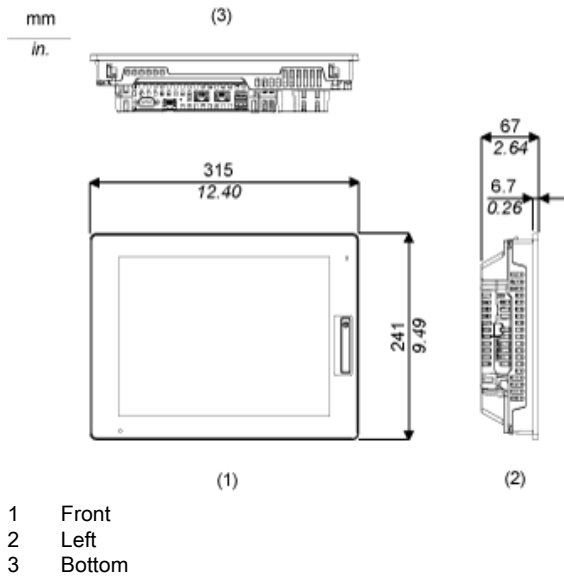

Installation with Installation Fasteners and Dimensions with Cables

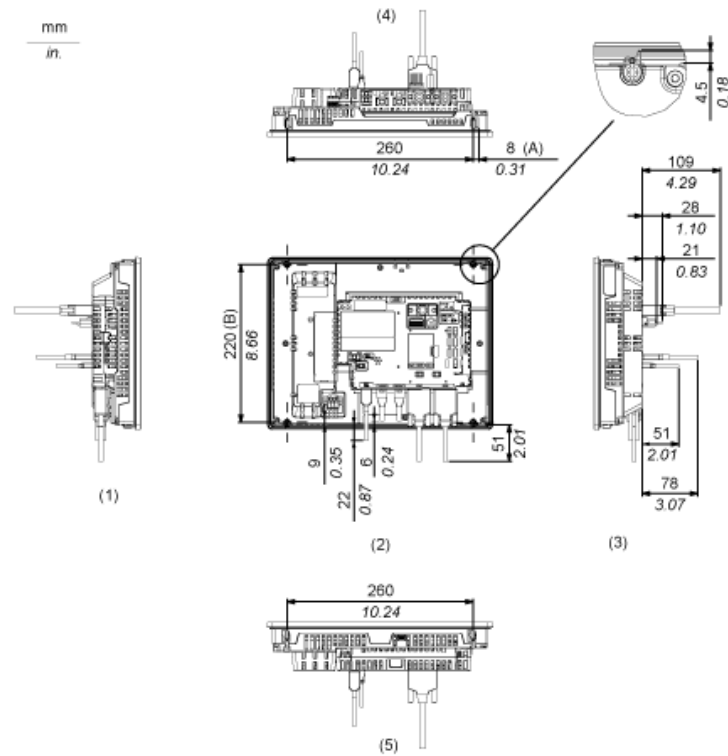

- (A) Rotation area of the fastener
(B) Pitch of the center of installation fastener screws
1 Right
2 Front
3 Left
4 Bottom
5 Top

Mounting

Panel Cut Dimensions

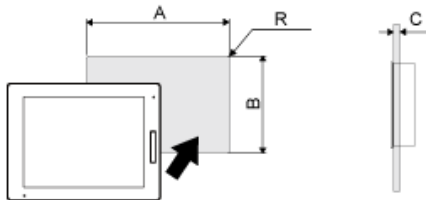

Dimensions in mm

A	B	C	R
301.5 (+1/-0)	227.5 (+1/-0)	1.6...5	3 max.

Dimensions in in.

A	B	C	R
11.87 (+0.04/-0)	8.96 (+0.04/-0)	0.06...0.2	0.12 max.

Installation Requirements

Mounting Angle

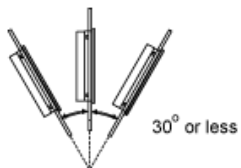

When installing this product in a slanted position with an incline more than 30°, the ambient temperature must not exceed 40 °C (104 °F). You may need to use forced air cooling (fan, A/C) to ensure the ambient operating temperature is 40 °C or less (104 °F or less).

Clearance

