

# KDC2710LEVAL, KDC2710CEVAL, KDC2708LEVAL, KDC2708CEVAL

## KDC2710LEVAL, KDC2710CEVAL, KDC2708LEVAL, KDC2708CEVAL Schematic

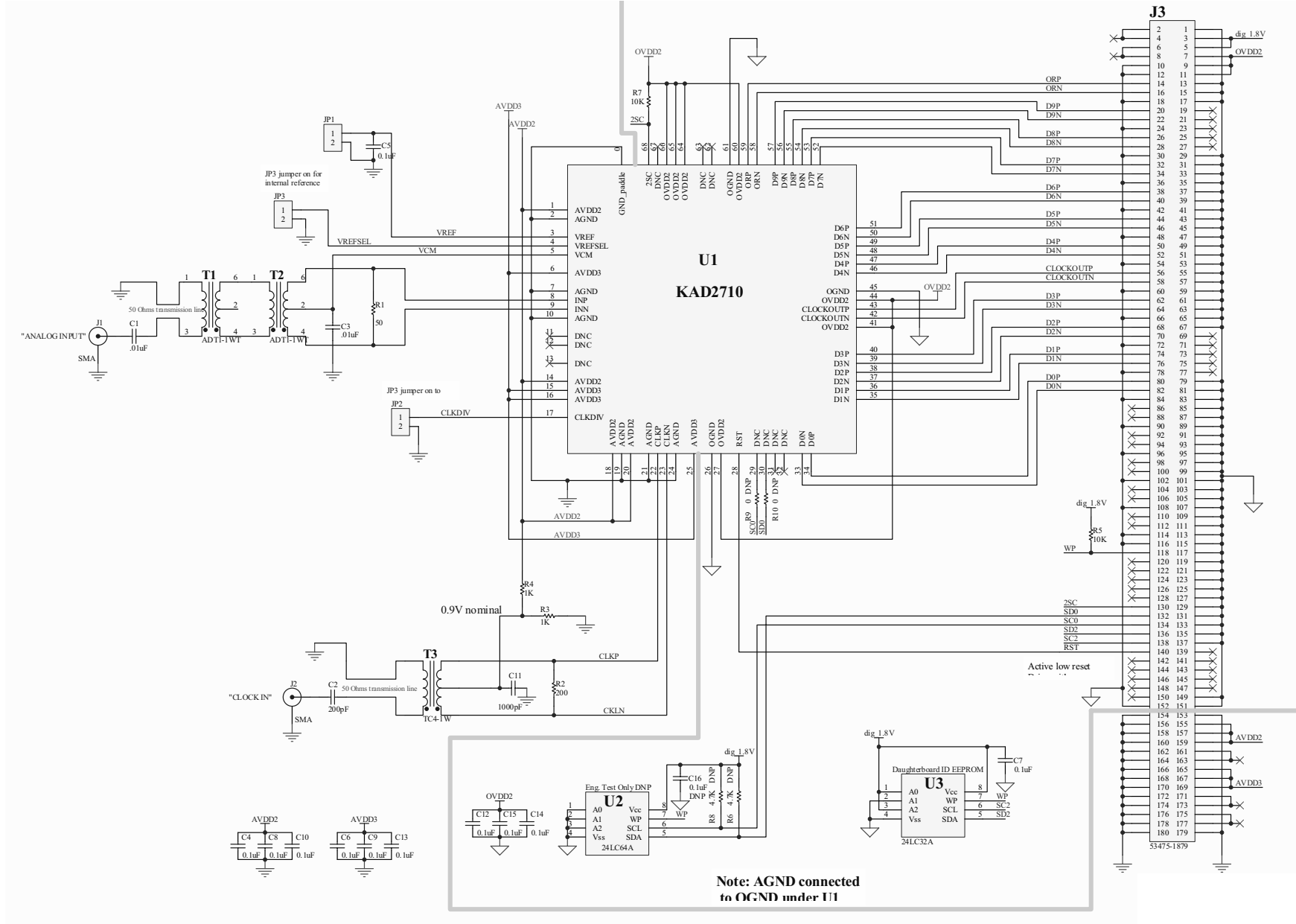

FIGURE 1. ENTIRE DAUGHTER CARD SCHEMATIC

KDC2710LEVAL, KDC2710CEVAL, KDC2708LEVAL, KDC2708CEVAL Layers

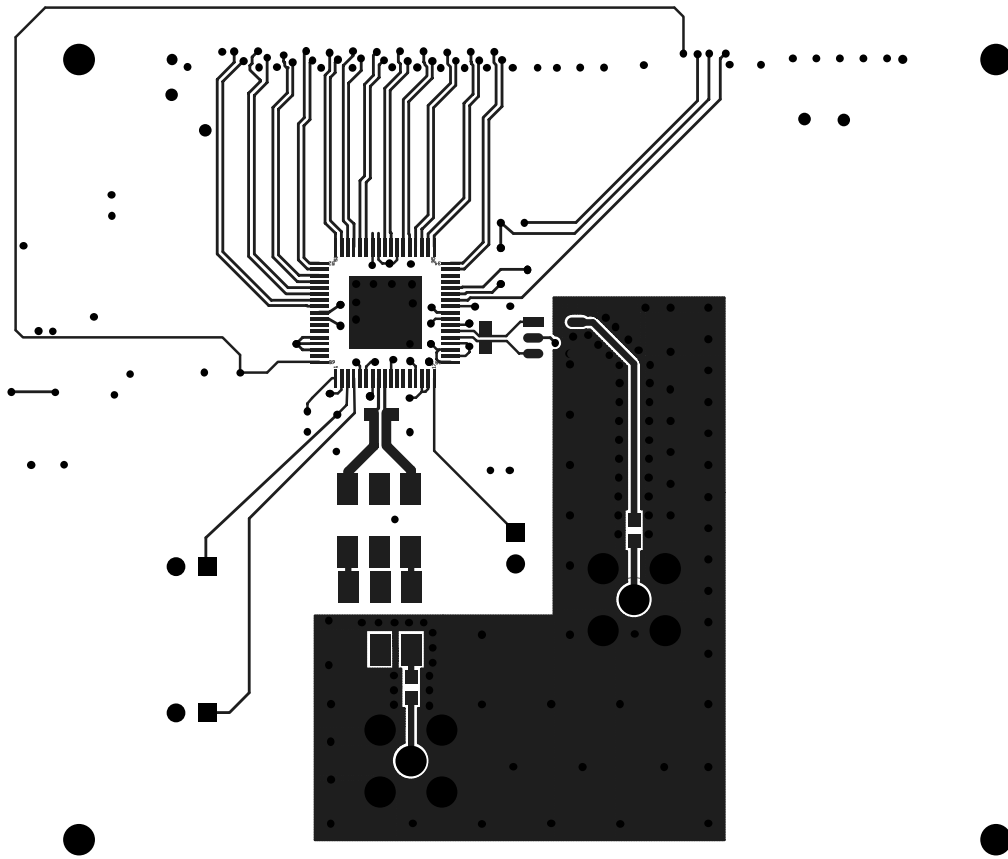

FIGURE 2. PRIMARY SIDE

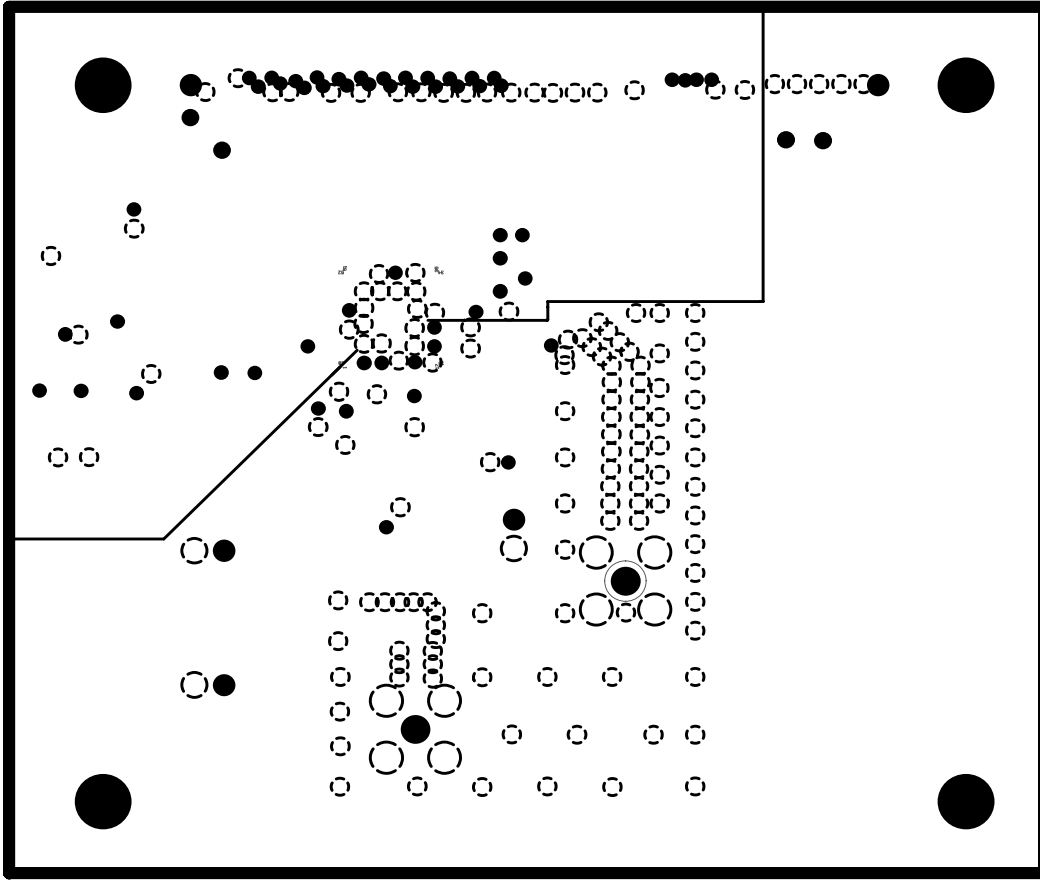

FIGURE 3. INTERNAL GROUND PLANE

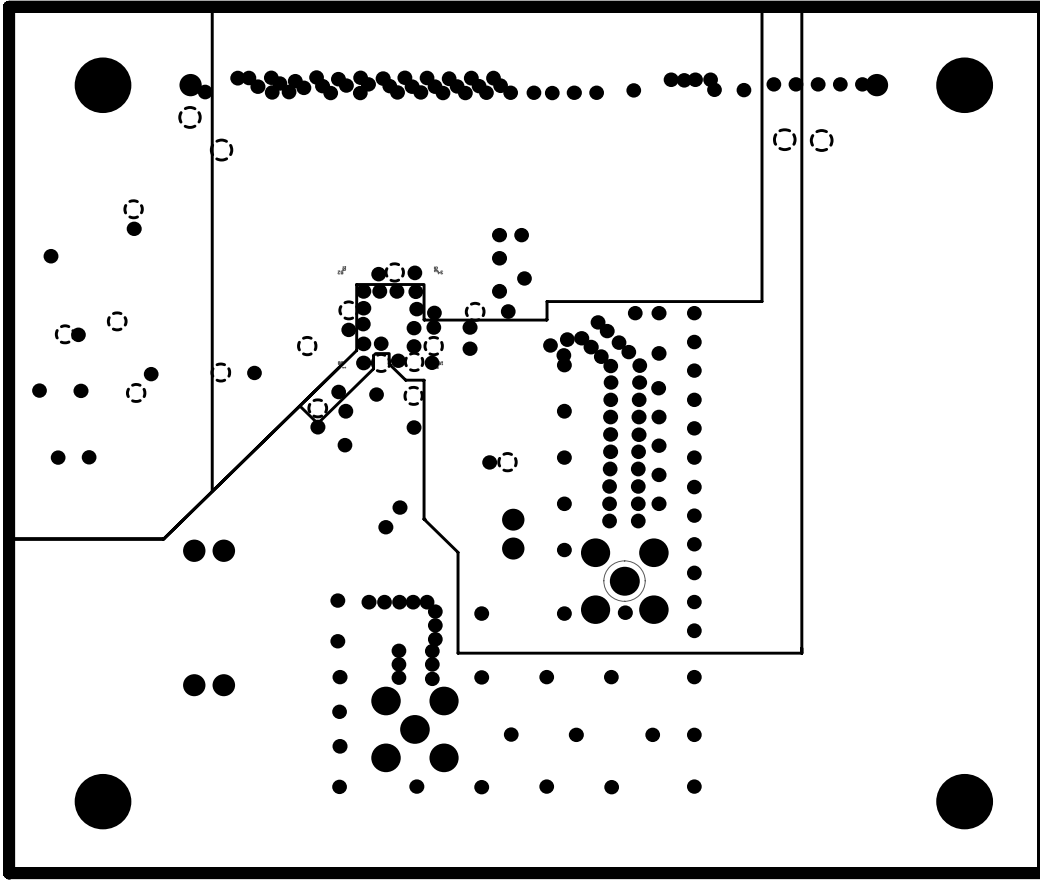

FIGURE 4. INTERNAL POWER PLANE

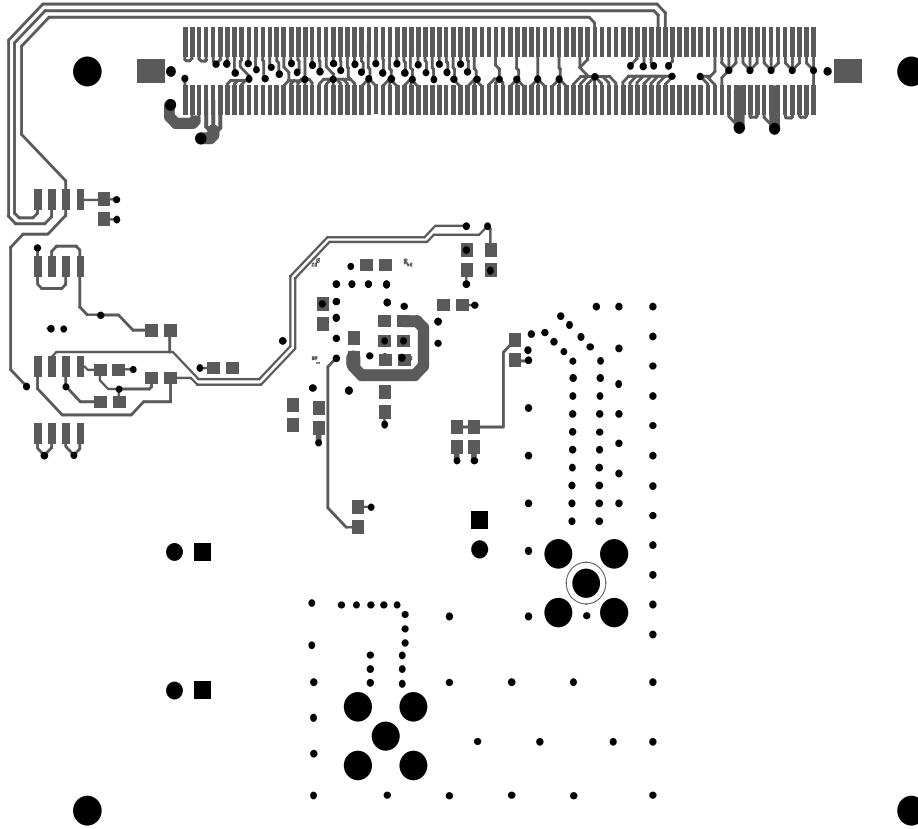

FIGURE 5. SECONDARY SIDE

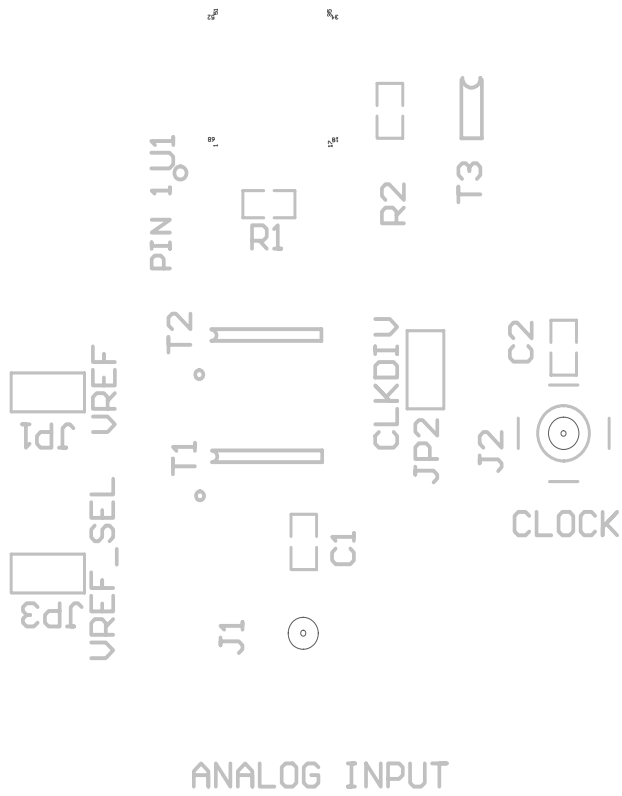

FIGURE 6. PRIMARY SIDE SILKSCREEN

KDB-2710-L REV 02

KDC2710LEVAL, KDC2710CEVAL, KDC2708LEVAL, KDC2708CEVAL Layers (Continued)

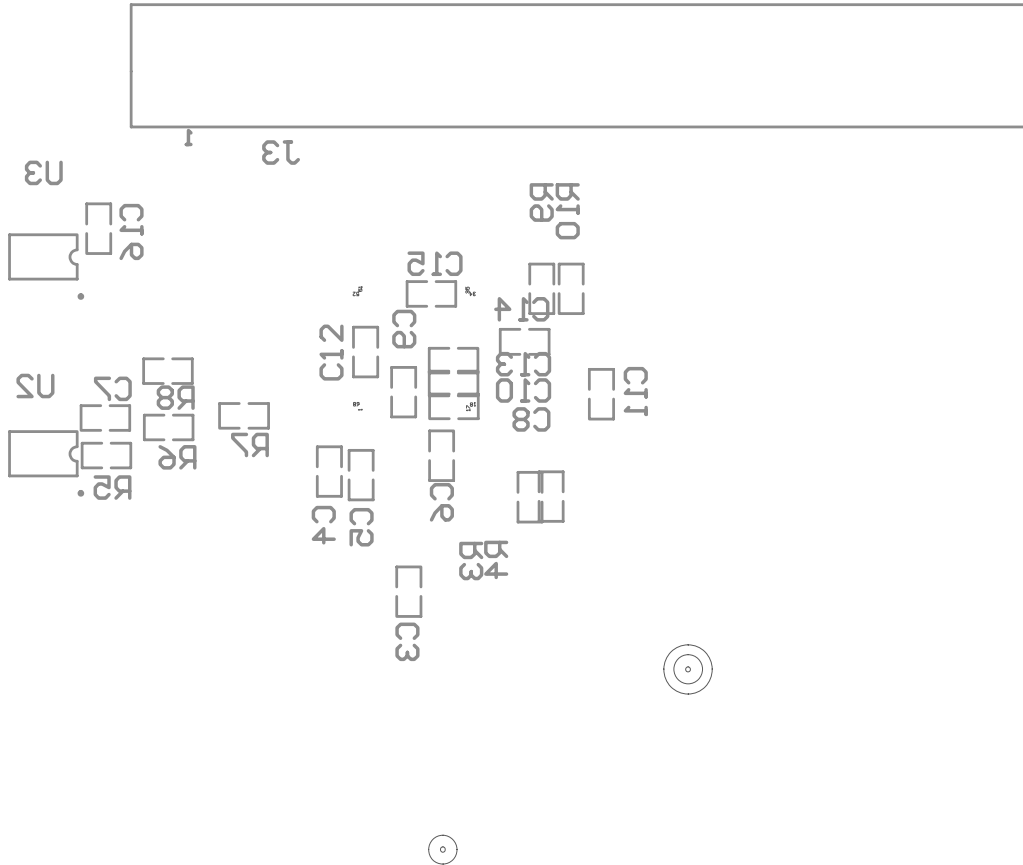

FIGURE 7. SECONDARY SIDE SILKSCREEN

Intersil Corporation reserves the right to make changes in circuit design, software and/or specifications at any time without notice. Accordingly, the reader is cautioned to verify that the Application Note or Technical Brief is current before proceeding.