

10112684 - X XX-YY Z LF

INDICATES THAT PRODUCT IS RoHS COMPATIBLE, SEE NOTE 3

PACKAGING :

A = Tape and reel with Pick-up cap.
See GS-14-1516 As available
U = Tube without Pick-up cap.
Only for contacts qty from 4 to 25.
See GS-14-1551
Blank = Bli box for contacts qty 2 and 3
See note 5

CONTACTS QTY : 02 to 25 = N

STYLE	01	02	03
DIM C POST LENGTH	3.2	2.0	4.0

PLATING : G= 0.76 μ Gold/GXT on mating area
2-6 μ Pure Tin on solder area
F= Gold flash on mating area
2-6 μ pure Tin on solder area
T= 2-6 μ pure Tin on mating area
2-6 μ pure Tin on solder area
All with 1.27 Ni underplating

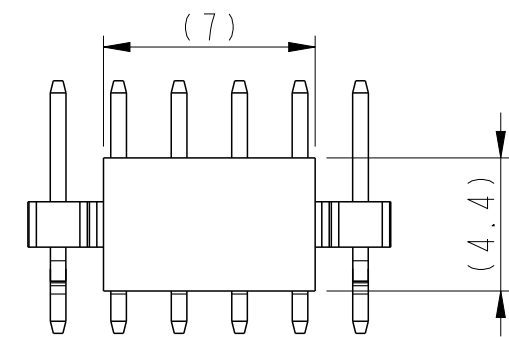
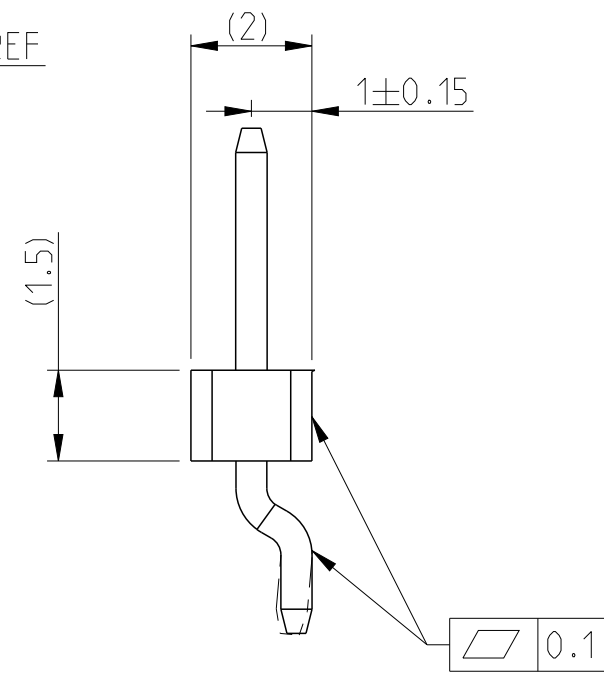
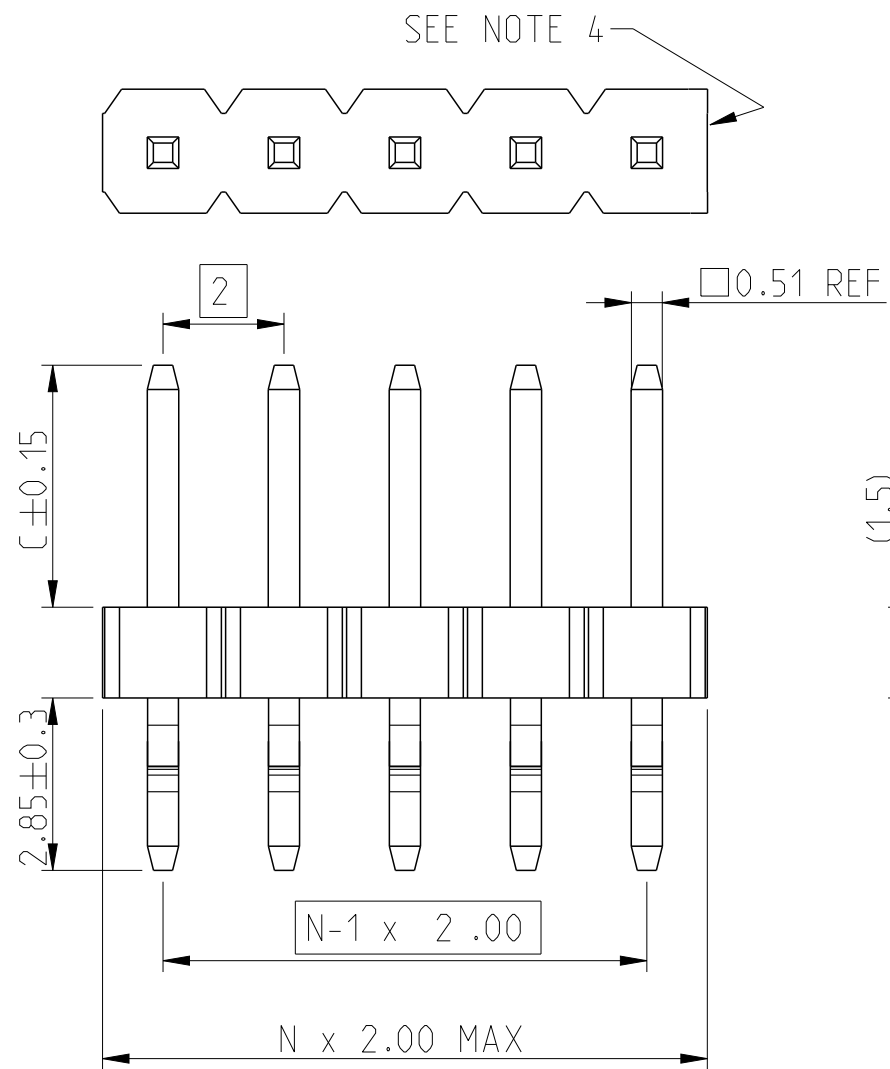

VIEW WITH PICK-UP CAP
SCALE 4:1

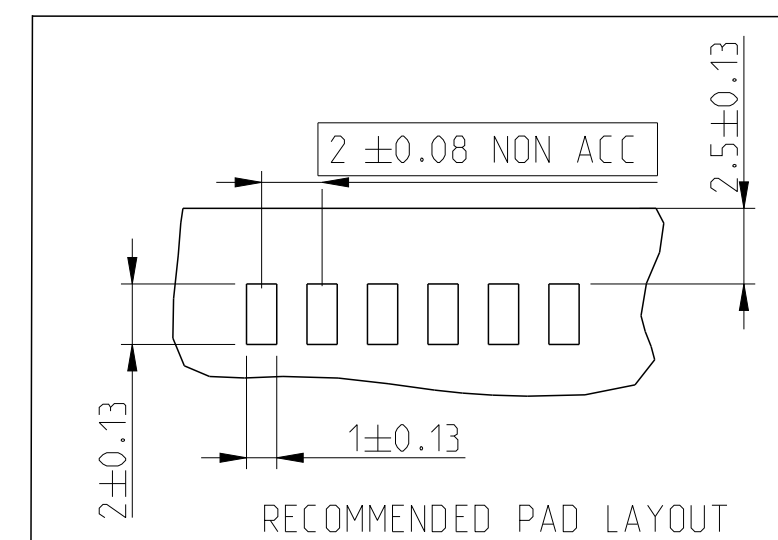

- NOTES :
- 1- MATERIALS :
BODY : High Temp thermoplastic 30% GF, COLOR BLACK UL94 V-0
PIN : COPPER ALLOY
 - 2- 7N MIN PIN RETENTION IN EITHER DIRECTION
 - 3- RoHS COMPATIBLE PRODUCT SPECIFICATION :
a- PLATING : LF means the product is Lead Free,
2 μ MIN matte Tin over 1.27 μ Nickel underplating.
b- MANUFACTURING PRODUCT SPECIFICATION :
Housing will withstand exposure to 260 °C peak temperature for 30 seconds in a convection infra-red or vapor phase oven.
c- LABELLING :
Meets packaging specs as per GS-14-920
d- LEGAL STATMENT : See GS-47-0004
 - 4- ONE TIP OF BODY MIGHT BE WITHOUT INDENTS AS PER EXTREMITY OF MOLDED BODY.
 - 5- MINIMUM QUANTITY IN BLI BOX : 500

spec ref	GS-12-652	dr	A Parrenin	2014/02/28	projection	mm	size	A3	scale	8:1	
tolerance std	ISO 406 ISO 1101	eng	A Parrenin	2014/03/18			ecn no	ELX-B-17233-1	rel level	Released	
TOLERANCES UNLESS OTHERWISE SPECIFIED		chr	D Convercey	2014/03/19							
surface	ISO 1302	appr	Gert Drosbeke	2014/03/21	product family		rel level				
linear	0.X ±0.30 0.XX ±0.13 0.XXX ±0.05			title	UNSHROUDED HEADER SMT		dwg no	10112684C		rev	D
angular	0° ±/°	www.fci.com	cat. no.	-	Product - Customer Drw	sheet 1 of 1					

Copyright FCI. FCI