

RECOMMENDED PANEL MOUNTING

PANEL THICKNESS	X
1-2	31 +.1/-0
2-2.5	31.6 +.1/-0

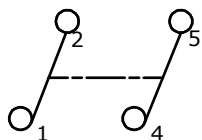
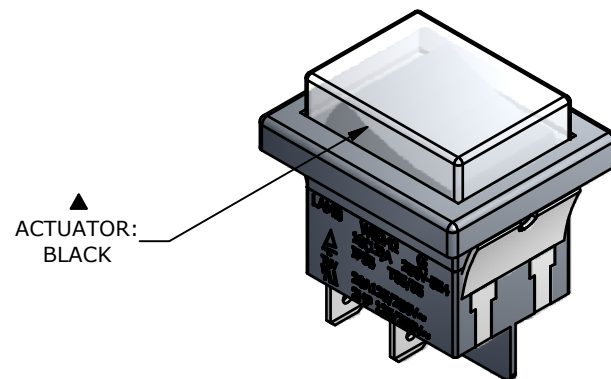
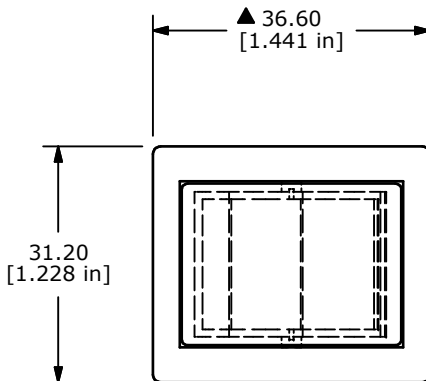

CIRCUIT: DPST

SWITCH FUNCTION	
POS. 1	POS. 2
OFF	(ON)
OPEN	2-1, 5-4

(ON)=MOMENTARY

NOTE:

- DIMENSIONS IN mm [INCH]
- GENERAL TOLERANCE: X.X = ± 0.4
X.XX = ± 0.25
- TERMINAL NUMBERS FOR REF ONLY
- CONTACT MATERIAL: SILVER PLATED COPPER
- CONTACT RATINGS: 20A @ 125VAC [cURus]
20A @ 250VAC [cURus]
1.5HP 125/250VAC
- CONTACT RESISTANCE: 50mΩ MAX. INITIAL
- INSULATION RESISTANCE: 500MΩ MIN. @ 500VDC
- DIELECTRIC STRENGTH: 1,500VAC FOR 1 MINUTE
- IP RATING: IP55
- OPERATING TEMPERATURE: -20°C TO 65°C [cURus]
-20°C TO 65°C [TUV]
- RUBBER SEAL: MVQ
- ▲ DENOTES CRITICAL PARAMETER
- 2002/95/EC (ROHS) COMPLIANT

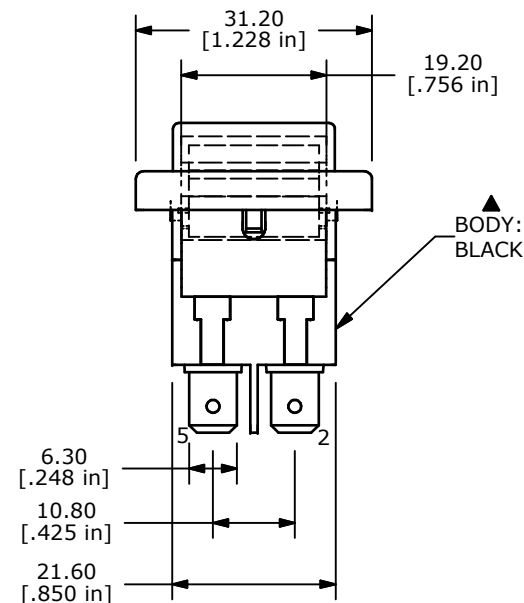
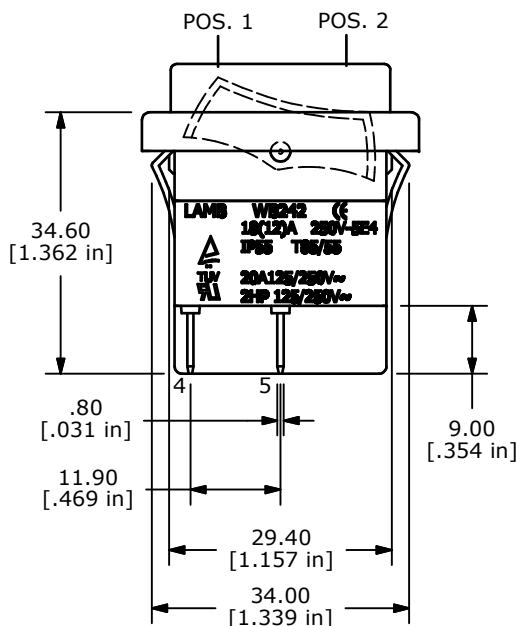

TITLE WB24ED1100-ACC-KF05				
SCALE	DATE	DR	DWG	REV
NONE	3/22/2012	MM	34-WB2S00223	B

THE INFORMATION CONTAINED IN THIS DOCUMENT IS PROPRIETARY TO E-SWITCH AND IS NOT TO BE COPIED OR TRANSFERRED

B	20634	RMD DIMENSION, CHD 1.5HP WAS 2HP	06/07/12	drg
A	20582	New Release	4/30/12	mm
REV	PCR NO	DESCRIPTION	DATE	BY