

## PRODUCT OVERVIEW

The PEM1200 series of power extraction modules, have complete compliance with the IEEE 802.3af Power-Over-Ethernet (PoE) standard, and are designed to extract power from CAT5 Ethernet cable when sourced by a IEEE 802.3af compliant Power Sourcing Equipment (PSE).

With the increasing demand for “**Green Power**” IEEE has emphasized the need for power “*right-sizing*”. The PEM1200 series Powered Device (PD) modules provides full PoE signature and programmable power classification for granular power management.

Its high efficiency DC-DC converter provides a well regulated low noise and low ripple output with in-built overload and output short-circuit protection.

The PEM1200 series provides a quick, easy, and low cost method for Ethernet equipment manufacturers to “PoE enable” their equipment.

## PRODUCT FEATURES

- Fully IEEE 802.3af compliant
- 12.95 watt output load<sup>1</sup>
- IEEE Power class programmable (Green)
- 1500 Volt DC isolation (Input to Output)
- 3.3V, 5V, 12V DC output voltage models
- Compact package minimum PCB footprint
- Minimal external components required
- Overload and short circuit protection<sup>2</sup>
- Wide input voltage (36V to 57V DC)
- Adjustable output voltage
- RoHS 2002/95/EC compliant
- Low output ripple and noise
- Low cost



<sup>1</sup> In 5V and 12V model

<sup>2</sup> If maximum power is exceeded, the PEM1200 will operate in over current mode and will auto recover when the over load condition is removed.

PRODUCT SELECTOR					
Part Number	Marking	Nominal Input Voltage	Output Voltage <sup>3</sup>	Efficiency <sup>4</sup>	Power (Maximum) <sup>6,7</sup>
		(Volts DC)	(Volts DC)	(%)	(Watts)
PEM1203	3	48	3.3	80	10
PEM1205	5	48	5	82	12.95
PEM1212	12	48	12	86	12.95

ABSOLUTE MAXIMUM RATINGS <sup>5, 6</sup>	
Supply Voltage (V <sub>CC</sub> )	0V – 57V DC
Storage Temperature (T <sub>s</sub> )	-25 °C – 100 °C
Output Voltage (V <sub>OUT</sub> )	0V to controlled output voltage (operating or non-operating)

INPUT CHARACTERISTICS						
Parameter	Symbol	Min.	Typ <sup>4</sup> .	Max.	Units	
Input Voltage <sup>7</sup>	V <sub>IN</sub>	36	48	57	Volts	
Under Voltage Lockout	V <sub>UVLO</sub>	30		36	Volts	
Input Current <sup>8, 10</sup>	I <sub>IN</sub>		350	400	mA	
Operating Temperature <sup>9</sup>	T <sub>OP</sub>	-20	25	70	°C	
IEEE 802.3af Power Classification <sup>10</sup>	Programmable Class 0, 1, 2, or 3					

DC OUTPUT CHARACTERISTICS						
Parameter	Symbol	Min.	Typ <sup>4</sup> .	Max.	Units	
Line Regulation <sup>8</sup>	V <sub>LNRG</sub>		0.2%			
Load Regulation <sup>8</sup>	V <sub>LDRG</sub>		0.5%			
Output Ripple and Noise <sup>5, 8</sup>	V <sub>RIP</sub>		80		mV p-p	
Isolation Voltage	V <sub>ISOL</sub>			1500	V DC	
Temperature Coefficient (Slope)	TC		100	300	ppm °C	

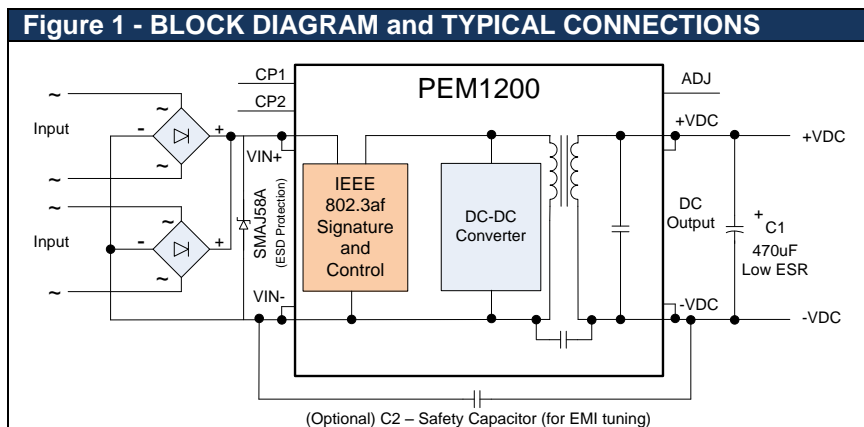

<sup>3</sup> Output voltage typical  $\pm 3\%$  at T<sub>A</sub> of 25°C with a nominal input voltage and rated output current.

<sup>4</sup> At nominal Vin at 67% load

<sup>5</sup> All specifications typical are at T<sub>A</sub> of 25°C with a nominal input voltage and rated output current unless otherwise noted. These are meant as a design aid only and are indicative, and not guaranteed.

<sup>6</sup> Exceeding the absolute maximum ratings may cause permanent damage to the product. We do not imply functional operation under these conditions. These ratings assume free air flow.

<sup>7</sup> With minimum load 100mA

<sup>8</sup> Please refer to IEEE802.3af standards document. Maximum input current is dependent on power class, and input voltage. Input current (DC or RMS) at V<sub>PORT</sub> =37VDC is 350mA, at V<sub>PORT</sub> =57VDC is 230mA. Peak inrush current is 400mA for 50mS max at duty cycle of 5% max.

<sup>9</sup> Please see section F.6. – Thermal profile on operating temperature

<sup>10</sup> Please see section F.2 – Powered Device Signature and Class programming for more details

## FUNCTIONAL DESCRIPTION

### F.1. Inputs

The PEM1200 is compatible with all IEEE 802.3af compliant Power Sourcing Equipment (PSE) and supports the different power injection options of Data/Signal pair (Mode A) or Spare Pair (Mode B). See Figure 2 – Typical System Configuration. As per IEEE 802.3af, it is specified that the PSE does not apply power to the both outputs at the same time i.e. 4 pair injection. (Refer to IEEE802.3af standards for more information).

The PEM1200 provides for external input bridge rectifiers for improved system design flexibility, and distribution of heat generation. As an example, a system designer wanting to provide two RJ45 inputs, both of which are PoE enabled, but use only one PEM1200 module to save costs. Another advantage is that this allows the system designer to control the type and costs of the input rectification diodes.

### Figure 2 – Typical System Configuration

In Mode A – Signal Pair injection, the signal lines carry both data and power. In Mode B – Spare Pair injection, the Signal pair carries only data, and the spare pair carries power.

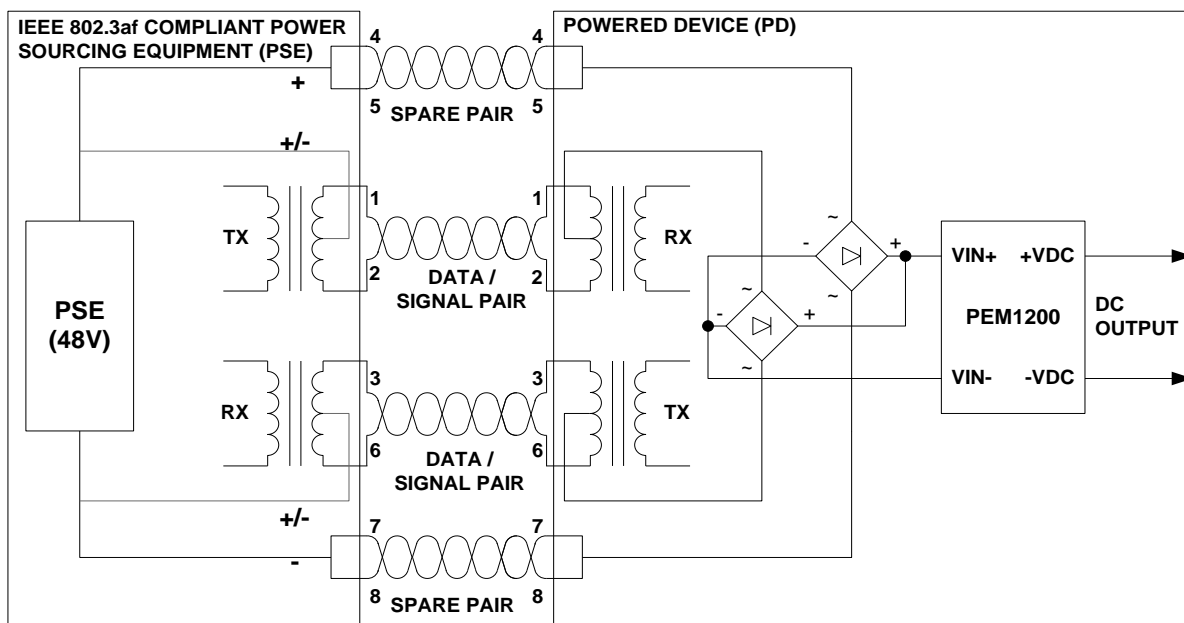

### F.2. Powered Device (PD) Signature and Power Classification

When the PEM1200 is connected to a Cat 5e or greater Ethernet cable from an IEEE 802.3af compliant Power Sourcing Equipment (PSE), Endspan or Midspan, it will automatically present a Powered Device (PD) signature to the PSE, as and when requested. The PSE will then recognise that a PD is connected to that line and supply power. With the growing emphasis on “Green Power”, in the latest standard, IEEE has stressed for PDs to implement the IEEE 802.3af **Power Classification** system to ensure correct provisioning of power from the PSE. To help in proper power level provisioning and improved power management, the IEEE 802.3af standard provides for PDs to inform the PSE their required power levels via a Class system. The classes are defined as per Table 1 below. The PEM1200 allows for programming the Class by placing a 1/16W or greater and 1% tolerance resistor detailed in Table 1.

Table 1 – Power Classification programming			
PoE Power Class	Required PD Power	1/16W or greater and 1% tolerance resistor between	
		Pin 4 (Vin –) and Pin 6 (CP2)	Pin 5 (CP1) and Pin 6 (CP2)
0	0.44W ~ 12.95W	Do not connect	Any value 10KΩ to 100 KΩ
1	0.44W ~ 3.84W	280kΩ	Do not connect
2	3.84W ~ 6.49W	143kΩ	Do not connect
3	6.49W ~ 12.95W	90k9kΩ	Do not connect
4	Reserved for 802.3at	Reserved	Reserved

**Important :** Do not connect Pin 4 to Pin 5 at any time. Do not connect Pins 4 and 5 and 6 at the same time. Connect Pin 5 only to Pin 6 and only as per Table 1. Pin 5 and 6 may be left unconnected for default Class 0 but is not recommended.

### F.3. Isolation

IEEE802.3af section 33.4.1 calls for a Powered Device (PD) to meet safety isolation requirement by meeting the electrical strength test of IEC 60950 sub clause 6.2. Infomart's® PoweredEthernet™ PEM1200 modules meet or exceed 1500V impulse test. This is also referred to as 'Hi Pot Test', 'Flash Tested', 'Withstand Voltage', 'Proof Voltage', 'Dielectric Withstand Voltage' & 'Isolation Test Voltage'.

## F.4. Output Voltage Adjustment

The PEM1200 series has an OADJ pin, which allows the output voltage to be increased or decreased from its nominal value using a 1/16W power rating or greater and 1% tolerance resistor connected between the OADJ pin and either the +VDC or -VDC pin as per figures below. Only one connection i.e. between OADJ and +VDC or between OADJ and -VDC is permitted at a time. A change of more than  $\pm 10\%$  from nominal is not permitted. Please [contact Infomart technical support](#) for more details or specific resistor values.

Figure 3

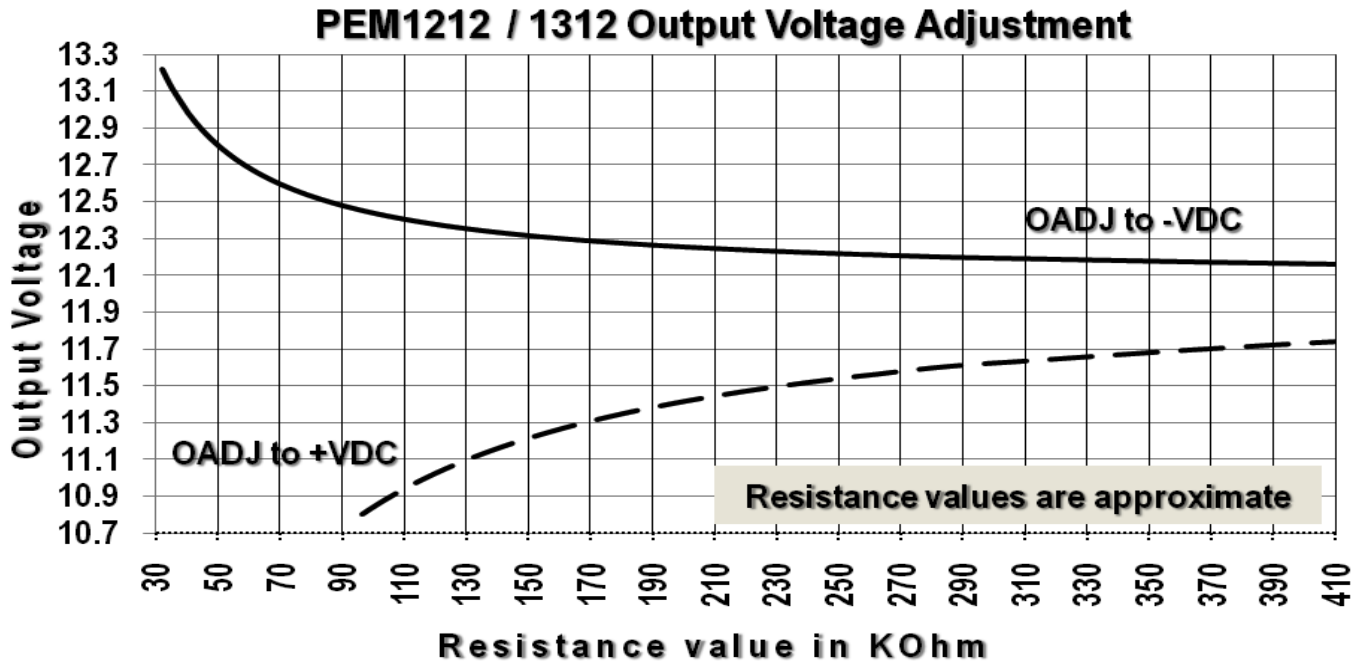

Figure 4

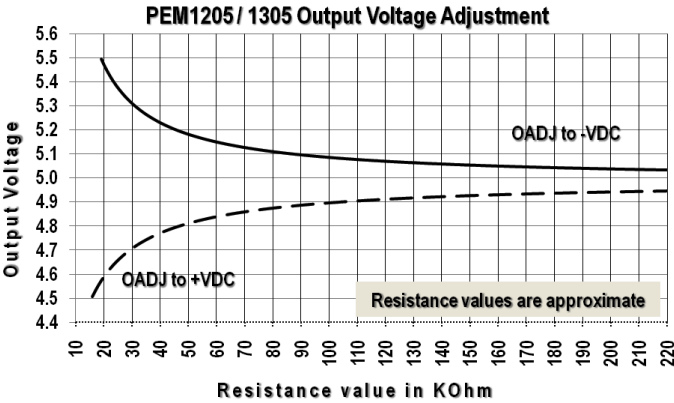
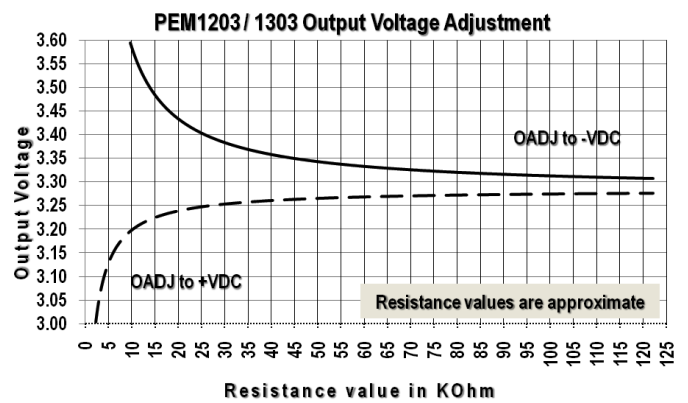

Figure 5



## F.5. Pin Connections

INPUT PINS		OUTPUT PINS	
1	<b>VIN+</b> . This pin connects to the positive (+) output of the input bridge rectifiers (internally connected to pin 3).	7	<b>-VDC</b> . The ground return for the +VDC output. Max. current 3A per pin.
2	<b>VIN-</b> . This pin connects to the negative (-) output of the input bridge rectifiers (internally connected to pin 4).	8	<b>+VDC</b> . This pin provides the regulated output from the DC/DC converter. Max. current 3A per pin.
3	<b>VIN+</b> . This pin connects to the positive (+) output of the input bridge rectifiers (internally connected to pin 1).	9	<b>OADJ</b> . The output voltage can be adjusted from its nominal value, by connecting an external resistor from this pin to either the +VDC pin or the -VDC pin. For more details please see section F.4.
4	<b>VIN-</b> . This pin connects to the negative (-) output of the input bridge rectifiers (internally connected to pin 2).	10	<b>NC Do not connect</b>
5	<b>CP1</b> . Connect this pin only as per instructions in Table 1.	To maintain isolation integrity, always connect respective input and output poles only via X or Y safety capacitor. Maintain isolation barrier on motherboard PCB as per physical package.	
6	<b>CP2</b> . Connect this pin only as per instructions in Table 1.		

**Figure 6 – PHYSICAL PACKAGE**

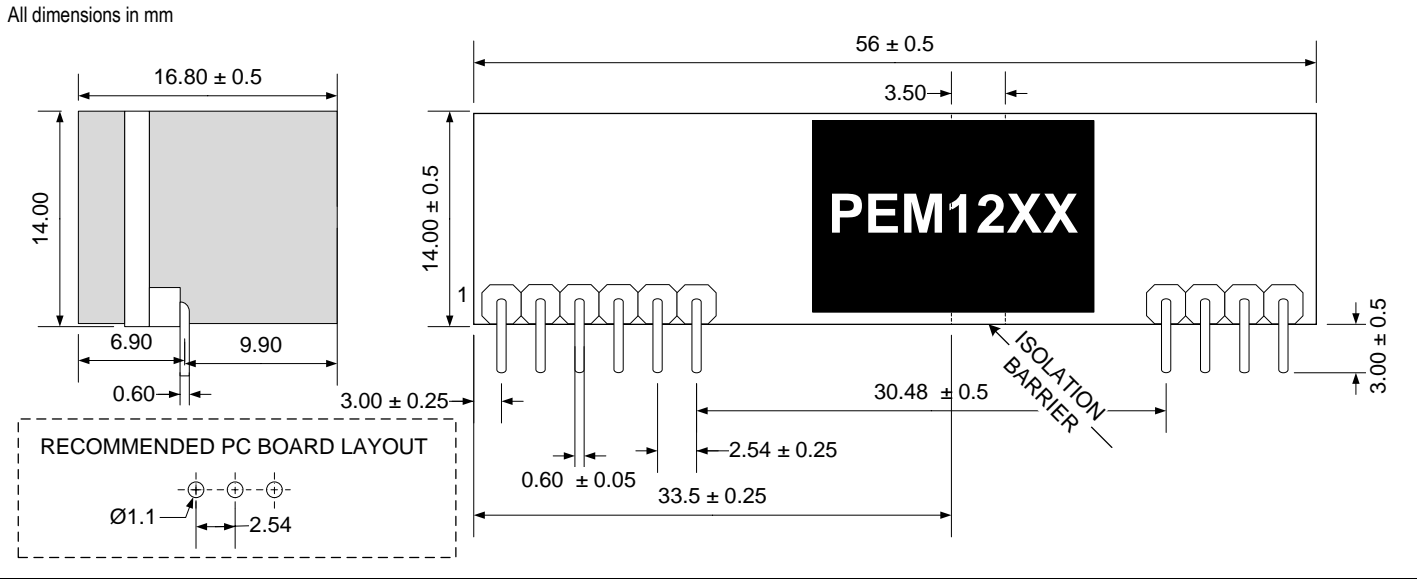

## THERMAL PROFILE

### F.6. Heat Generation

As with any power component, the PEM1200 modules generate heat. It is important that adequate ventilation and airflow be taken into consideration at the design stage. The quantum of heat generated by the PEM1200 will depend on the output load it is required to drive. The maximum ambient operating temperature is 70°C. Figure 7 below, shows the thermal performance of the PEM1200 with a nominal 48VDC input. The PEM1200 thermal performance can be improved by forced airflow cooling over the module and by using a heat sink (a) glued on to the output diodes using a thermal glue, or (b) by a power plane heat sink described in Figure 8 below. The two methods can be combined.

**Figure 7 – Thermal Performance profile at nominal  $V_{in}$**

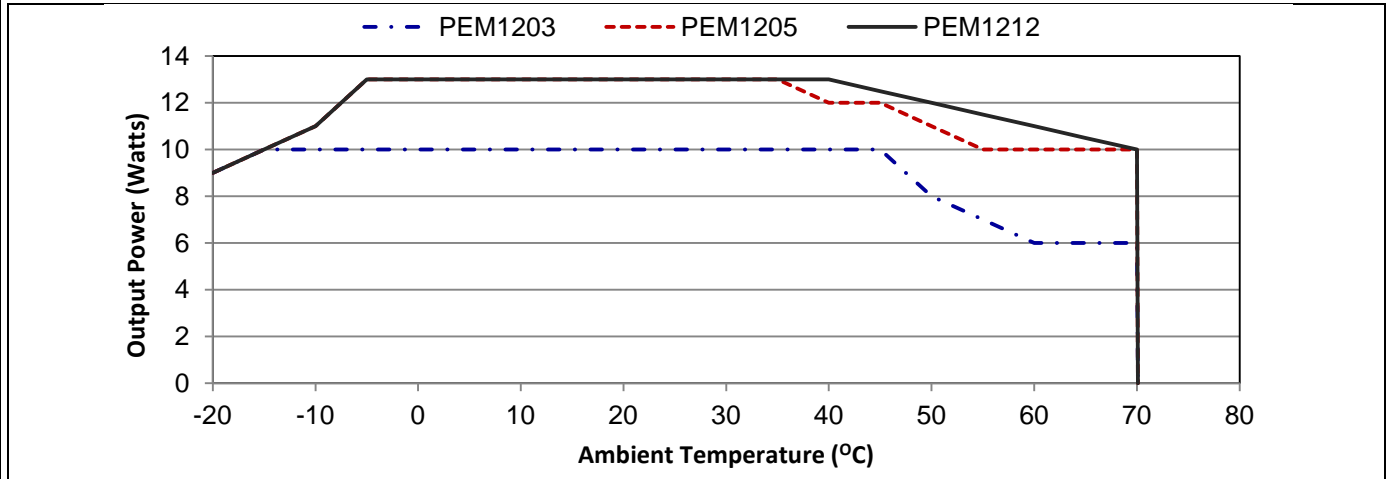

**Figure 8 – Power Plane Heat Sink**

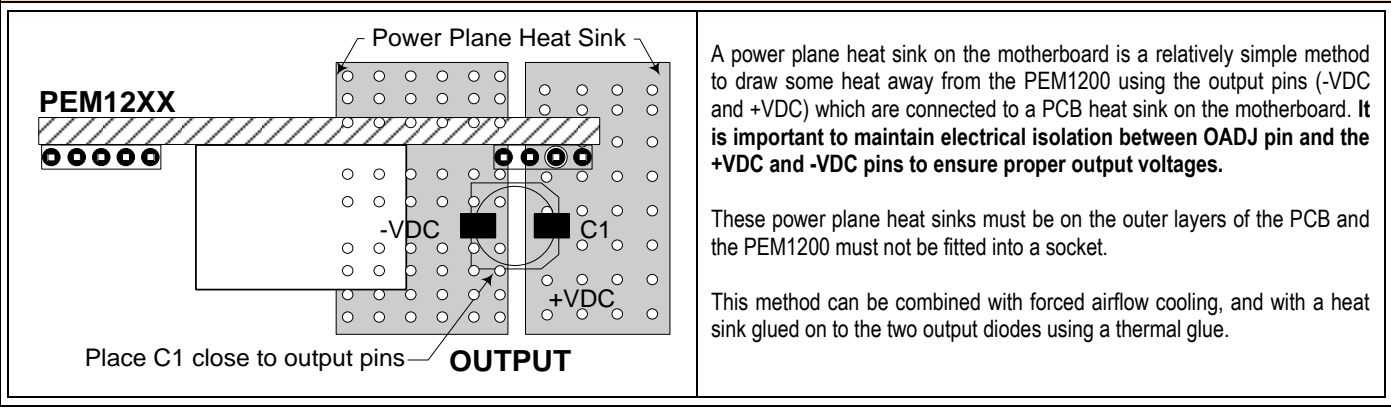

## APPLICATION NOTES

Power Over Ethernet (PoE) is a technology for wired Ethernet, the most widely installed local area network technology in use today. PoE allows the electrical power necessary for the operation of each end-device to be carried by data cables along with the data, rather than by separate power cords. Thus, it minimizes the number of wires used to install the network, resulting in lower cost, less downtime, easier maintenance and greater installation flexibility.

The IEEE standard governing PoE is IEEE802.3af. Compliance with this standard ensures inter-operability between devices.

The PEM1200 series modules offering a modular solution, incorporating full IEEE802.3af compatibility signature to the PSE and isolated on-board DC/DC converter. The PEM1200 series are ideal modular system blocks allowing manufacturers of Ethernet equipment to "PoE enable" their equipment with minimal effort and cost. The PEM1200 modules series offer simple and quicker product development, maximising return on investment.

PEM1200 can be powered using a user designed power supply which has adequate thermal and over-current protection. It is strongly recommended that only IEEE802.3af compliant power supply equipment be used to prevent damage to the module, which lacks output stage thermal protection .

**ESD Protection:** It is required that the system designer must provide ESD protection such as an SMAJ58A (uni-directional) or SMAJ58CA (bi-directional) TVS diode at the PEM1200 input(s) to prevent damage from over-voltage surges and for system EMC compliance.

## APPLICATION AREAS

- Security and alarm systems
- Voice over IP phones
- Access control systems
- IP Cameras
- Displays, Net Monitors
- Public address systems
- Wireless access points
- Environmental control
- Telemetry
- Remote environmental monitoring

**Figure 9 – Sample PoE System Configuration**

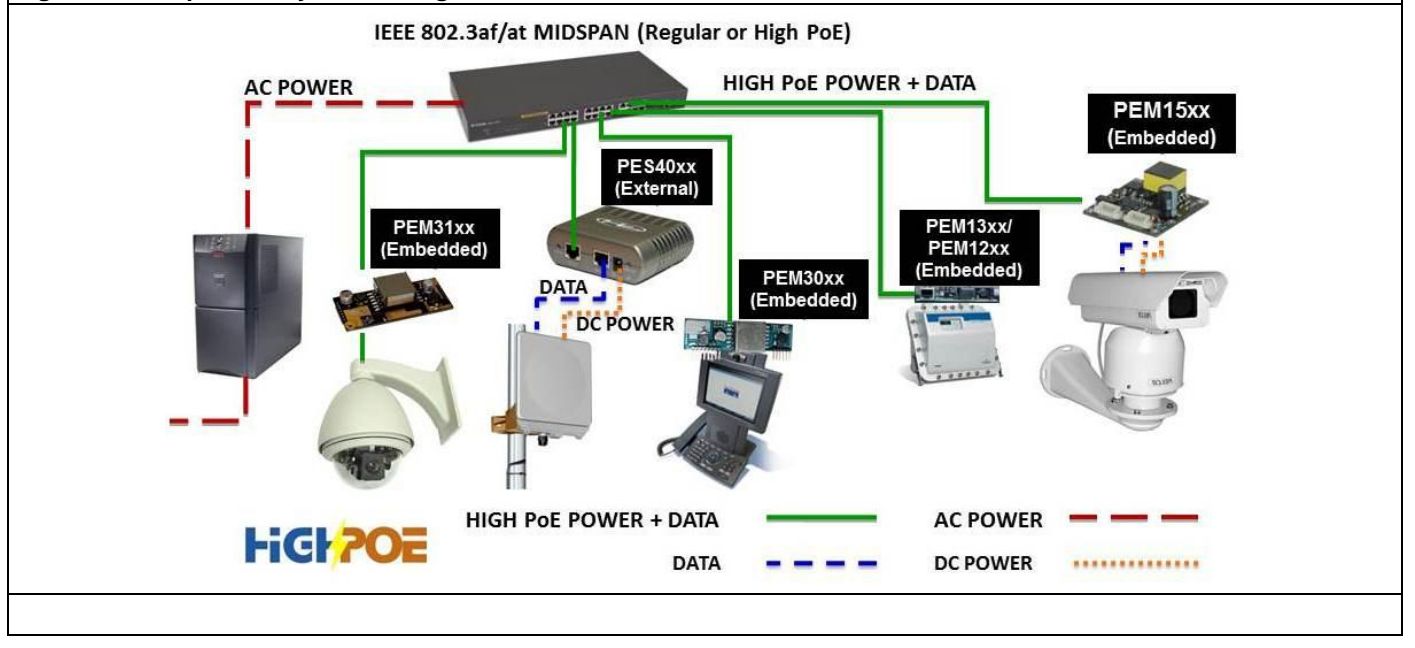

**Infomart Asia Pacific Pte. Ltd.**  
 1, North Bridge Road #19-04  
 High Street Centre  
 Singapore 179094  
 Tel : +65 6225-6500

**Infomart India Pvt. Ltd.**  
 Infomart Tech Park  
 99, 5<sup>th</sup> Cross, 5<sup>th</sup> Block, Koramangala  
 Bangalore – 560 095, Karnataka  
 India  
 Tel : +91 80 4111-7200

**Infomart Technologies**  
 Americas sales office  
 5904, South Cooper St. #104-96  
 Arlington, Texas, 76017, USA  
 Tel : +1 (682) 234-4600

**E-mail : pesales@infomartgroup.com**

Infomart® reserves the right to alter or improve the specification, internal design or manufacturing process at any time, without notice. Please check with your distributor or visit our website to ensure that you have the current and complete specification for your product before use. © Infomart Asia Pacific Pte. Ltd. All rights reserved. This publication, in full or in part, may not be copied, transmitted or stored in a retrieval system, or reproduced in any way including, but not limited to, magnetic, digital, photographic, photocopy, magnetic or other recording means, without prior written permission from Infomart Asia Pacific Pte. Ltd. Infomart is a registered trademark of Infomart® (India) Pvt. Ltd. PoweredEthernet™ is a trademark of Infomart (India) Pvt. Ltd.