

ASSEMBLY

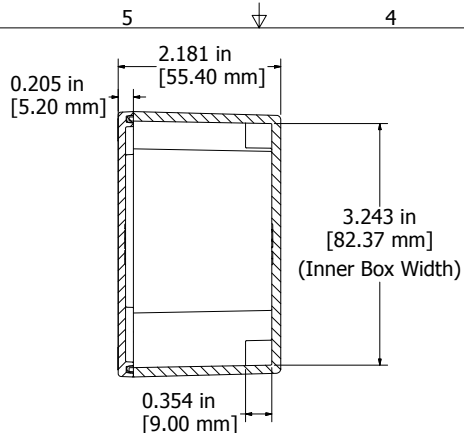

SECTION M-M
End View of Assembly

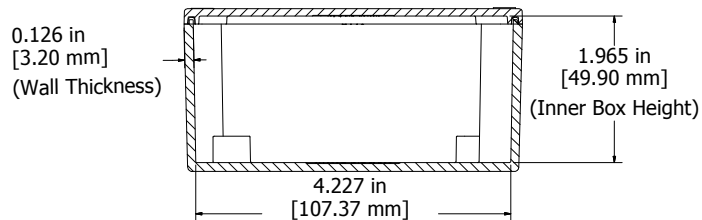

SECTION L-L
Side View of Assembly

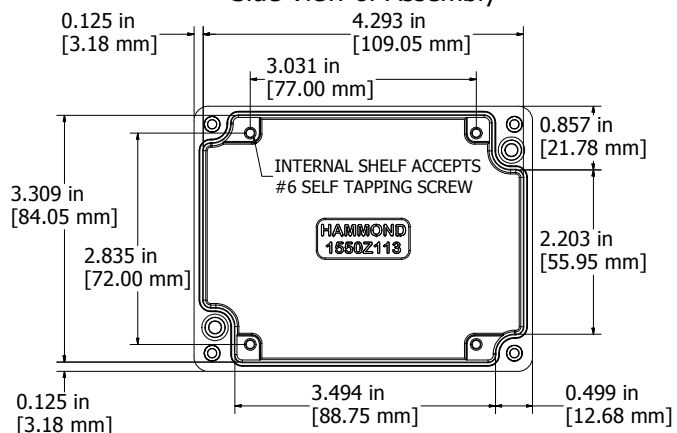

Top View Looking Inside Box

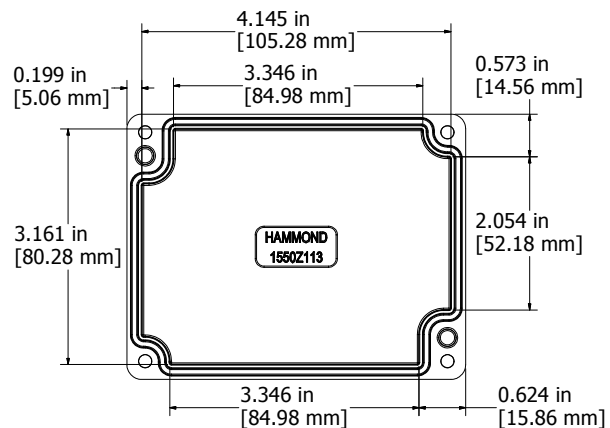

View Looking Inside Lid



UL US LISTED

File #E71073
NEMA 4, 4X

Enclosures can be Factory Modified (Milling, Drilling, Printing etc.)
Contact Factory mjm@hammondmfg.com for quotes
Solid models of this enclosure available in STEP or IGES.

NOTES

Purchased assembly includes enclosure, M4x20 lid screws and Pre-formed Silicone Gasket

Cover screws should be torqued to 5-7.5 lbf.in (50-75 cN.m)

1550Z113

PART NUMBERS

Natural Finish Enclosure	1550Z113
Black Textured Enclosure	1550Z113BK

HAMMOND MANUFACTURING™

1550Z113

www.hammondmfg.com