

# Test Procedure for the LV8136V Evaluation Board

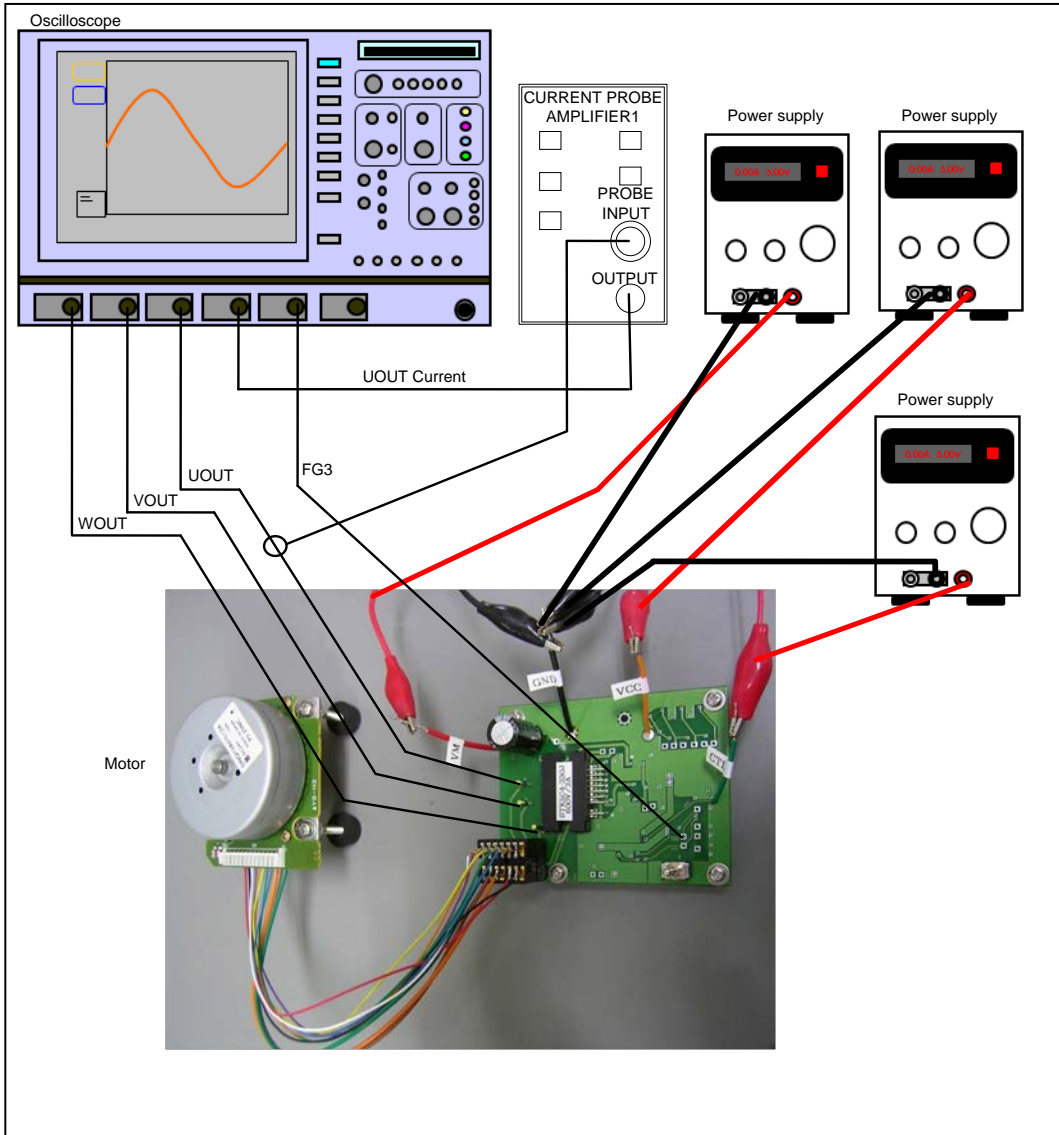

## Socket pin assignment for motor connection

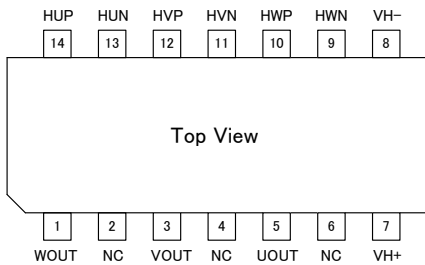

UOUT, VOUT, WOUT :Motor driver output  
 VH+, VH- :Hall IC Bias  
 HUP, HVP, HWP :Hall IC signal input

## Motor socket connection (for Hall IC input)

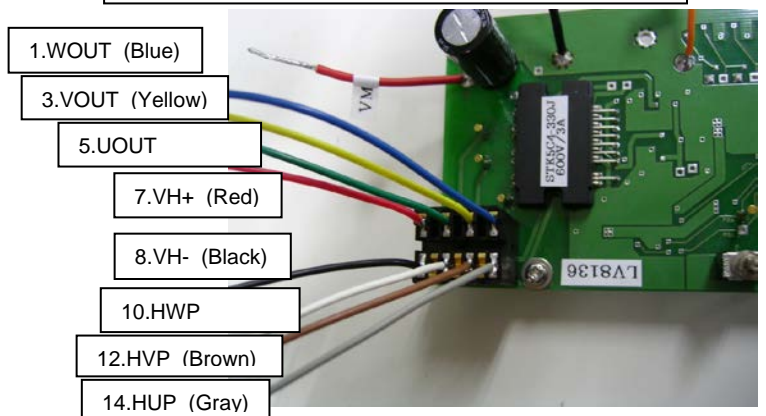

Table: Required Equipment

Equipment	Efficiency
Power supply	450V-3A
Power supply	18V-3A
Power supply	18V-3A
Oscilloscope	5 channel
Current probe	
LV8136V Evaluation Board	
Motor	

**Test Procedure:**

1. Connect the test setup as shown above.
2. Connect CTL power supply (0V to VCC) between CTL and GND. First, set to 0V.
3. Connect IC power supply (13.5V to 16.5V) between VCC and GND. First, set to 15V.
4. Connect motor power supply between VM and GND. First, set to 24V.
5. Please increase CTL voltage to 3V.
6. If the motor does not run, please increase VM voltage until the motor runs.
7. Please increase CTL voltage to 5.4V slowly.
8. If there is no problem at this point, please increase VM voltage to the rated voltage of the motor.  
(\*Maximum voltage of capacitor C20 is 450V. Please use the ones that are sufficient to withstand voltage VM.)

1. Initial check

Confirm that the motor rotates smoothly and is in the correct direction.

Check the waveforms.

Check the UOUT, VOUT, WOUT and 3FG voltage waveform at scope CH1, CH2, CH3 and CH5, and the output current waveform of UOUT at scope CH4 by the Oscilloscope.

ex) Waveforms can vary depend on usage motors.

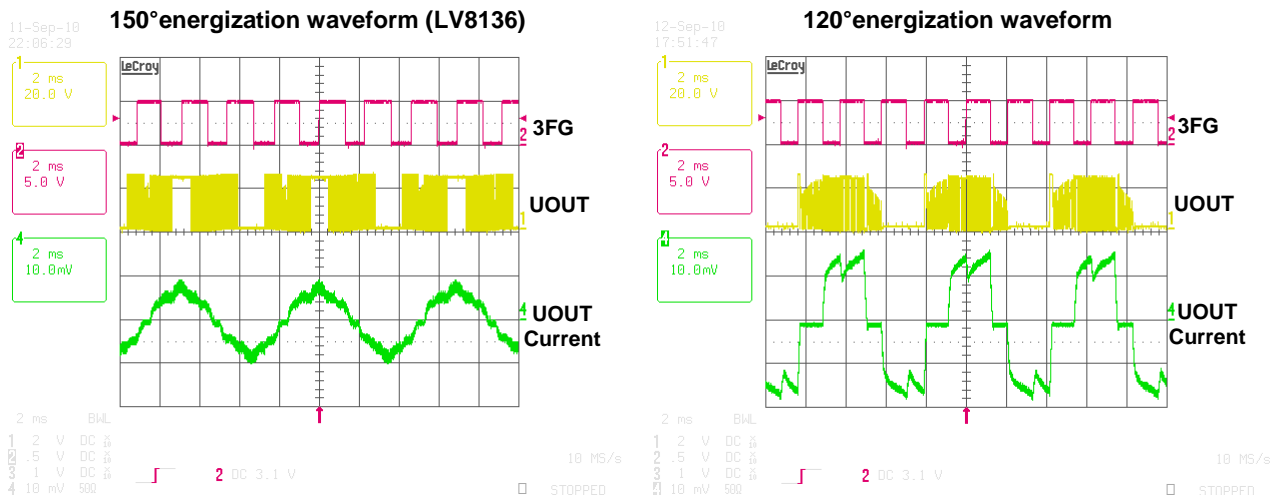

2. Speed control check

You can control rotation of the motor by changing the voltage of “CTL”(9PIN).

CTL input voltage ranges from 0 to VCC. Depends on voltage, a mode is switched into 4 types of modes: Power Saving Mode, Standby Mode, Drive Mode, and Test Mode.

(Drive Mode:  $2.1V \leq V_{CTL} \leq 5.4V$  (TYP))

\* Please refer to development specification for details of each mode.

- **Power Saving Mode** (0V to 1.0V) **Power consumption is zero.**
- **Standby Mode** (1.0V < CTL < 2.1) Standby state, yet ready for driving motor.

- **Drive Mode** (2.1V<CTL<5.4V) Output PWM DUTY is controllable from 0% to 90%.
- **Test Mode** (8V to VCC) 120° energization (Max Duty: fixed to 90%)

3. Forward/Reverse rotation check

“F/R”(18PIN) includes switch (SW) to select between VREG5/GND.

You can switch between forward/reverse.

\*Please do not use the switch while the motor is in rotation.

4. Lock detection check (Motor-Lock-mode)

Check the Lock detection behavior. (Lock)

At each VCC, stop the Motor manually by force.

After about 2 seconds, the motor will start rotation automatically.

5. Check result

Check table is as shown below.

VCC	Each waveforms	Speed control check	Forward/Reverse rotation check	Lock detection check		
16V	UOUT, UOUT current, 3FG OK?	the motor rotates smoothly at speed up/down	OK?	OK?		

A sample of checking result is shown below.

VCC	Each waveforms	Speed control check	Forward/Reverse rotation check	Lock detection check		
16V	UOUT, UOUT current, 3FG OK?	the motor rotates smoothly at speed up/down	OK?	OK?		