



PART NAME

PTQ SERIES ENCLOSURE

PART No.

PTQ-11050

PTQ-11050-C

REV. DATE

2-6-15

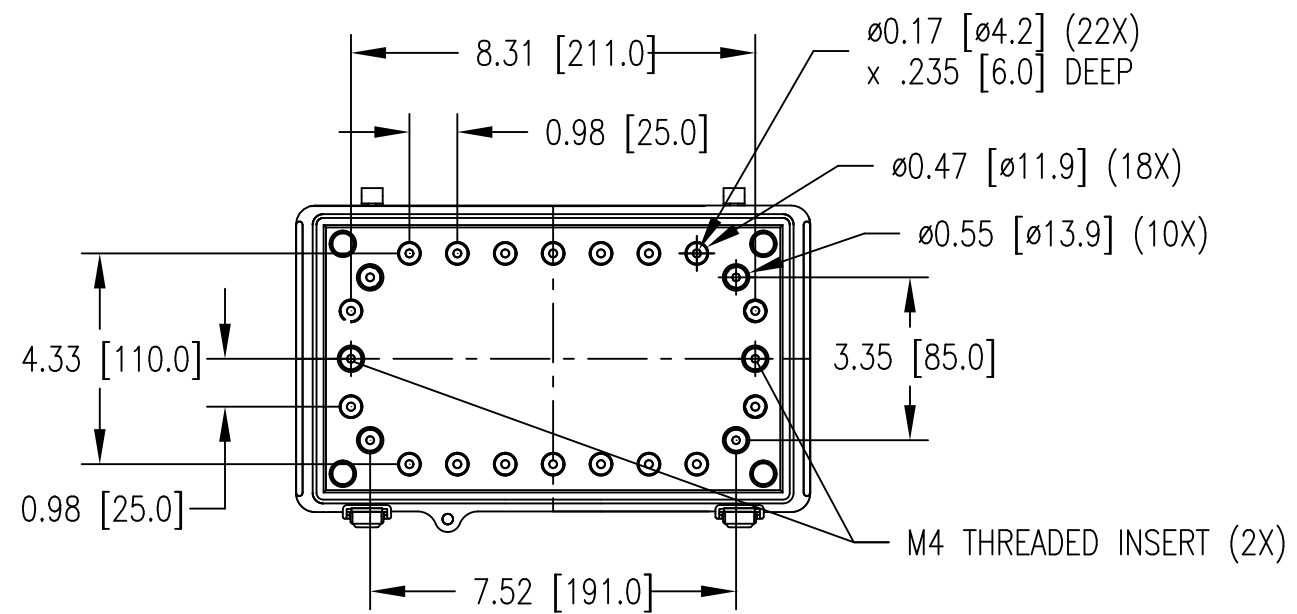
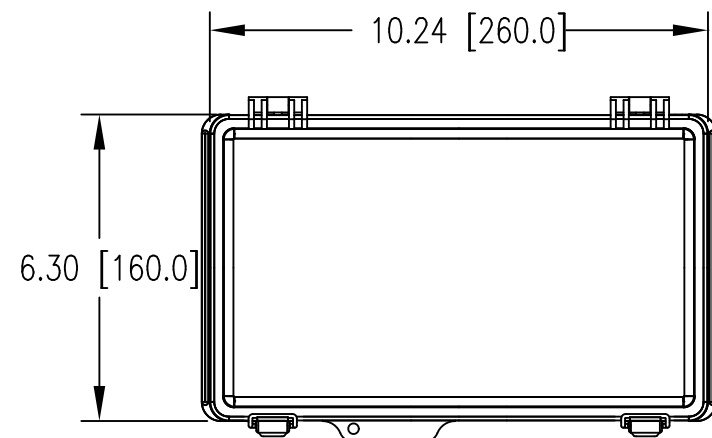

INSIDE VIEW OF BODY WITH COVER REMOVED

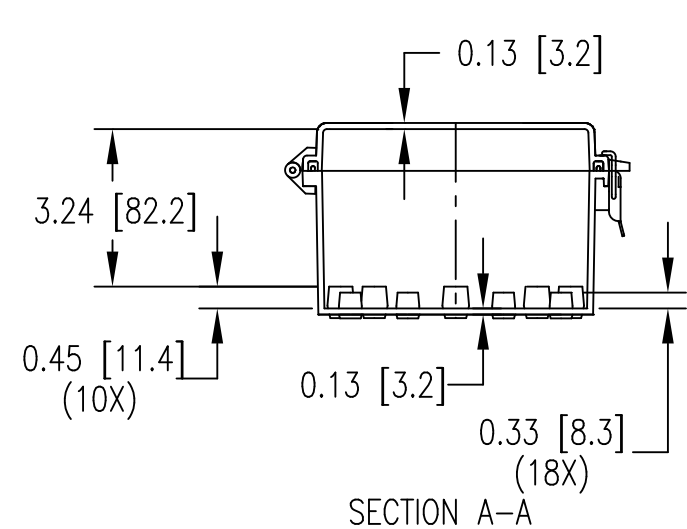

SECTION A-A

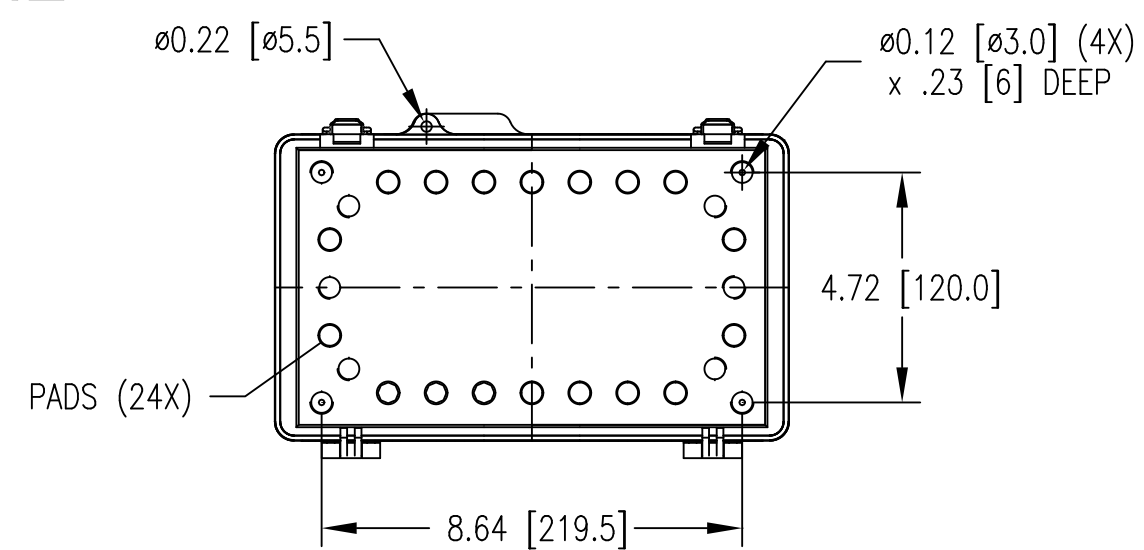
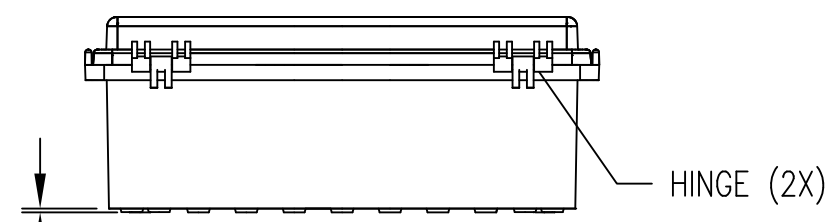
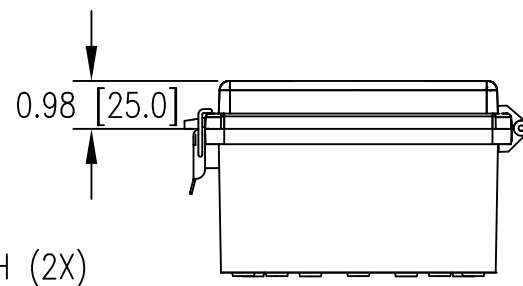
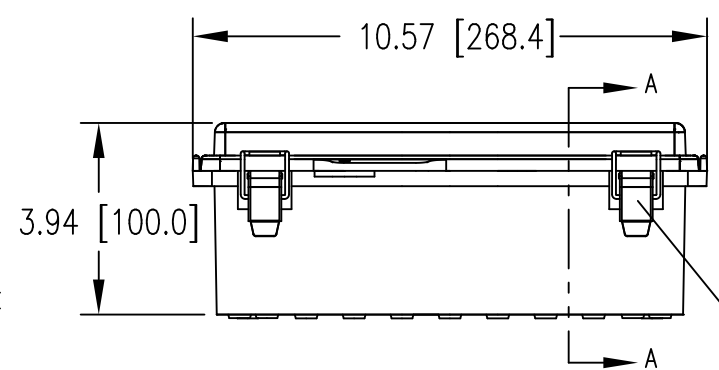

MATERIAL:

BODY - POLYCARBONATE RESIN 10% GLASS FIBER FILLED
COVER - POLYCARBONATE

COLOR:

BODY - LIGHT GRAY
COVER - LIGHT GRAY OR CLEAR (SUFFIX -C)

UL508 / NEMA TYPE 4X WITH IP-67 TUV RATING & UL-94 5VA RATING
CONTINUOUS GASKET IN COVER
SUPPLIED WITH TWO M4 x 8mm LG. TRUSS HEAD MACHINE SCREWS

DIMENSIONS ARE INCH [MM]
DRAWING FOR REFERENCE