

Radial lead Type

Series: **HZ**



■ Features

- Miniaturized, High withstand voltage
- Can be discharge mA or more current
- RoHS directive compliant

■ Recommended Applications

- Solar battery operated circuits
- Back-up Power Supplies (UPS)

■ Specifications

Category Temp. Range	-25 °C to +70 °C		
Maximum Operating Voltage	2.5 V.DC		
Nominal Cap. Range	3.3 F	4.7 F	10 F
Characteristics at Low Temperature	Capacitance change	±30 % of initial measured value at 20 °C (at -25 °C)	
	Internal resistance	≤4 times of initial specified value. (at -25 °C)	
Endurance	After 1000 hours application of 2.5 V at +70 °C		
	Capacitance change	±30 % of initial measured value at 20 °C	
	Internal resistance	≤4 times of initial specified value.	
Shelf Life	After 1000 hours storage at +70 °C without load (voltage)		
	Capacitance change	±30 % of initial measured value at 20 °C	
	Internal resistance	≤4 times of initial specified value.	

■ Dimensions in mm (not to scale)

(Unit : mm)

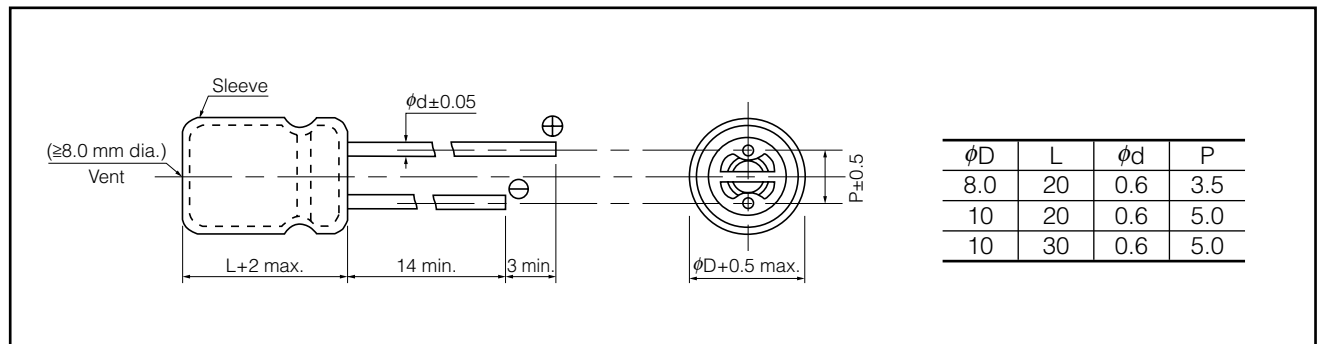

■ Standard Products

Category temp. range (°C)	Maximum operating voltage (V.DC)	Capacitance (F)	Capacitance tolerance (F)	Internal resistance (Initial specified value) (Ω) at 1 kHz	Recommended discharge current	Parts number	Mass (Reference value) (g)	Min. Packaging Q'ty (pcs)
-25 to +70	2.5	3.3	2.64 to 4.62	≤ 0.3	300 mA or less	EECHZ0E335	1.5	200
		4.7	3.76 to 6.58	≤ 0.3	300 mA or less	EECHZ0E475	2.1	200
		10	8 to 14	≤ 0.2	1 A or less	EECHZ0E106	3.1	200

Note : 1. Do not use reflow soldering. (IR, Atmosphere heating methods, etc.)
Please refer to the page of "Application Guidelines".

Design and specifications are each subject to change without notice. Ask factory for the current technical specifications before purchase and/or use.
Should a safety concern arise regarding this product, please be sure to contact us immediately.