

SERPAC RB22

Electronic Enclosures

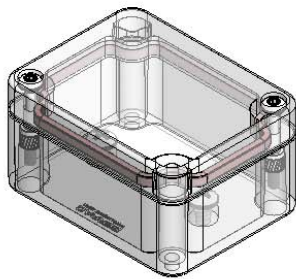

RB22-1TC1BC 2

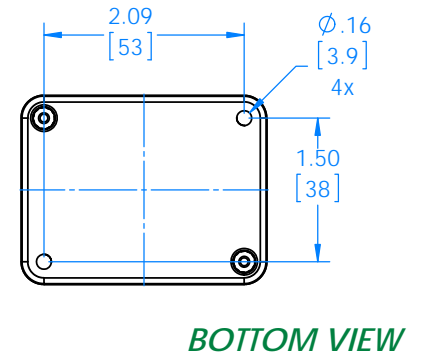
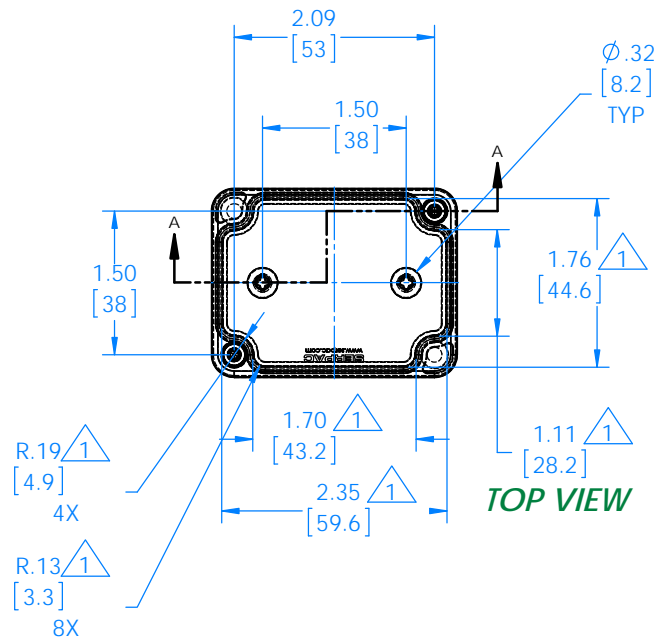
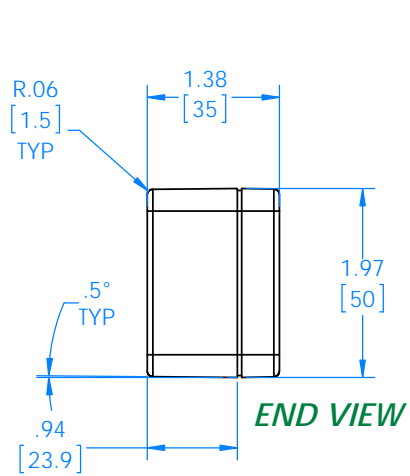
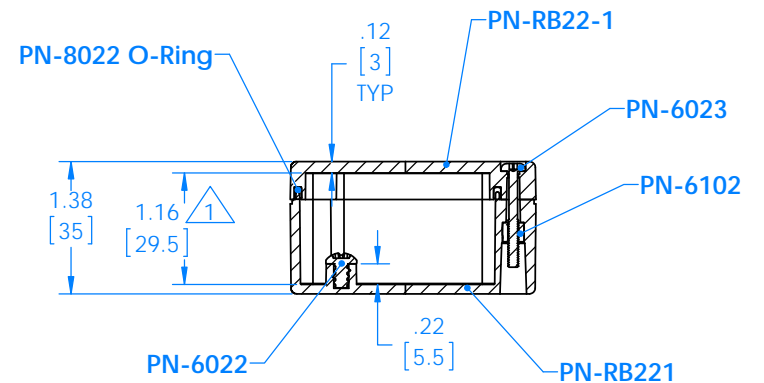
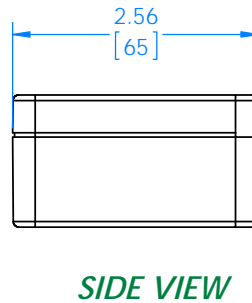

PN	Description
RB22-1	(1) RB22 Top1
RB221	(1) RB22 Bottom1
8022	(1) RB22 O-Ring
6023	(4) #4-40 Captive Torx Hd Screw
6022	(4) #10 High/Low Pan Hd x 1/4"
6102	(4) #4-40 Threaded Insert

- 1 =INTERIOR DIMENSIONS (@ BOTTOM)
- 2 =STANDARD COLORS ARE: BLACK, CLEAR AND GRAY
TOPS (T) AND BOTTOMS (B). ALL POSSIBLE COMBINATIONS

-Material: UV stabilized Polycarbonate
Flammability UL 94 V-0
-Watertight enclosure meets or
exceed Nema 4 and/or IP67.

Dim's in Inch
[mm]

SERPAC RB22 bottom board

Electronic Enclosures

