

# Card Guides

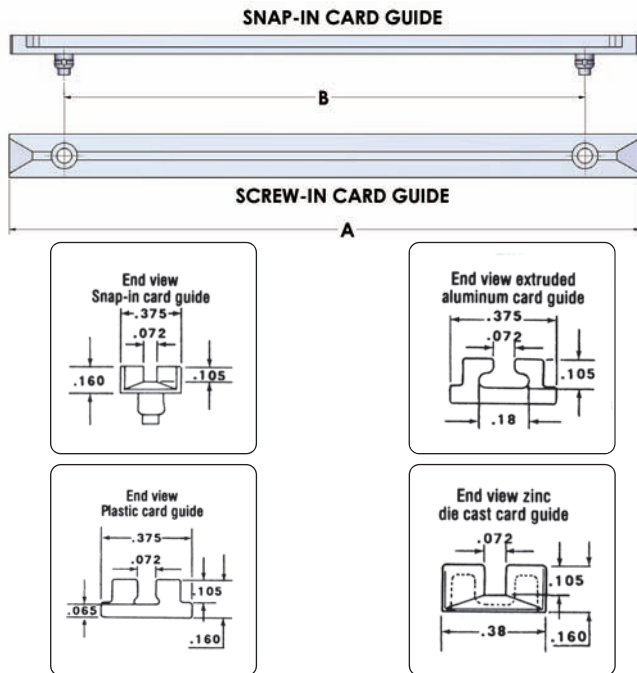

High quality card guides feature tapered slots for easy insertion. Snap-in nylon models provide easy installation and removal without tools, and can be positioned at 0.25" increments (64 0.156" holes on 0.250" centers) when used with Vector-Pak T-struts (TS169-6/90). Screw-mounted models (installation hardware included) are available in metal or plastic and provide variable positioning along entire length of strut. Holes for mounting guides to struts are based on center-to-center multiples of 0.75". All materials are flame retardant.

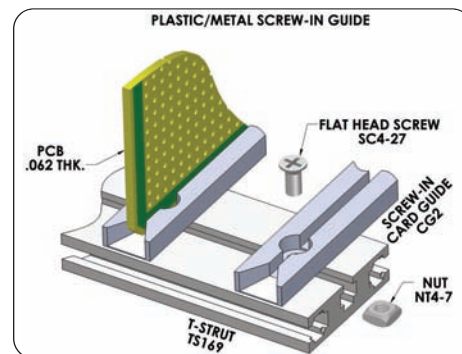

Metal or plastic screw down card guides attach with SC4-27/25 flat head screw and NT4-7PA square nut

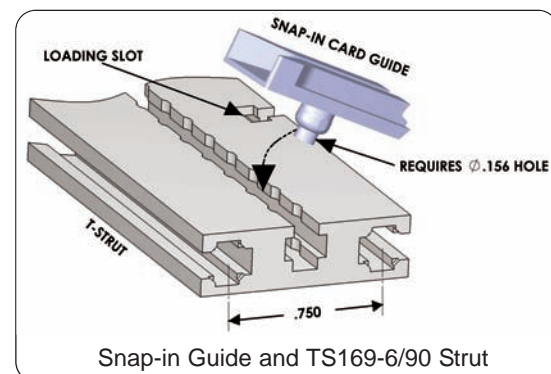

Part No.	Type	Length A	Centers B	Card Length	Application
CG2-45P	Plastic, Screw	2.89"	2.25"	4.50"	Subrack series 12, 13, 14, 17, 18 & 100 and Vector P series sidewalls
CG2-45S	Nylon, Snap-in	3.17"	2.25"	4.50"	
CG2-50P	Plastic, Screw	4.39"	3.75"	5.00"	
CG2-65M	Metal, Die Cast Screw	5.42"	4.50"	6.50"	
CG2-65P	Plastic, Screw	5.42"	4.50"	6.50"	
CG2-65S	Nylon, Snap-in	5.42"	4.50"	6.50"	Subrack series 14, 15, 17, 18 and 100 and Vector P series sidewalls ending in 119 or 156
CG2-80P	Plastic, Screw	6.64"	6.00"	8.00"	
CG2-80S	Nylon, Snap-in	6.93"	6.00"	8.00"	
CG2-95M	Metal, Screw	8.14"	7.50"	9.50"	
CG2-95P	Plastic, Screw	8.14"	7.50"	9.50"	
CG2-95S	Nylon, Snap-in	8.43"	7.50"	9.50"	CCA19
CG2-135M	Metal, Screw	13.19"	12.55"	13.50"	
CG2-135P	Plastic, Screw	13.19"	12.55"	13.50"	

Packages of 12 ea. Screw down types include installation hardware and are available in custom lengths on request.

## Free Standing Connector Mounted Card Guides

Secure connection, rugged support of 0.062" thick PCB's when space is limited. P/N BR27D is die cast of zinc alloy#3 (ASTM B240-06). Other sizes are 6063 T5 aluminum alloy. All sizes include HD55 hardware kit to attach connector to board. Connector not included (See Page 70). All sold as a pair and are fully RoHS compliant.

Part No.	Use With Connector	For Use With	Material
BR27D	R644, R644-2, R644-3C, R644-3F	4.5"W (3677, 3682 & 3662 series), Page 57	Zinc #3
BR27-1	R636-1, R636-2	4.5"W (3719 series), Page 58	Al Alloy 6063 T5
BR27-3	R630	2.73"W (3797 series), Page 56	Al Alloy 6063 T5
BR27-5	R656-1, R656-2	4.5"W (4610 series), Page 63	Al Alloy 6063 T5

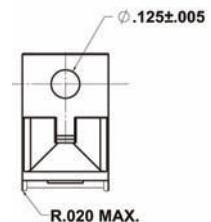
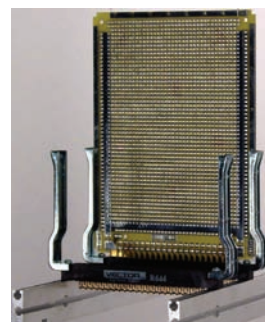

BR27D Zinc die-cast model shown

Details of BR27-1, -3 & -5 at [www.vectorelect.com](http://www.vectorelect.com)

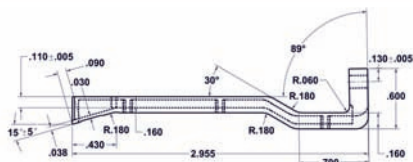

8 7 6 5 4 3 2 1

REVISIONS				
ZONE	REV.	DESCRIPTION	DATE	APPROVED
ALL	F		01/08/09	

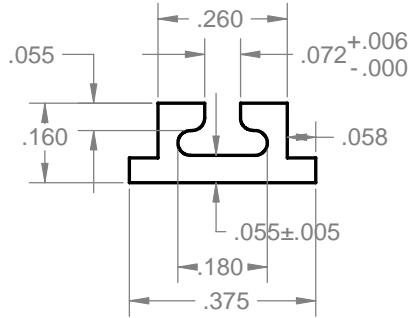

SECTION K-K  
SCALE 4:1

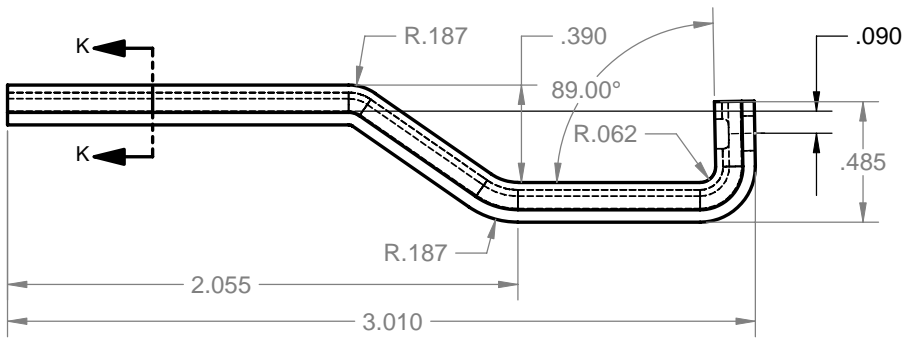
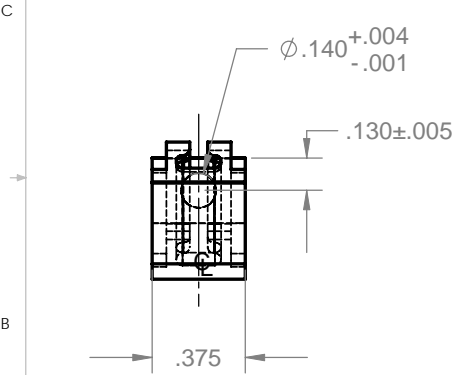
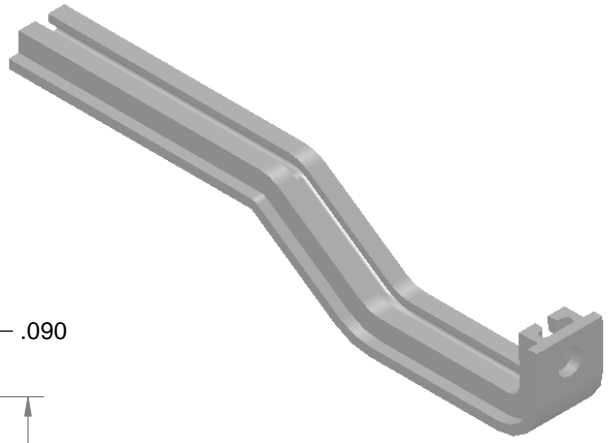
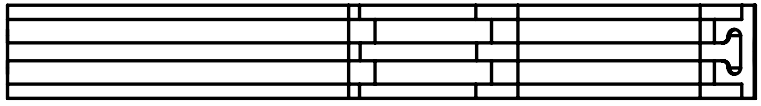

- 4. PARTS TO BE DEGREASED AFTER FABRICATION
- 3. PARTS TO BE FREE OF EXCESSIVE BURRS AND SURFACE SCRATCHES
- 2. FINISH: CLEAR ANODIZE
- 1. MATERIAL: ALUM. EXTRUSION 6063-T5

NOTES: UNLESS OTHERWISE SPECIFIED.

**PROPRIETARY AND CONFIDENTIAL**  
THE INFORMATION CONTAINED IN THIS DRAWING IS THE SOLE PROPERTY OF VECTOR ELECTRONICS & TECH., INC. ANY REPRODUCTION IN PART OR AS A WHOLE WITHOUT THE WRITTEN PERMISSION OF VECTOR ELECTRONICS & TECH., INC. IS PROHIBITED.

UNLESS OTHERWISE SPECIFIED:  
DIMENSIONS ARE IN INCHES  
TOLERANCES:  
FRACTIONAL ±  
ANGULAR: ±.5°  
TWO PLACE DECIMAL ±.03  
THREE PLACE DECIMAL ±.010  
INTERPRET GEOMETRIC TOLERANCING PER:  
MATERIAL **1**  
FINISH **2**  
DO NOT SCALE DRAWING

NAME	DATE
DRAWN TRUSHAR	01/08/09
CHECKED	
ENG APPR.	
MFG APPR.	
Q.A.	

**VECTOR** ELECTRONICS & TECHNOLOGY, INC. CA 91605  
11115 VANOWEN ST., NORTH HOLLYWOOD, CA 91605

**CARD GUIDE BR27-3**

SIZE DWG. NO. **B M5474-1-8** REV **F**

SCALE: 1:1 WEIGHT: SHEET 1 OF 1



8 7 6 5 4 3 2 1

8 7 6 5 4 3 2 1

REVISIONS				
ZONE	REV.	DESCRIPTION	DATE	APPROVED
ALL	F		01/08/09	

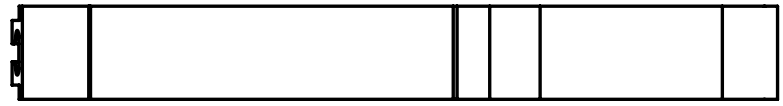
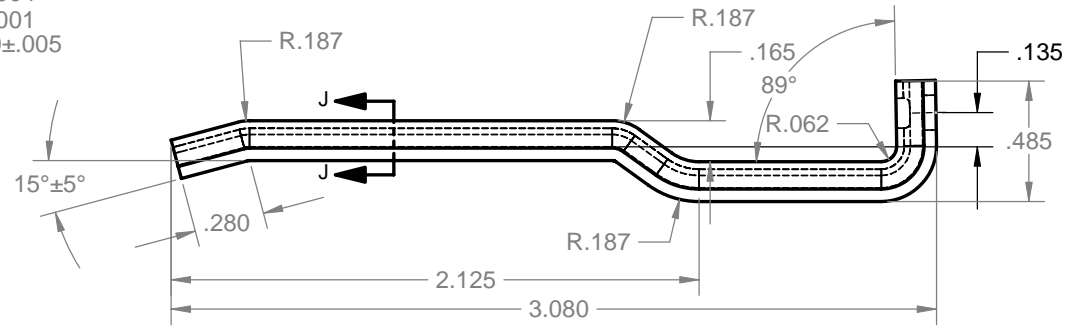
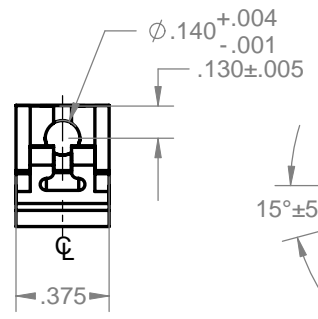
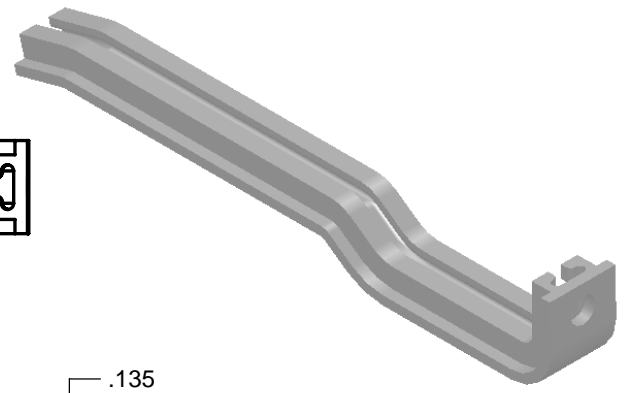
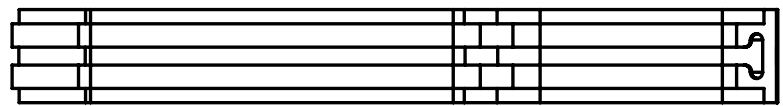
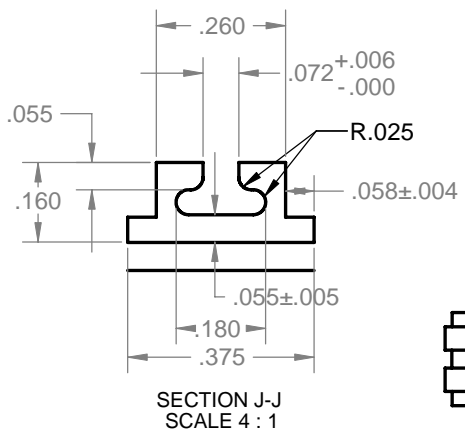

4. PARTS TO BE DEGREASED AFTER FABRICATION  
 3. PARTS TO BE FREE OF EXCESSIVE BURRS AND SURFACE SCRATCHES  
 2. FINISH: CLEAR ANODIZE  
 1. MATERIAL: ALUM. EXTRUSION 6063-T5
- NOTES: UNLESS OTHERWISE SPECIFIED.

**PROPRIETARY AND CONFIDENTIAL**  
 THE INFORMATION CONTAINED IN THIS DRAWING IS THE SOLE PROPERTY OF VECTOR ELECTRONICS & TECH., INC. ANY REPRODUCTION IN PART OR AS A WHOLE WITHOUT THE WRITTEN PERMISSION OF VECTOR ELECTRONICS & TECH., INC. IS PROHIBITED.

UNLESS OTHERWISE SPECIFIED:  
 DIMENSIONS ARE IN INCHES  
 TOLERANCES:  
 FRACTIONAL ±  
 ANGULAR: ±5°  
 TWO PLACE DECIMAL ±.03  
 THREE PLACE DECIMAL ±.010  
 INTERPRET GEOMETRIC TOLERANCING PER:  
 MATERIAL **1**  
 FINISH **2**  
 DO NOT SCALE DRAWING

NAME	DATE
DRAWN TRUSHAR	01/08/09
CHECKED	
ENG APPR.	
MFG APPR.	
Q.A.	

**VECTOR** ELECTRONICS & TECHNOLOGY, INC. 11115 VANOWEN ST., NORTH HOLLYWOOD, CA 91605

**CARD GUIDE BR27-1**

SIZE DWG. NO. **B M5474-1-5** REV **F**

SCALE: 1:1 WEIGHT: SHEET 1 OF 1



8 7 6 5 4 3 2 1

8 7 6 5 4 3 2 1

REVISIONS				
ZONE	REV.	DESCRIPTION	DATE	APPROVED
ALL	F		01/08/09	

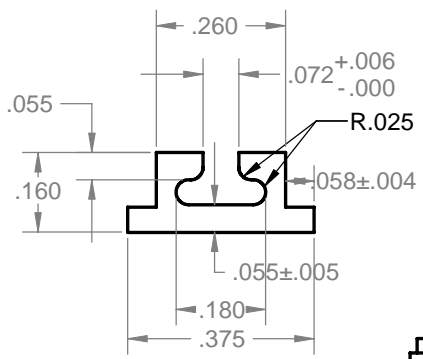

SECTION K-K  
SCALE 4 : 1

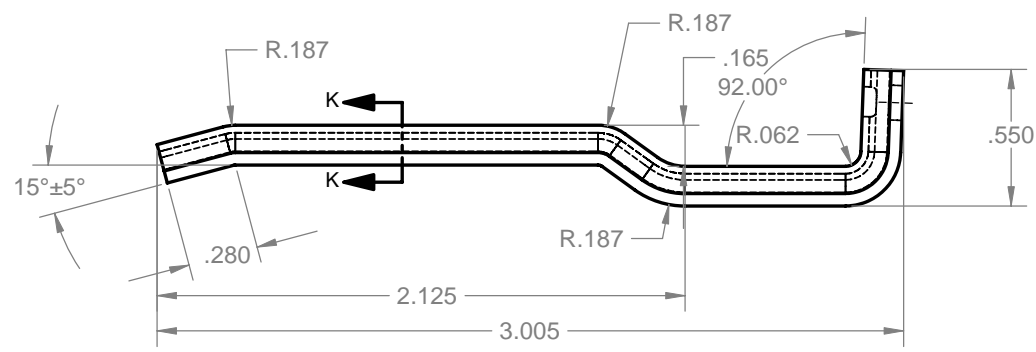
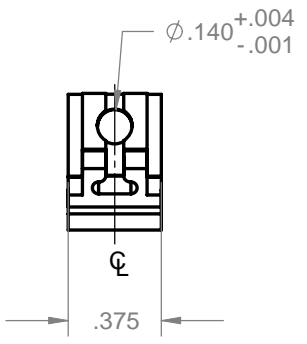
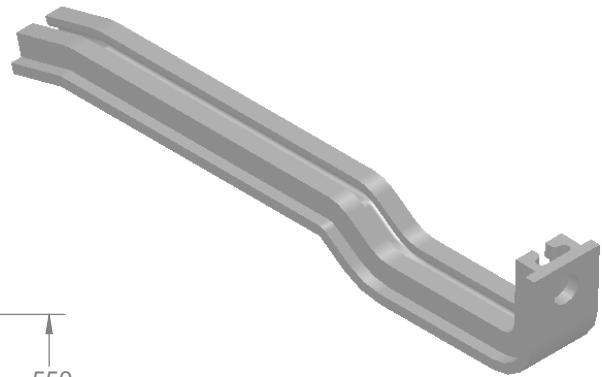

- 4. PARTS TO BE DECREASED AFTER FABRICATION
- 3. PARTS TO BE FREE OF EXCESSIVE BURRS AND SURFACE SCRATCHES
- 2. FINISH: CLEAR ANODIZE
- 1. MATERIAL: ALUM. EXTRUSION 6063-T5

NOTES: UNLESS OTHERWISE SPECIFIED.

**PROPRIETARY AND CONFIDENTIAL**  
THE INFORMATION CONTAINED IN THIS DRAWING IS THE SOLE PROPERTY OF VECTOR ELECTRONICS & TECH., INC. ANY REPRODUCTION IN PART OR AS A WHOLE WITHOUT THE WRITTEN PERMISSION OF VECTOR ELECTRONICS & TECH., INC. IS PROHIBITED.

UNLESS OTHERWISE SPECIFIED:  
DIMENSIONS ARE IN INCHES  
TOLERANCES:  
FRACTIONAL ±  
ANGULAR: ±5°  
TWO PLACE DECIMAL ±.03  
THREE PLACE DECIMAL ±.010  
INTERPRET GEOMETRIC TOLERANCING PER:  
MATERIAL **1**  
FINISH **2**  
DO NOT SCALE DRAWING

NAME	DATE
DRAWN TRUSHAR	01/08/09
CHECKED	
ENG APPR.	
MFG APPR.	
Q.A.	

**VECTOR** 11115 VANOWEN ST., NORTH HOLLYWOOD, CA 91605  
ELECTRONICS & TECHNOLOGY, INC.

**CARD GUIDE BR27-5**

SIZE DWG. NO. **B M5474-1-12** REV **F**

SCALE: 1:1 WEIGHT: SHEET 1 OF 1



8 7 6 5 4 3 2 1