

# S18-2 Sensors

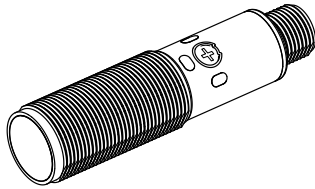

## Datasheet

Next Generation Self-Contained DC-Operated Sensors



- Economical photoelectric sensors for cost sensitive and high volume installations
- Powerful and bright visible red emitter beam for easy alignment and set-up
- Highly visible output and dual-function power and stability indicators
- Advanced ASIC technology is resistant to optical and electrical noise source
- Wide operating temperature range:  $-40\text{ }^{\circ}\text{C}$  to  $+70\text{ }^{\circ}\text{C}$  ( $-40\text{ }^{\circ}\text{F}$  to  $+158\text{ }^{\circ}\text{F}$ )
- Robust  $250^{\circ}$  adjustment potentiometer on select models



**WARNING: Not To Be Used for Personnel Protection**

Never use this device as a sensing device for personnel protection. Doing so could lead to serious injury or death. This device does not include the self-checking redundant circuitry necessary to allow its use in personnel safety applications. A sensor failure or malfunction can cause either an energized or de-energized sensor output condition.

## Models

Emitter/Receiver Models <sup>1</sup>			
Model Number		Range	Output
S18-2NAEL-2M	Emitter	25 m (82 ft)	None
S18-2NAEJ-2M		25 m (82 ft) with beam inhibit	
S18-2NAES-2M		25 m (82 ft) with adjustment	
S18-2VNRL-2M	Receiver	25 m (82 ft)	Complementary NPN
S18-2VPRL-2M			Complementary PNP
S18-2VNRS-2M		25 m (82 ft) with adjustment	Complementary NPN
S18-2VPRS-2M			Complementary PNP

Polarized Retroreflective Models <sup>1</sup>		
Model Number	Range	Output
S18-2VNLP-2M	6 m (19.7 ft) with BRT-84 reflector	Complementary NPN
S18-2VPLP-2M		Complementary PNP
S18-2VNLPC-2M	6 m (19.7 ft) with BRT-84 reflector, with adjustment	Complementary NPN
S18-2VPLPC-2M		Complementary PNP

Retroreflective Models <sup>1</sup>		
Model Number	Range	Output
S18-2VNLV-2M	7.5 m (24.6 ft) with BRT-84 reflector, with adjustment	Complementary NPN
S18-2VPLV-2M		Complementary PNP

<sup>1</sup> Only 2 m (6.5 ft) PVC cable models are listed. To order 9 m (30 ft) PVC cable models, add suffix "9M" (for example, S18-2VNDL-9M). To order 4-pin Euro M12 integral QD models, add suffix "Q8" (for example, S18-2VNDL-Q8). To order 4-pin Euro M12 pigtail QD models, add suffix "Q5" (for example, S18-2VNDL-Q5). To order 4-pin Pico M8 pigtail QD models, add suffix "Q3" (for example, S18-VNDL-Q3).



Diffuse Models <sup>1</sup>		
Model Number	Range	Output
S18-2VNDL-2M	750 mm (29.5 in) with adjustment	Complementary NPN
S18-2VPDL-2M		Complementary PNP
S18-2VNDS-2M	300 mm (11.8 in) with adjustment	Complementary NPN
S18-2VPDS-2M		Complementary PNP

## Installing the S18-2 Sensor

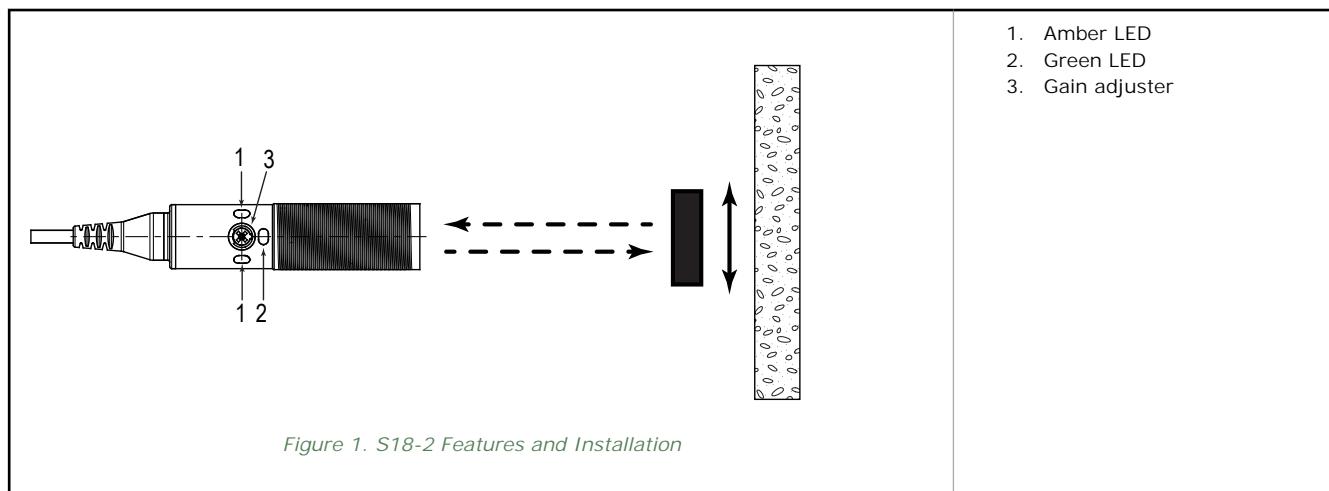

To install the S18-2 Sensor:

1. Align the sensor as required for the application. For the most sensitive object detection, align the sensor so that the objects move across the sensor's axis.
2. Secure the sensor to a bracket.
3. Adjust the gain adjuster (sensitivity pot) if necessary.
4. Wire sensor as shown in the wiring diagrams.

## Wiring Diagrams



NOTE: Open lead wires must be connected to a terminal block.

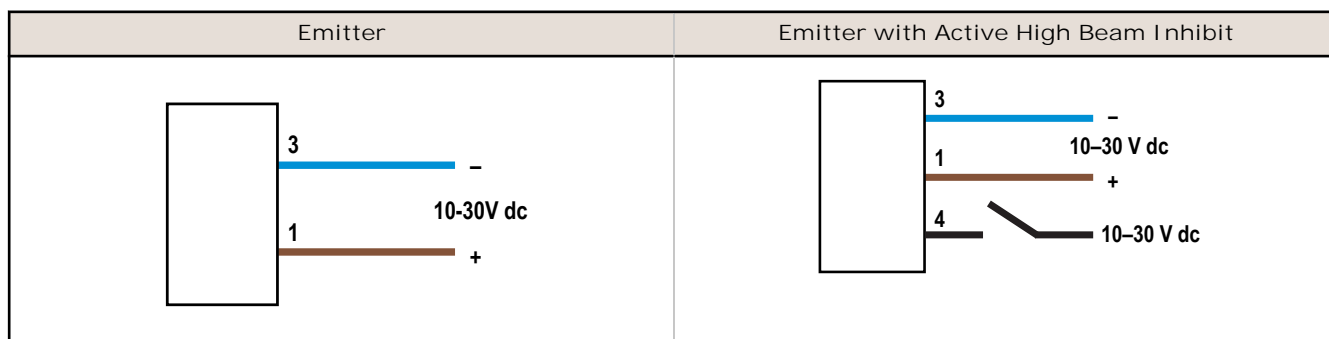

Complementary Current Sinking (NPN)		Complementary Current Sourcing (PNP)	
4-Pin Euro	4-Pin Pico	Key	
		1 = Brown 2 = White 3 = Blue 4 = Black	

## Specifications

### Supply Voltage

- 10 to 30 V dc for ambient temperature  $\leq 55\text{ }^{\circ}\text{C}$
- 10 to 24 V dc for ambient temperature  $> 55\text{ }^{\circ}\text{C}$

### Supply Current (Exclusive of Load Current)

- Diffuse: 16 mA
- Opposed Mode Emitters: 17 mA
- Opposed Mode Receivers: 8 mA
- Retroreflective and Polarized Retroreflective: 16 mA

### Supply Protection Circuitry

- Protected against reverse polarity and transient voltages

### Output Rating

- $\leq 50\text{ mA}$  total current for ambient temperatures  $> 55\text{ }^{\circ}\text{C}$
- $\leq 100\text{ mA}$  total current through both outputs  $\leq 55\text{ }^{\circ}\text{C}$
- OFF-State Leakage Current:  $< 50\text{ }\mu\text{A}$  at 30 V dc
- ON-State Saturation Voltage:  $< 1.5\text{ V}$  at 10 mA;  $< 3.0\text{ V}$  at 100 mA

### Output Configuration

- Complementary PNP or NPN by model number

### Environmental Rating

- IEC 60529 IEC IP67

### Vibration and Mechanical Shock

- All models meet Mil. Std. 202F requirements. Method 201A (Vibration; frequency 10 to 60 Hz, max., double amplitude 0.06 in acceleration 10G). Method 213B conditions H&I (Shock: 75G with unit operating; 100G for non-operation)

### Indicators

- Three LEDs (1 green, 2 amber)
- Green solid: indicates power applied and sensor ready
- Green flashing: indicates marginal sensing signal
- Amber solid: indicates Pin 4 (black wire) output conducting

### Adjustments

- Diffuse (DL, DS), Emitter (ES), Receiver (RS), Polarized Retroreflective (LPC), Retroreflective (LV) models: Single turn sensitivity (gain) adjustment potentiometer
- Emitter Beam Inhibit (EJ) models: Tie black wire to 10 to 30 V dc for beam inhibit

### Construction

- Housing, connector, gain pot driver: ABS; Front Window: PMMA; Indicator Windows: Clear ABS; Cable: PVC jacket; Pigtail QD: Nickel-plated brass and PVC jacket; Mounting Nuts: 30% glass filled PBT

### Output Protection Circuitry

- Protected against false pulse on power-up and continuous short circuit of outputs. Short circuit protection at elevated temperature may require a power cycle to reset.

### Emitter LED Wavelength

- All models: 624 nm

### Output Response Time

- Response is independent of signal strength
- Opposed mode: 1.5 milliseconds ON, 1.0 milliseconds OFF
- Retro, Polarized Retro, and Diffuse: 1.5 milliseconds ON, 0.75 milliseconds OFF
- Delay on Power-up: 100 milliseconds; outputs do not conduct during this time

### Repeatability

- Repeatability is independent of signal strength
- Opposed mode: 170 microseconds
- Retro, Polarized Retro, and Diffuse modes: 100 microseconds

### Operating Conditions

- Temperature:  $-40\text{ }^{\circ}\text{C}$  to  $+70\text{ }^{\circ}\text{C}$  ( $-40\text{ }^{\circ}\text{F}$  to  $+158\text{ }^{\circ}\text{F}$ )
- 95% at  $+50\text{ }^{\circ}\text{C}$  maximum relative humidity (non-condensing)

### Certifications



Ind. Cont. Eq.  
3TJJ

## Performance Curves

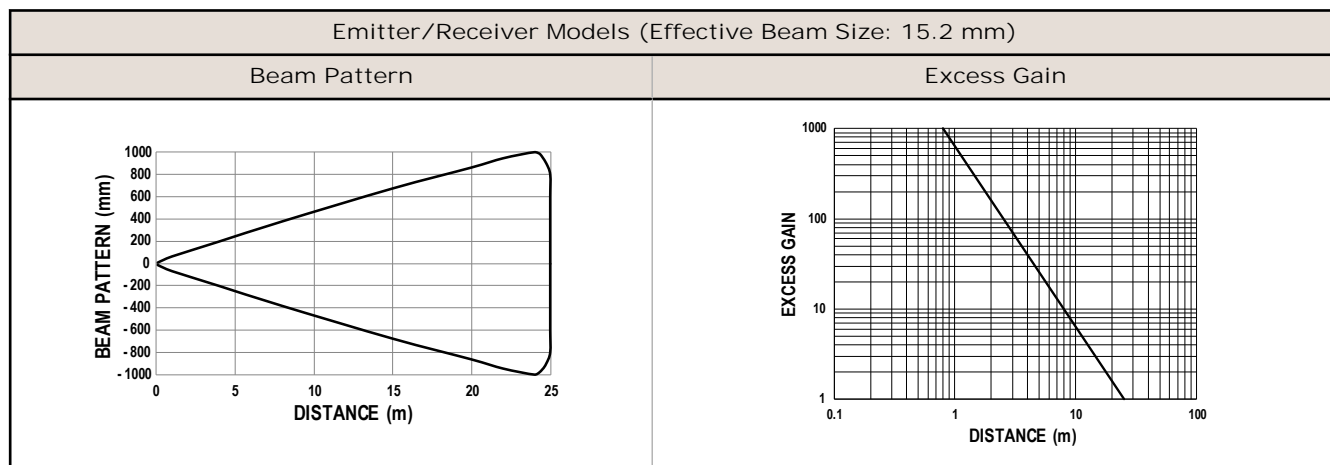
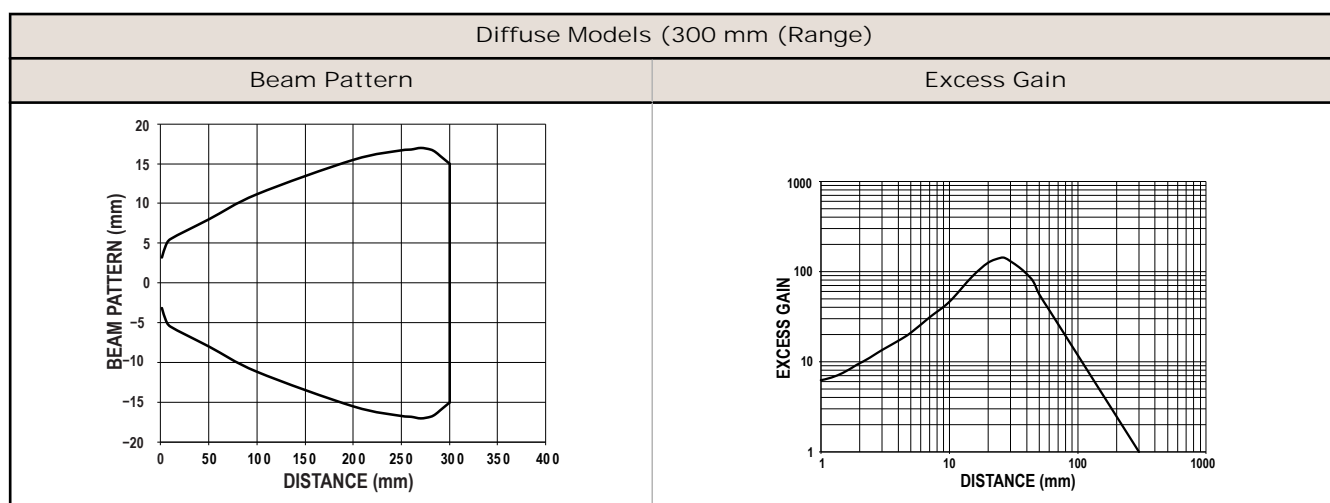
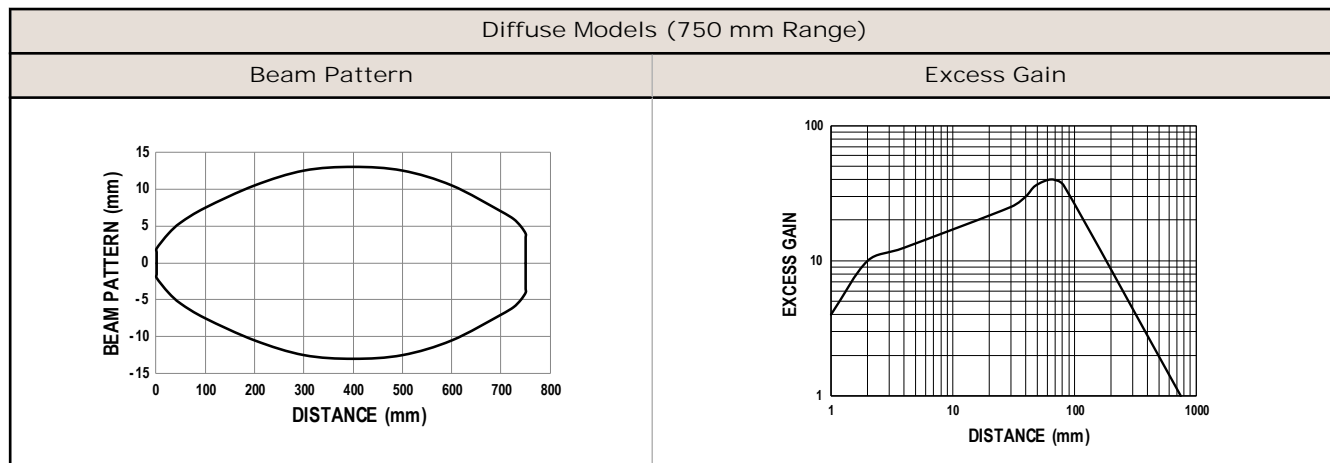

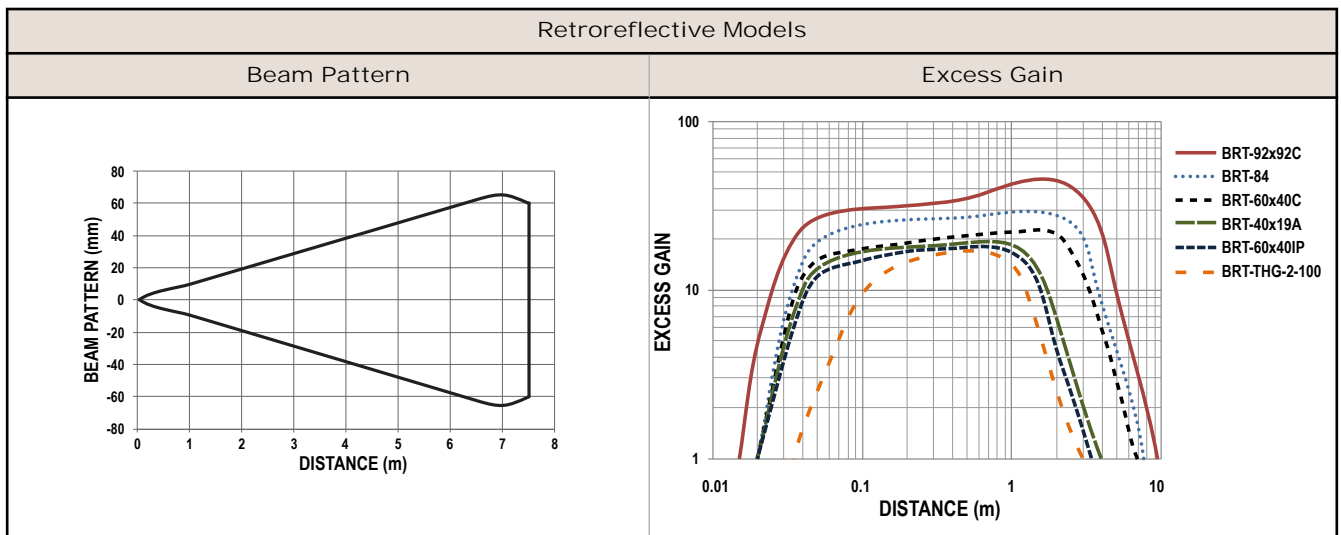
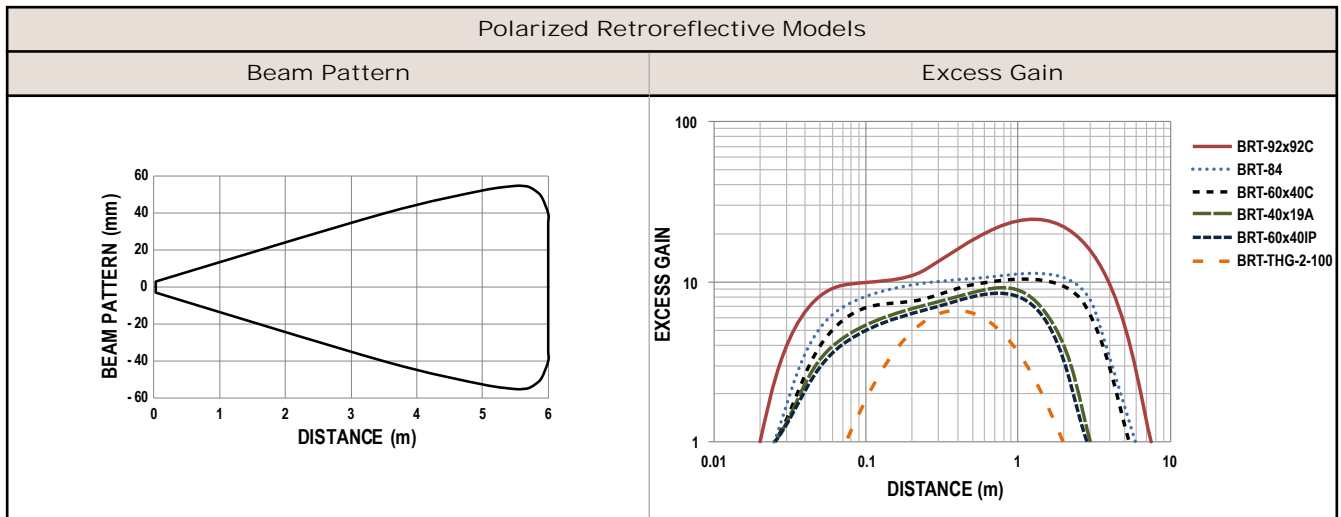

## Dimensions

All measurements are listed in millimeters (inches), unless noted otherwise.

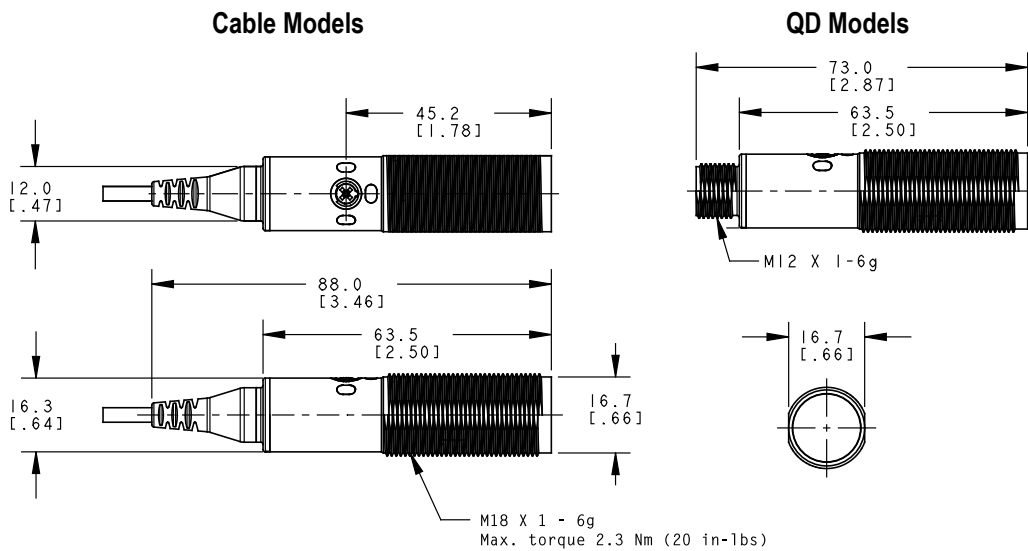

## Accessories

### Cordsets

4-Pin Threaded M12/Euro-Style Cordsets				
Model	Length	Style	Dimensions	Pinout (Female)
MQDC-406	1.83 m (6 ft)	Straight		<p>1 = Brown 2 = White 3 = Blue 4 = Black</p>
MQDC-415	4.57 m (15 ft)			
MQDC-430	9.14 m (30 ft)			
MQDC-450	15.2 m (50 ft)			
MQDC-406RA	1.83 m (6 ft)	Right-Angle		
MQDC-415RA	4.57 m (15 ft)			
MQDC-430RA	9.14 m (30 ft)			
MQDC-450RA	15.2 m (50 ft)			

4-Pin Threaded M8/Pico-Style Cordsets				
Model	Length	Style	Dimensions	Pinout (Female)
PKG4M-2	2 m (6.56 ft)	Straight		<p>1 = Brown 2 = White 3 = Blue 4 = Black</p>
PKG4M-5	5 m (16.4 ft)			
PKG4M-9	9 m (29.5 ft)			
PKW4M-2	2 m (6.56 ft)	Right Angle		
PKW4M-5	5 m (16.4 ft)			
PKW4M-9	9 m (29.5 ft)			

### Apertures

Model	Units	Aperture Description	Product
AP18SCN	3	Kit includes round apertures of 0.5 mm (0.02 in), 1.0 mm (0.04 in), and 2.5 mm (0.10 in) diameter.	
AP18SRN	3	Kit includes round apertures of 0.5 mm (0.02 in), 1.0 mm (0.04 in), and 2.5 mm (0.10 in) diameter. Kits include Teflon® FEP® lens, o-ring and thread-on housing.	
APG18S	1	Kit with glass lens to protect plastic sensor lens from chemical environments and weld splatter damage.	

## Brackets

For additional brackets, check the current Banner catalog or visit [www.bannerengineering.com](http://www.bannerengineering.com). All measurements are listed in millimeters, unless noted otherwise.

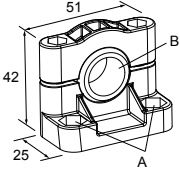
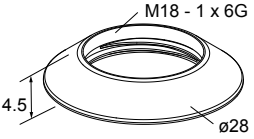
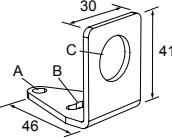
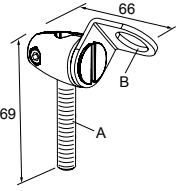
<p><b>SMB18SF</b></p> <ul style="list-style-type: none"> <li>• 18 mm swivel bracket with M18 x 1 internal thread</li> <li>• Black thermoplastic polyester</li> <li>• Stainless steel swivel locking hardware included</li> </ul>  <p>Hole center spacing: A = 36.0 Hole size: A = <math>\varnothing</math> 5.3, B = <math>\varnothing</math> 18.0</p>	<p><b>SMBS18-2-1</b></p> <ul style="list-style-type: none"> <li>• 30% glass-filled PBT</li> </ul> 								
<p><b>SMB18A</b></p> <ul style="list-style-type: none"> <li>• Right-angle mounting bracket with a curved slot for versatile orientation</li> <li>• 12-ga. stainless steel</li> <li>• 18 mm sensor mounting hole</li> <li>• Clearance for M4 (#8) hardware</li> </ul>  <p>Hole center spacing: A to B = 24.2 Hole size: A = <math>\varnothing</math> 4.6, B = 17.0 x 4.6, C = <math>\varnothing</math> 18.5</p>	<p><b>SMB18FA..</b></p> <ul style="list-style-type: none"> <li>• Swivel bracket with tilt and pan movement for precision adjustment</li> <li>• Easy sensor mounting to extruded rail T-slots</li> <li>• Metric and inch size bolts available</li> <li>• 18 mm sensor mounting hole</li> </ul>  <p>Hole size: B=<math>\varnothing</math> 18.1</p> <table border="1" data-bbox="824 1012 1448 1222"> <thead> <tr> <th>Model</th> <th>Bolt Thread (A)</th> </tr> </thead> <tbody> <tr> <td>SMB18FA</td> <td>3/8 - 16 x 2 in</td> </tr> <tr> <td>SMB18FAM10</td> <td>M10 - 1.5 x 50</td> </tr> <tr> <td>SMB18FAM12</td> <td>n/a; no bolt included. Mounts directly to 12 mm (1/2 in) rods</td> </tr> </tbody> </table>	Model	Bolt Thread (A)	SMB18FA	3/8 - 16 x 2 in	SMB18FAM10	M10 - 1.5 x 50	SMB18FAM12	n/a; no bolt included. Mounts directly to 12 mm (1/2 in) rods
Model	Bolt Thread (A)								
SMB18FA	3/8 - 16 x 2 in								
SMB18FAM10	M10 - 1.5 x 50								
SMB18FAM12	n/a; no bolt included. Mounts directly to 12 mm (1/2 in) rods								

## Reflectors

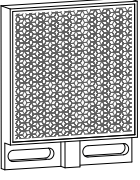
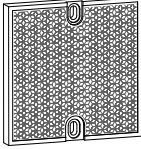
<p><b>BRT-2X2</b></p> <ul style="list-style-type: none"> <li>• Square, acrylic target</li> <li>• Reflectivity factor: 1.0</li> <li>• Max. temperature: +50 °C (+122 °F)</li> <li>• Optional brackets are available</li> <li>• Approximate size: 51 mm x 51 mm</li> </ul> 	<p><b>BRT-84X84A</b></p> <ul style="list-style-type: none"> <li>• Square, acrylic target</li> <li>• Reflectivity Factor: 2.0</li> <li>• Temperature: -20 °C to +60 °C (-4 °F to +140 °F)</li> <li>• Approximate size: 84 mm x 84 mm</li> </ul> 
--	--

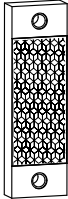
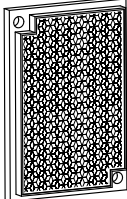
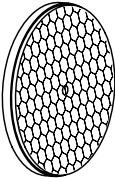
<p><b>BRT-40X19A</b></p> <ul style="list-style-type: none"> <li>• Rectangular, acrylic target</li> <li>• Reflectivity Factor: 1.3</li> <li>• Temperature: <math>-20\text{ }^{\circ}\text{C}</math> to <math>+60\text{ }^{\circ}\text{C}</math> (<math>-4\text{ }^{\circ}\text{F}</math> to <math>+140\text{ }^{\circ}\text{F}</math>)</li> <li>• Approximate size: 19 mm <math>\times</math> 60 mm overall; 19 mm <math>\times</math> 40 mm reflector</li> </ul>	 <p><b>BRT-60X40C</b></p> <ul style="list-style-type: none"> <li>• Rectangular, acrylic target</li> <li>• Reflectivity Factor: 1.4</li> <li>• Temperature: <math>-20\text{ }^{\circ}\text{C}</math> to <math>+60\text{ }^{\circ}\text{C}</math> (<math>-4\text{ }^{\circ}\text{F}</math> to <math>+140\text{ }^{\circ}\text{F}</math>)</li> <li>• Optional brackets are available</li> <li>• Approximate size: 40 mm <math>\times</math> 60 mm</li> </ul> 								
<p><b>BRT-84</b></p> <ul style="list-style-type: none"> <li>• Round, acrylic target</li> <li>• Reflectivity Factor: 1.4</li> <li>• Temperature: <math>-20\text{ }^{\circ}\text{C}</math> to <math>+60\text{ }^{\circ}\text{C}</math> (<math>-4\text{ }^{\circ}\text{F}</math> to <math>+140\text{ }^{\circ}\text{F}</math>)</li> <li>• Optional brackets are available</li> <li>• Approximate size: 84 mm diameter</li> <li>• Mounting Hole: 4.5 mm diameter</li> </ul> 	<p><b>Retroreflective Tape</b></p> <table border="1"> <thead> <tr> <th>Model</th> <th>Reflectivity Factor</th> <th>Maximum Temperature</th> <th>Size</th> </tr> </thead> <tbody> <tr> <td>BRT-THG-2-100</td> <td>0.7</td> <td><math>+60\text{ }^{\circ}\text{C}</math> (<math>+140\text{ }^{\circ}\text{F}</math>)</td> <td>50 mm (2 in) wide, 2.5 m (100 in) long</td> </tr> </tbody> </table>	Model	Reflectivity Factor	Maximum Temperature	Size	BRT-THG-2-100	0.7	$+60\text{ }^{\circ}\text{C}$ ( $+140\text{ }^{\circ}\text{F}$ )	50 mm (2 in) wide, 2.5 m (100 in) long
Model	Reflectivity Factor	Maximum Temperature	Size						
BRT-THG-2-100	0.7	$+60\text{ }^{\circ}\text{C}$ ( $+140\text{ }^{\circ}\text{F}$ )	50 mm (2 in) wide, 2.5 m (100 in) long						

## Banner Engineering Corp Limited Warranty

Banner Engineering Corp. warrants its products to be free from defects in material and workmanship for one year following the date of shipment. Banner Engineering Corp. will repair or replace, free of charge, any product of its manufacture which, at the time it is returned to the factory, is found to have been defective during the warranty period. This warranty does not cover damage or liability for misuse, abuse, or the improper application or installation of the Banner product.

THIS LIMITED WARRANTY IS EXCLUSIVE AND IN LIEU OF ALL OTHER WARRANTIES WHETHER EXPRESS OR IMPLIED (INCLUDING, WITHOUT LIMITATION, ANY WARRANTY OF MERCHANTABILITY OR FITNESS FOR A PARTICULAR PURPOSE), AND WHETHER ARISING UNDER COURSE OF PERFORMANCE, COURSE OF DEALING OR TRADE USAGE.

This Warranty is exclusive and limited to repair or, at the discretion of Banner Engineering Corp., replacement. IN NO EVENT SHALL BANNER ENGINEERING CORP. BE LIABLE TO BUYER OR ANY OTHER PERSON OR ENTITY FOR ANY EXTRA COSTS, EXPENSES, LOSSES, LOSS OF PROFITS, OR ANY INCIDENTAL, CONSEQUENTIAL OR SPECIAL DAMAGES RESULTING FROM ANY PRODUCT DEFECT OR FROM THE USE OR INABILITY TO USE THE PRODUCT, WHETHER ARISING IN CONTRACT OR WARRANTY, STATUTE, TORT, STRICT LIABILITY, NEGLIGENCE, OR OTHERWISE.

Banner Engineering Corp. reserves the right to change, modify or improve the design of the product without assuming any obligations or liabilities relating to any product previously manufactured by Banner Engineering Corp.