

San Ace C225 9TS type Centrifugal Fan

Features

High Airflow and Static Pressure

- Maximum airflow: 28.1 m³/min*¹
- Maximum static pressure: 861 Pa*¹
- High cooling performance even in equipment with high system impedance

Low Noise and Energy Efficiency

- Sound pressure level: 70.5 dB(A)*²
- Power consumption: 99.8 W*²
- Maintains high airflow and static pressure while limiting noise and power consumption.

*1: Specification of Model No. 9TS48P0G001

*2: Specification of Model No. 9TS48P0H001



φ225 mm × 99 mm

Specifications

The following nos. have **PWM controls, pulse sensors.**

Model No.	Rated voltage [V]	Operating voltage range [V]	PWM duty cycle (Note 1, 2) [%]	Rated current [A]	Rated input [W]	Rated speed [min ⁻¹]	Max. Airflow [m ³ /min] [CFM]	Max. Static pressure [Pa] [inchH ₂ O]	SPL [dB(A)]	Operating temperature [°C]	Expected life [h]
9TS48P0G001	48	36 to 72	100	3.65	175.2	3,550	28.1 992	861 3.46	74.5	-20 to +60	40,000
			15	0.24	11.5	1,000	7.85 277	68.5 0.28	52.0		
9TS48P0H001			100	2.08	99.8	2,900	22.7 801	590 2.37	70.5	-20 to +70	
			15	0.24	11.5	1,000	7.85 277	68.5 0.28	52.0		

Note 1: PWM frequency: 25 kHz

Note 2: Fans do not rotate when PWM duty cycle is 0%.

Note 3: When inlet nozzle [Option (Model: 109-1134)] is mounted.

Note 4: Max input is 380 W at rated voltage.

Available options: **Without Sensor**

Common Specifications

- Material Motor case: Aluminum, Impeller: Plastics (Flammability: UL94V-0)
- Expected life Refer to specifications
(L10: Survival rate: 90% at 60 °C, rated voltage, and continuously run in a free air state)
- Motor protection system Current blocking function and reverse polarity protection
- Dielectric strength 50 / 60 Hz, 500 VAC, 1 minute (between lead conductor and frame)
- Sound pressure level (SPL) Expressed as the value at 1 m from air inlet side
- Operating temperature Refer to specifications (Non-condensing)
- Storage temperature -30 °C to +70 °C (Non-condensing)
- Lead wire ⊕Red ⊖Black Sensor: Yellow Control: Brown
- Mass Approx. 1,220 g

Airflow - Static Pressure Characteristics

- PWM duty cycle

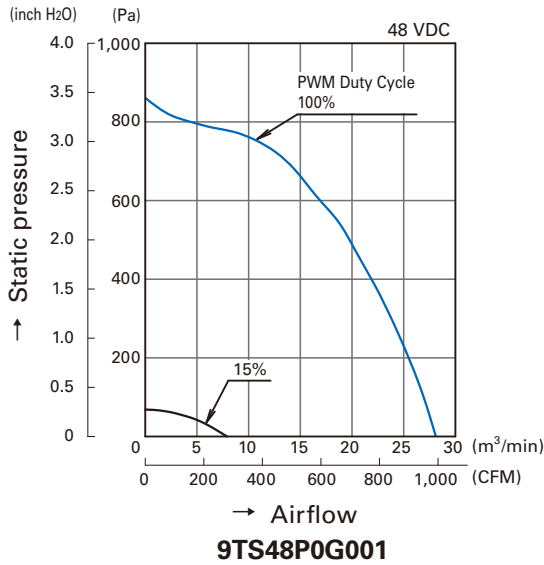

- Operating voltage range

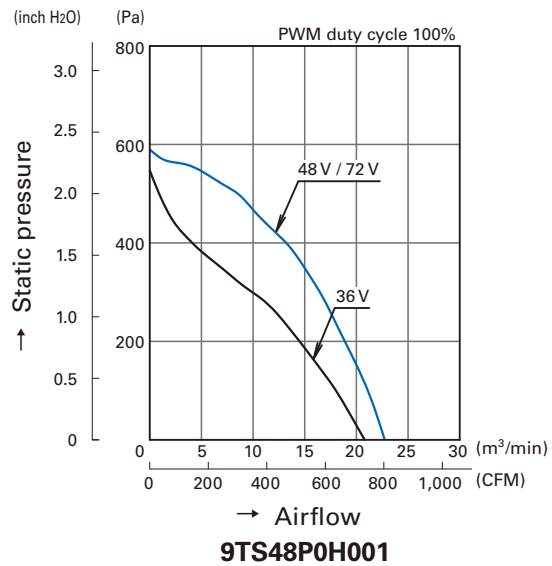
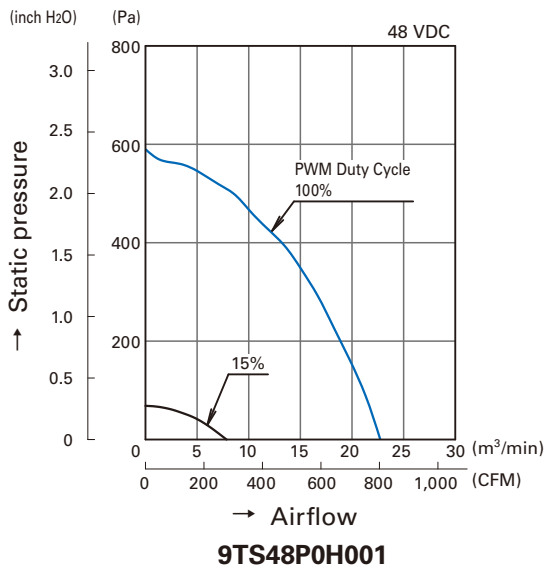
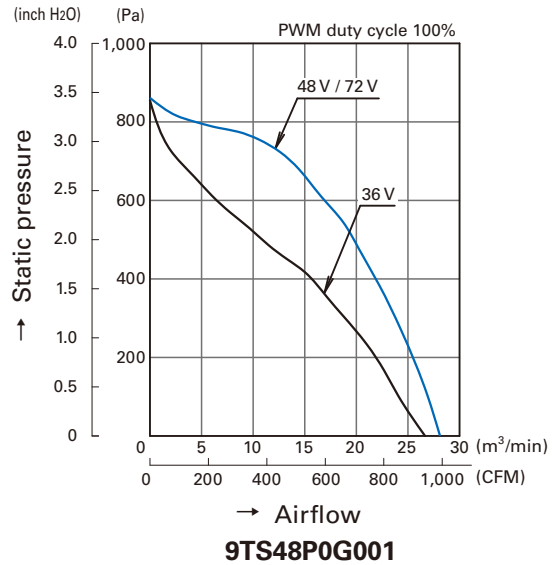

PWM Duty - Speed Characteristics Example

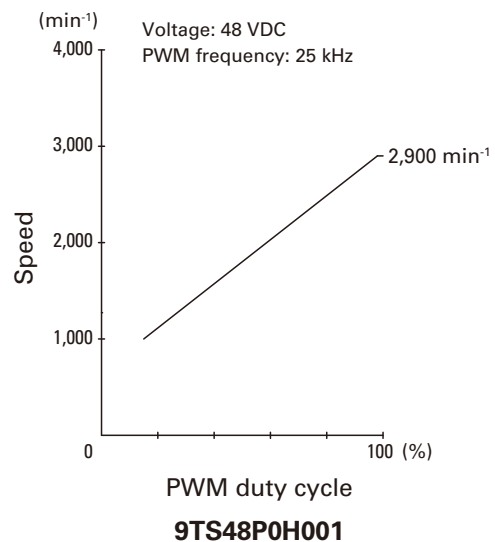
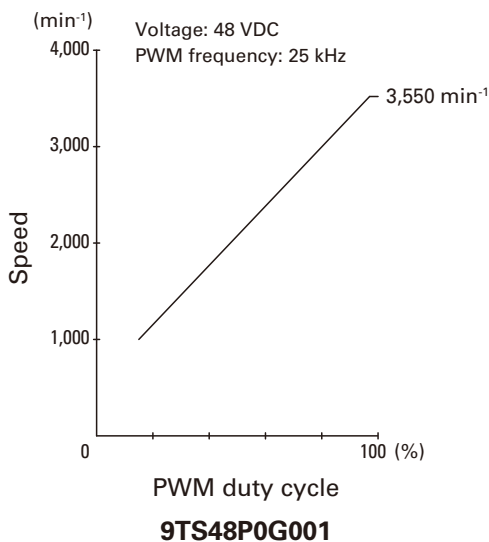

PWM Input Signal Example

Input signal waveform

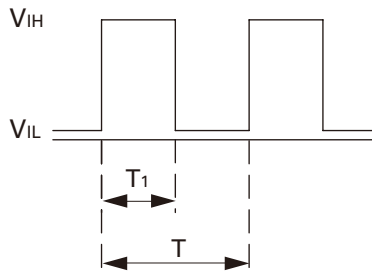

$V_{IH}=4.75\text{ V to }5.25\text{ V}$

$V_{IL}=0\text{ V to }0.4\text{ V}$

$$\text{PWM duty cycle (\%)} = \frac{T_1}{T} \times 100$$

$$\text{PWM frequency } 25\text{ (kHz)} = \frac{1}{T}$$

Source current (I_{source}) : 1 mA max. at control voltage 0 V

Sink current (I_{sink}) : 1 mA max. at control voltage 5.25 V

Control terminal voltage: 5.25 V max. (Open circuit)

When the control lead wire is open, the fan speed is the same as the one at a PWM duty cycle of 100%.

Either TTL input, open collector or open drain can be used for PWM control input signal.

Example of Connection Schematic

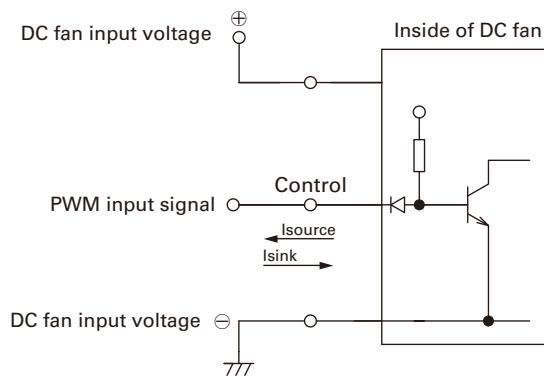

Specifications for Pulse Sensors

Output circuit: Open collector

$V_{CE}=+72\text{ VDC max.}$

$I_c=10\text{ mA max. [}V_{CE}(\text{SAT})=1\text{ V max.]}$

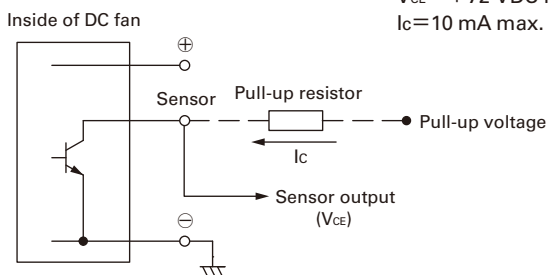

Output waveform (Need pull-up resistor)

In case of steady running

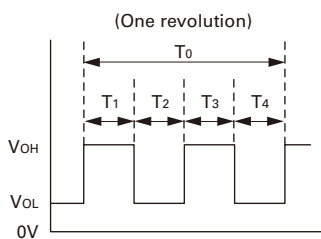

$T_{1\sim 4} \cong (1/4) T_0$

$T_{1\sim 4} \cong (1/4) T_0 = 60/4N\text{ (sec)}$

$N = \text{Fan speed (min}^{-1}\text{)}$

Dimensions (unit: mm)

Fan

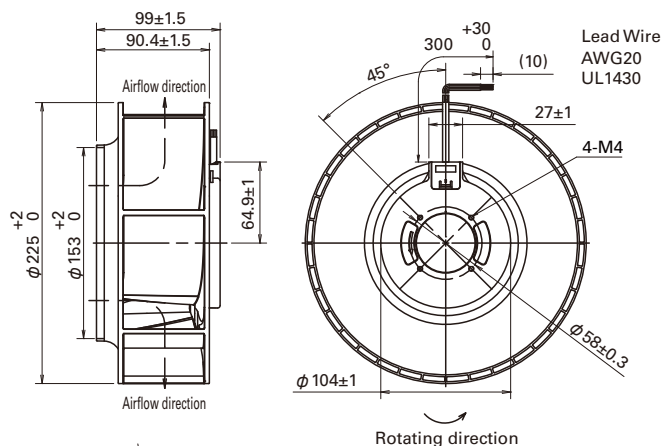

Inlet nozzle
 (Model: 109-1134)
 Material: Steel sheet
 Surface treatment:
 Electro nickel plating (silver)
 Mass: 360 g

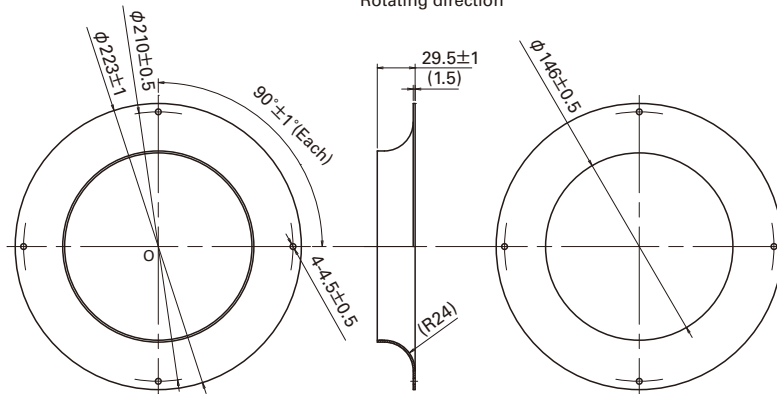

Inlet nozzle: Nozzle mounted in fan inlet side to adjust the flow of introduced air

Reference Dimensions of Mounting Holes and Vent Opening (unit: mm)

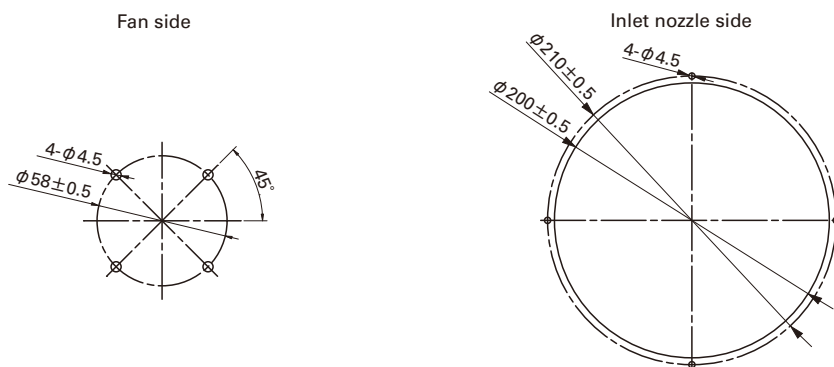

Reference Diagram for Mounting

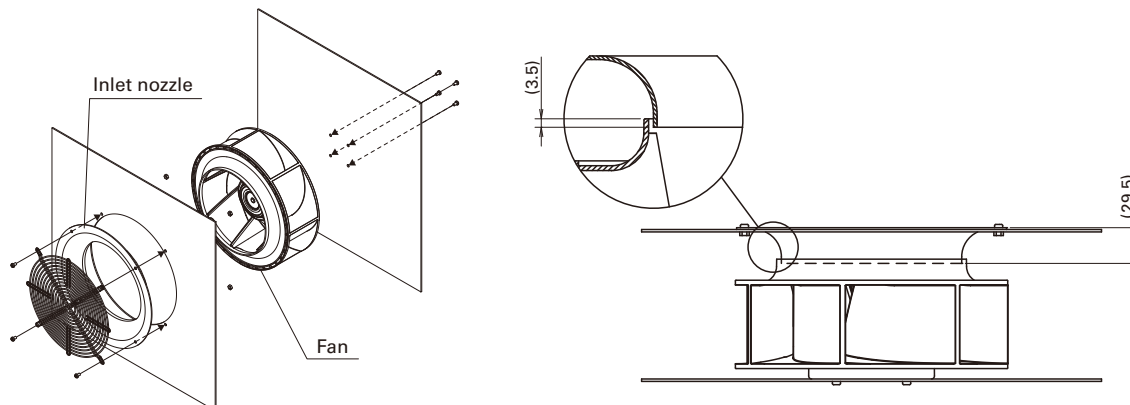

Notice

- Please read the "Safety Instructions" on our website once you have decided on a product for use.
- The products shown in this catalog are subject to Japanese Export Control Law. Diversion contrary to the law of exporting country is prohibited.
- To protect against electrolytic corrosion that may occur in locations with strong electromagnetic noise, we provide fans that are unaffected by electrolytic corrosion.

SANYO DENKI CO.,LTD. 3-33-1, Minami-Otsuka, Toshima-ku, Tokyo, 170-8451, Japan TEL: +81 3 5927 1020

<http://www.sanyodenki.com>

The names of companies and/or their products specified in this catalog are the trade names, and/or trademarks and/or registered trademarks of such respective companies. "San Ace" is a trademark of SANYO DENKI CO.,LTD.

Specifications are subject to change without notice.

CATALOG No. C1047B001 '15.1