

# TBH Series

## 25 Watt TO220 Package Thick Film Power



Ohmite's TBH25 TO220 style resistors are designed for a variety of uses that require intermediate heatsinkable power at an economical price. Engineered for industrial applications, these resistors deliver reliable performance to traditional high-quality Ohmite standards.

### FEATURES

- 25 Watts, @ 25°C case temperature
- Non-Inductive Performance
- Low Thermal Resistance
- Anti-static tube packaging available
- Economically priced
- Resistance element is electrically insulated from metal heat sink mounting tab

### APPLICATIONS

- Power Supplies
- Industrial Controls
- Automotive Steering
- Pre-load/Damping
- Snubber/Bleeder
- Current Sensing

### CHARACTERISTICS

<b>Resistor</b>	Thick film element above 1Ω, Ni-Cu metal element below 1Ω	<b>Test</b>	<b>Condition</b>	<b>Result</b>
<b>Case</b>	High Temperature Plastic	<b>Load Life</b>	(1000hrs @ rated power)	max. ΔR ±1%
<b>Terminals</b>	Solder coated phosphor bronze	<b>Moisture Resistance</b>	(MIL-STD-202, method 106)	max. ΔR ±0.5%
<b>Derating</b>	100% @ 25°C to 0% @ 150°C curve referenced to case temperature	<b>Short Time Overload</b>	(2x rated power, not to exceed 1.5x max. operating voltage)	max. ΔR ±0.3%
<b>Dielectric Strength</b>	1000 VDC	<b>Solderability</b>	(MIL-STD-202, method 208)	
<b>Max. Mounting Torque</b>	0.9Nm	<b>Thermal Shock</b>	(MIL-STD-202, method 107, cond. F)	max. ΔR ±0.3%
<b>Operating Temperature Range</b>	-55°C to +150°C	<b>Terminal Strength</b>	(MIL-STD-202, method 211, cond. A (pull test) 2.4N)	max. ΔR ±0.2%
<b>Temperature Coefficient</b>	0.03-10Ω @ ±100ppm 11Ω-10KΩ @ ±50ppm	<b>Vibration</b>	(MIL-STD-202, method 204, cond. D)	max. ΔR ±0.2%
<b>Thermal Resistance</b>	5°C/W			
<b>Tolerance</b>	5%			
<b>Power</b>	25 Watts. Rating based on 25°C case temperature. The case temperature is to be used for the purposes of establishing the applied power limit. The case temperature must be made with thermocouple contacting the center of the component's mounting tab mounted on designated heat sink.			
<b>Resistance Range</b>	0.03Ω - 10KΩ. Standard values listed at left, others available upon special request.			
<b>Max. Operating Voltage</b>	350V			

(continued)

# TBH Series

## 25 Watt TO220 Package Thick Film Power

### DIMENSIONS

(iin./mm)

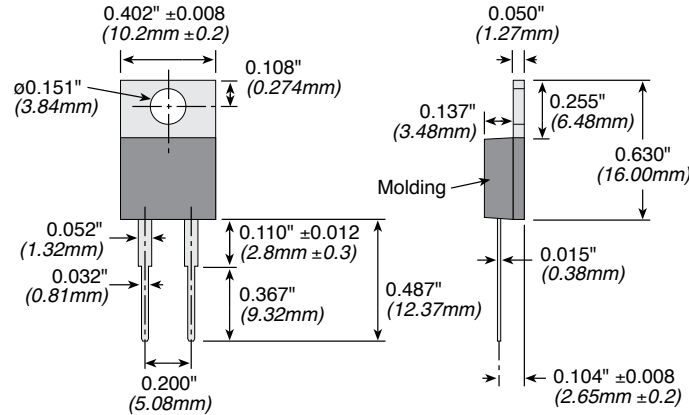

Note: These dimensions apply to TBH products manufactured after March 2007

### ORDERING INFORMATION

RoHS compliant Non-RoHS version unavailable		
<b>T B H 2 5 P 2 R 0 0 J E</b>		
Series	Ohm Value Example: R030 = 0.030Ω 10R0 = 10Ω 1K50 = 1500Ω	Tolerance J = 5%, standard

#### Standard Part Numbers

Ohms	Part Number 5% Tolerance	Ohms	Part Number 5% Tolerance
0.030	TBH25PR030JE	100	TBH25P100RJE
0.036	TBH25PR036JE	150	TBH25P150RJE
0.040	TBH25PR040JE	220	TBH25P220RJE
0.047	TBH25PR047JE	240	TBH25P240RJE
0.050	TBH25PR050JE	330	TBH25P330RJE
0.075	TBH25PR075JE	470	TBH25P470RJE
2	TBH25P2R00JE	510	TBH25P510RJE
7.5	TBH25P7R50JE	1000	TBH25P1K00JE
10	TBH25P10R0JE	1500	TBH25P1K50JE
15	TBH25P15R0JE	2000	TBH25P2K00JE
22	TBH25P22R0JE	2700	TBH25P2K70JE
30	TBH25P30R0JE	10,000	TBH25P10K0JE
33	TBH25P33R0JE		
47	TBH25P47R0JE		
51	TBH25P51R0JE		
75	TBH25P75R0JE		

### THIS PRODUCT IS DESIGNED FOR USE WITH PROPER HEATSINKING.

Maximum base plate temperature of the resistor must be monitored and kept within specified limits to establish the power rating. Best technique is to attach a thermocouple to the side of the base plate of the resistor. Temperature of plastic housing or heat sink cannot be used to establish rating of the resistor.