

ALL DIMENSIONS ARE IN INCHES

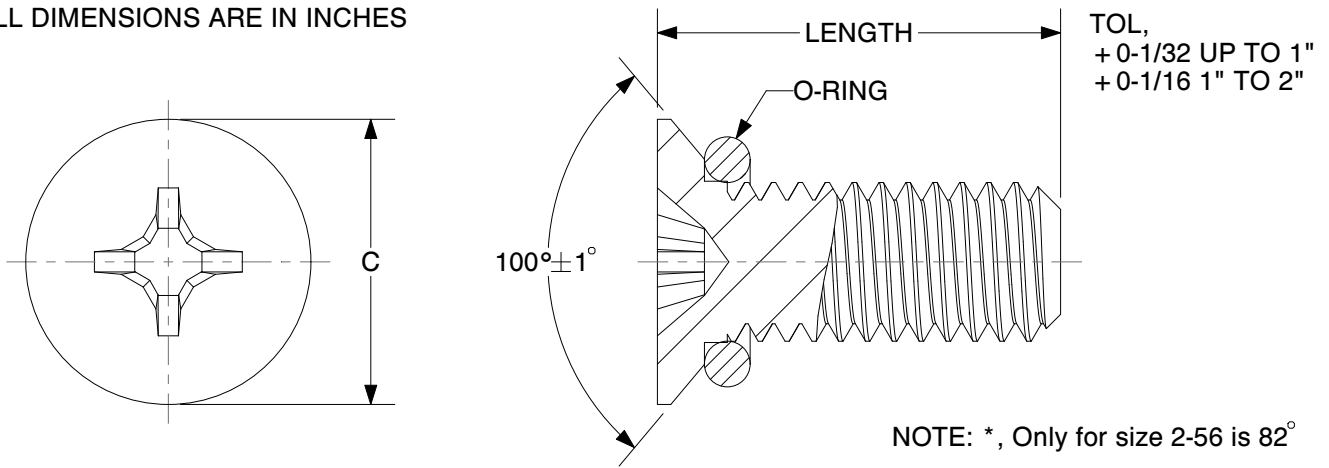

NOTE: \*, Only for size 2-56 is 82°

THREAD SIZE	C max	Head driver size	RECOM. CLEAR. HOLE		LENGTH	DEPTH
			MIN.	MAX.		
*2-56 UNC-2A	0.172"	#1	0.091"	0.95"	1/4" TO 1" Incl.	0.035"-0.052"
4-40 UNC-2A	0.225"	#1	0.125"	0.129"	1/4" TO 1" Incl.	0.050"-0.075"
6-32 UNC-2A	0.279"	#1	0.147"	0.152"	1/4" TO 1" Incl.	0.062"-0.093"
8-32 UNC-2A	0.332"	#2	0.173"	0.179"	1/4" TO 1" Incl.	0.062"-0.093"
10-24 UNC-2A	0.385"	#2	0.199"	0.204"	5/16" TO 1" Incl.	0.082"-0.123"
10-32 UNC-2A	0.385"	#2	0.199"	0.204"	5/16" TO 1" Incl.	0.062"-0.093"
1/4-20UNC-2A	0.507"	#3	0.265"	0.269"	3/8" TO 1" Incl.	0.100"-0.150"

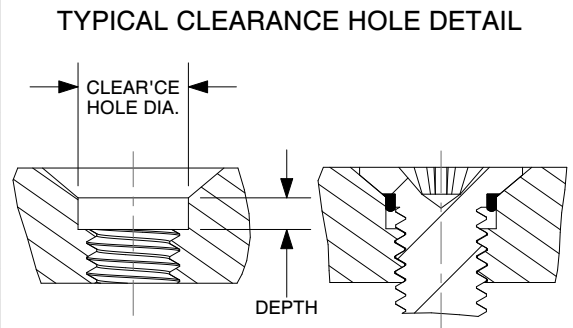

**STANDARD SPECIFICATIONS & COMMON OPTIONS (HOW TO ORDER)**

STD. SCREW MATERIAL: TYPE 18/8 STAINLESS STEEL PER DFARS (OTHER MATERIAL AVAILABLE)  
 STD. SCREW FINISH: NATURAL (PASSIVATED PER AMS2700 UNLESS OTHERWISE SPECIFIED)  
 STD. O-RING MATERIAL: SILICONE RUBBER (SEE TABLE FOR O-RING OPTIONS)

SAMPLE CATALOG NO.		SFR4-40X1/4-2701-BLKOX	AVAILABLE O-RING MATERIALS			COMMON OPTIONS	
SCREW TYPE	SFR	FLAT HEAD WITH C'SUNK RECESS	Compound Suffix	Material	Service Temp.	SUFFIX	DESCRIPTION
THREAD	4-40	ENTER BASIC THREAD SIZE	-2701	Silicone Rubber	-150° F to 500° F -101° C to 260° C	-BLKOX	BLACK OXIDE PER MIL-C-13924, CLASS 4
LENGTH	1/4	ENTER LENGTH	-2615	Fluoro-Silicone Rubber	-78° F to 450° F -61° C to 232° C	-NY	LOCKING NYLON PELLET
O-RING SUFFIX	-2701	ENTER FROM TABLE	-5701	Viton A	-20° F to 400° F -29° C to 204° C	-LY	LOCKING NYLON STRIP
OPTIONS	-BLKOX	ENTER FROM TABLE	-4601	Buna N (NBR)	-65° F to 250° F -54° C to 121° C	-TP	LOCKING NYLON STD. PATCH
			-3701	Neoprene (EPR)	-65° F to 300° F -54° C to 149° C	-HTP	HIGH TEMP. LOCKING NYLON PATCH
			-7601	Ethylene Propylene (EPDM)	-65° F to 300° F -54° C to 149° C		

O	ECO-14-0010: CORRECTED ATTACHMENTS POINTS FOR CLEAR'CE HOLE DIA. DIMENSION. DWN: D. LAW	CHKD BY: KF/FK	12.01.14
N	CHANGED PASSIVATED FROM MIL-STD-171 TO AMS 2700 & BLKOX TO MIL-C-13924, CL.4		11.05.13
M	CHANGED HEAD DRIVER SIZE OF 6-32 FROM #2 TO #1	S. GOK	01.27.10
REV.	DESCRIPTION		DATE

MAXIMUM AND MINIMUM MEASUREMENTS ARE STATED DIRECTLY ON EACH DIMENSION.	TITLE: <b>SEELSKREW® , FLATHEAD C'SUNK, RECESSED</b>	ENG.	M.M.	10.24.58
		DWN.	J.P.	10.24.58
MAT'L: AS NOTED	APM-HEXSEAL CORPORATION	CHKD.	FK	11.21.13
		SCALE	DWG. NO.	<b>SFR-0000-00-00</b>
FINISH: AS NOTED				

THIS DRAWING COVERS PROPRIETARY ITEM AND IS THE PROPERTY OF THE APM-HEXSEAL CORPORATION. THIS DRAWING IS NOT TO BE COPIED OR USED WITHOUT THE WRITTEN APPROVAL OF AN OFFICER OF THE APM-HEXSEAL CORPORATION.