

AMBASSADOR SERIES COUNT CONTROL

MODELS:



57600-404 (10-15 VDC)
57601-404 (115 VAC)
57601-454 (Red Display)
57602-404 (230 VAC)

- Six Digit, Dual Preset Main Counter
- Six Digit, Single Preset Batch Counter
- Eight Digit Totalizer
- 1/Tau Rate Meter
- Counter and Rate Meter Scaling
- Four User-Configurable Control Inputs
- Two Output Relays
- Two Solid State Outputs
- RS-485 Serial Communications
- Red or Green Display

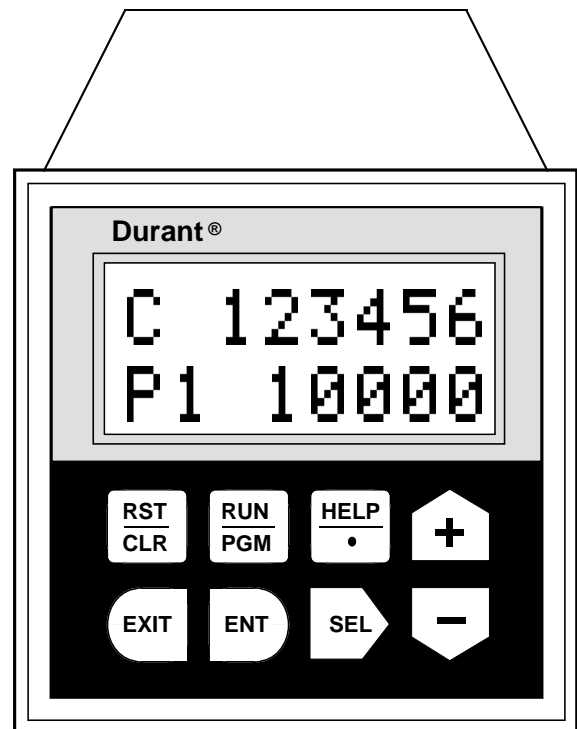

TABLE OF CONTENTS

1	Introduction
3	Front Panel Features
4	Run Mode Operation
5	Programming
12	Scale Factors
13	Rear Terminal Description
15	Wiring Diagrams
18	Serial Communications
24	Diagnostics and Troubleshooting
26	Specifications
27	Parts and Accessories
28	Dimensions

INTRODUCTION

GENERAL DESCRIPTION

The Durant Ambassador 5760X-404 is a count control device with three count registers - main counter, batch counter and totalizer. The main counter has two presets and is well suited for controlling processes which require two levels of control such as a slow down mode before stopping. The batch counter counts the number of times the main counter has cycled and typically represents values like: pieces cut, containers filled, cartons made and etc. The batch preset is useful for signaling or stopping the process when the desired amount of product is completed. The totalizer accumulates the total number of counts processed by the main counter. Its value represents the total amount of material used by a process or the total number of pieces processed.

PROGRAMMABLE I/O

One of the unique features of the Ambassador family of counters is the programmability of the inputs and outputs. Each of the four inputs can be independently programmed to perform one of nine functions. The user can also select which events (counter preset outputs, reset signals, output control inputs, output timers, and serial commands) cause each of the four outputs (2 relay and 2 transistor) to pick-up and drop-out. Any input(s) may be programmed for output control, however, multiple output control inputs are paralleled into a single output control channel in the unit.

DISPLAY

All Ambassador Count/Controls are available in green backlit LCD display and reverse image red LCD display versions.

MENU PROGRAMMING

Another unique feature of the Ambassador family of counters is the menu driven programming. The two line alphanumeric display prompts programming choices, thus eliminating the need to remember or look up programming codes. A non-volatile memory retains programming choices, presets, and count values while power is removed.

RATE METER

In addition to count/control capabilities, a rate meter is provided to monitor the speed of the incoming count signal. This rate feature uses the 1/tau method (event time measurement) and can calculate and scale the rate so that even a low count speed (.1 Hz) can yield accurate rates in engineering units (ft/sec, gal/min, etc). The rate feature operates simultaneously with the count/control functions.

APPLICATION

To better understand the features and capabilities of the Ambassador, review the simplified block diagram at the top of the next page and the programming diagrams on pages 6 through 9. Because of the Ambassador's versatility, both programming and wiring decisions must be made before the counter can be operated. The following sequence of activities is recommended:

1. Answer the following questions:
 - What should each count register represent?
 - What should each output control or do?
 - What effect should each preset have on the outputs?
 - What should cause each count register to reset?
 - Which control signals should affect outputs (resets, programmable inputs, output timers, etc)?
 - What engineering units should the rate represent?
2. Go through the programming section and mark the choices required for the application.
3. Go through the wiring section and lay out the wiring required. Remember that wiring is affected by programming.
4. Wire and program the counter as determined in steps 2 and 3 above.

BLOCK DIAGRAM / OVERVIEW

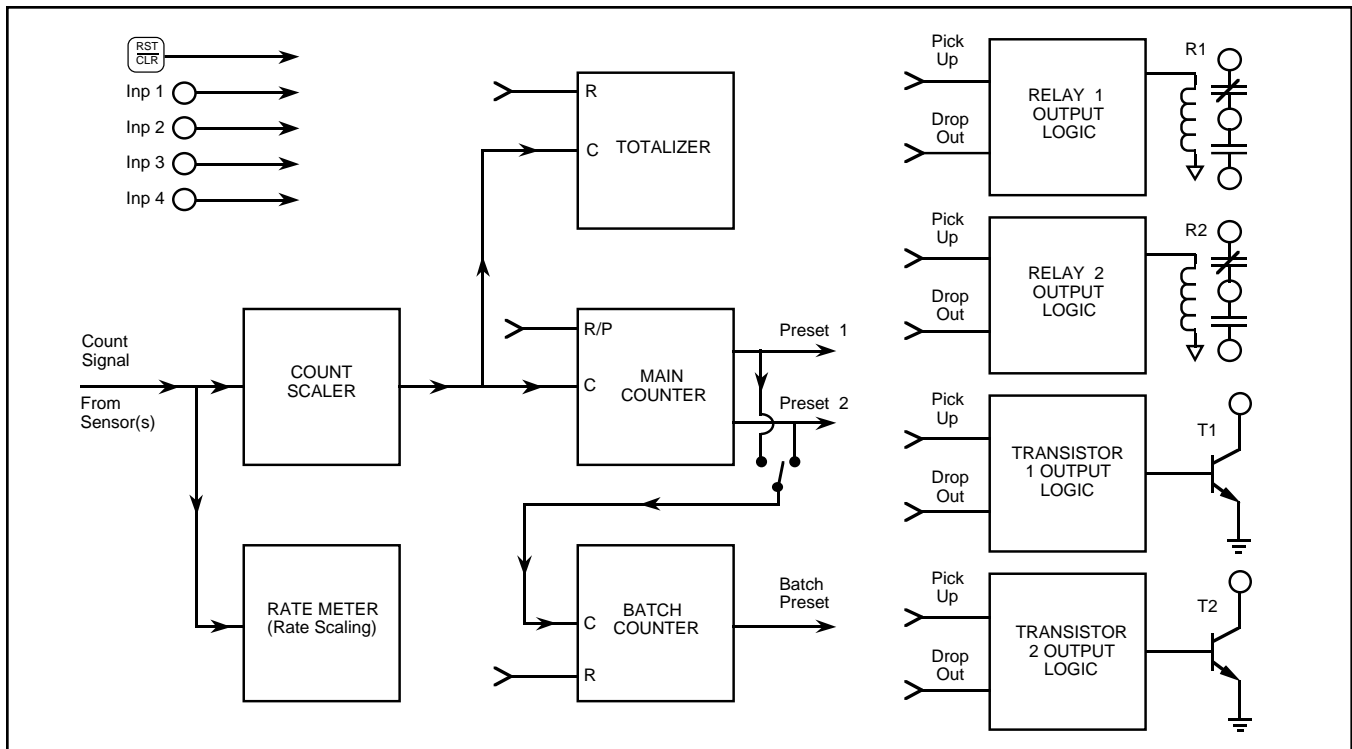

COUNT SCALER

Receives the up or down signals and adds or subtracts the scale factor value to/from the current scaler remainder. The scaler outputs the integer result as up or down pulses. The fractional portion of a count remaining is stored in the scaler's memory.

MAIN COUNTER

Counts the up and down pulses from the scaler. Every two milliseconds, the main counter checks if its value has passed through either of the preset values (coincidence). For coincidence to occur, the counter must count up to a preset in the reset to zero mode and count down to preset 1 or zero in the reset to preset 2 mode. If coincidence has occurred, the main counter outputs a pulse on the corresponding preset 1 or preset 2 output. The main counter counts in the opposite direction if it is programmed to reset to preset 2.

BATCH COUNTER

Counts up when main counter auto-cycles. If auto-cycle is disabled, the batch counter increments when the main counter reaches preset 2. Every two milliseconds, the batch counter checks if its value has passed through the preset value (coincidence). If coincidence has occurred, the batch counter outputs a pulse on the batch output.

PROGRAMMABLE INPUTS

The Ambassador unit has five programmable inputs (RST/CLR key and four terminals). The user may program each input for one of nine functions (see INPUTS, page 10).

RELAY AND TRANSISTOR OUTPUT LOGIC

These blocks act like latching relays. When the pick-up input receives a pulse, the output turns on and stays on until it times out or until the dropout input receives a pulse.

RATE METER BLOCK

The Rate Meter block measures the time duration of a pulse or group of pulses received at input A. It uses this measurement along with the rate scaler to calculate the rate in meaningful units. Internal logic resets the rate meter if the count direction reverses.

TOTALIZER

Counts the up and down pulses from the scaler. The totalizer and main counter count in opposite directions if the main counter is programmed to reset to the preset 2 value.

FRONT PANEL FEATURES

Two line LCD Display - Shows count, preset, and rate values when the unit is in the run mode. Displays programming information when the unit is in the program mode.

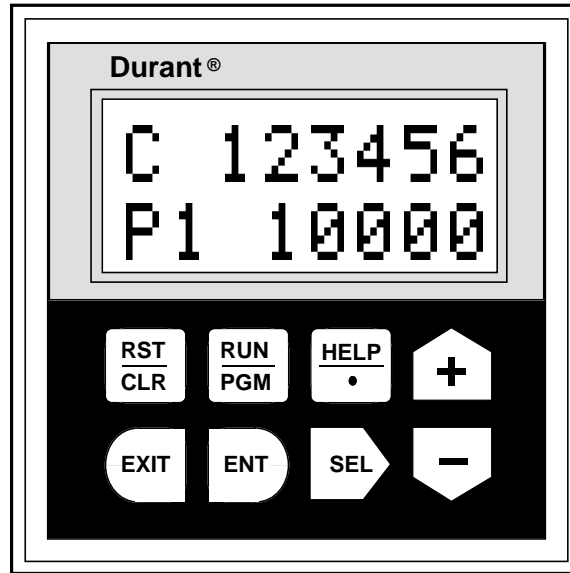

Key Functions



Reset/Clear Key - This key can be programmed to reset count values when in the run mode. In the preset editing mode this key zeros presets that are being changed. In the program mode it zeros numeric data that is selected for editing.



Run/Program Key - Press this key followed by the Enter key (ENT) to enter the program mode. Pressing this key while in the program mode returns the control to the run mode.



Help/Key - In the run mode this key causes the Help Screens to be displayed. In the program mode this key is used to set the decimal point positions for count and rate scaler displays.



Up Arrow/Plus (+) Key - In the run mode this key is used to scroll up through the six different display screens. In the preset editing mode this key adds 1 (increments) to the value of the selected digit each time it is pressed. In the program mode this key is used to step vertically up through the menus and increment the value of selected digits when changing numeric values.



Exit Key - In the preset editing mode this key allows the preset editing process to be exited without altering the previous preset value. In the program mode this key exits program changes that have been selected but not yet entered.



Enter Key - In the run mode this key causes preset changes to take effect. In the program mode it causes the displayed program changes to be entered.



Select Key - In run mode this key allows the editing of presets and selects individual digits of the preset. In program mode this key is used to move into more detailed menus and selects the digits of numeric values needed for programming.



Down Arrow/Minus (-) Key - In the run mode this key is used to scroll down through the six different display screens. In the preset editing mode this key subtracts 1 (decrements) from the value of the selected digit each time it is pressed. In the program mode this key is used to step vertically down through the menus and decrement the value of selected digits when changing numeric values.

RUN MODE OPERATION

SELECTING DISPLAY INFORMATION

The Ambassador control has six available run mode displays. Use the up and down arrow keys to select the desired display.

The selected display will remain on until one of the arrow keys is pressed to cause a change.

The screen selected for display during run-mode only provides information to the operator and does not affect the operation of the control.

If power is removed and restored, the unit will power-up with the display that was last selected.

RUN MODE MENUS

The keystroke sequence used to access all of the available run mode screens and change preset values is shown in a menu format below.

CHANGING PRESET VALUES

Preset 1, preset 2 and batch preset are set as follows:

1. Use the up and down arrow keys to select one of the three preset screens.
2. Press the SEL key to enter the preset change mode. The display will show all digits of the preset value. The left-most digit will flash indicating that it is currently selected. To set the preset to zero, press the RST/CLR key.
3. Use the SEL key to select the digit to be changed. Each time the key is pressed, the next digit to the right is selected. The digit value can then be changed using the up and down arrow keys.
4. Press the ENT key to enter the new preset value and return to the run mode screens. Press the EXIT key at any time to abort preset changes.

All count and control functions continue to operate when preset values are being changed.

Run Mode Menu Illustration

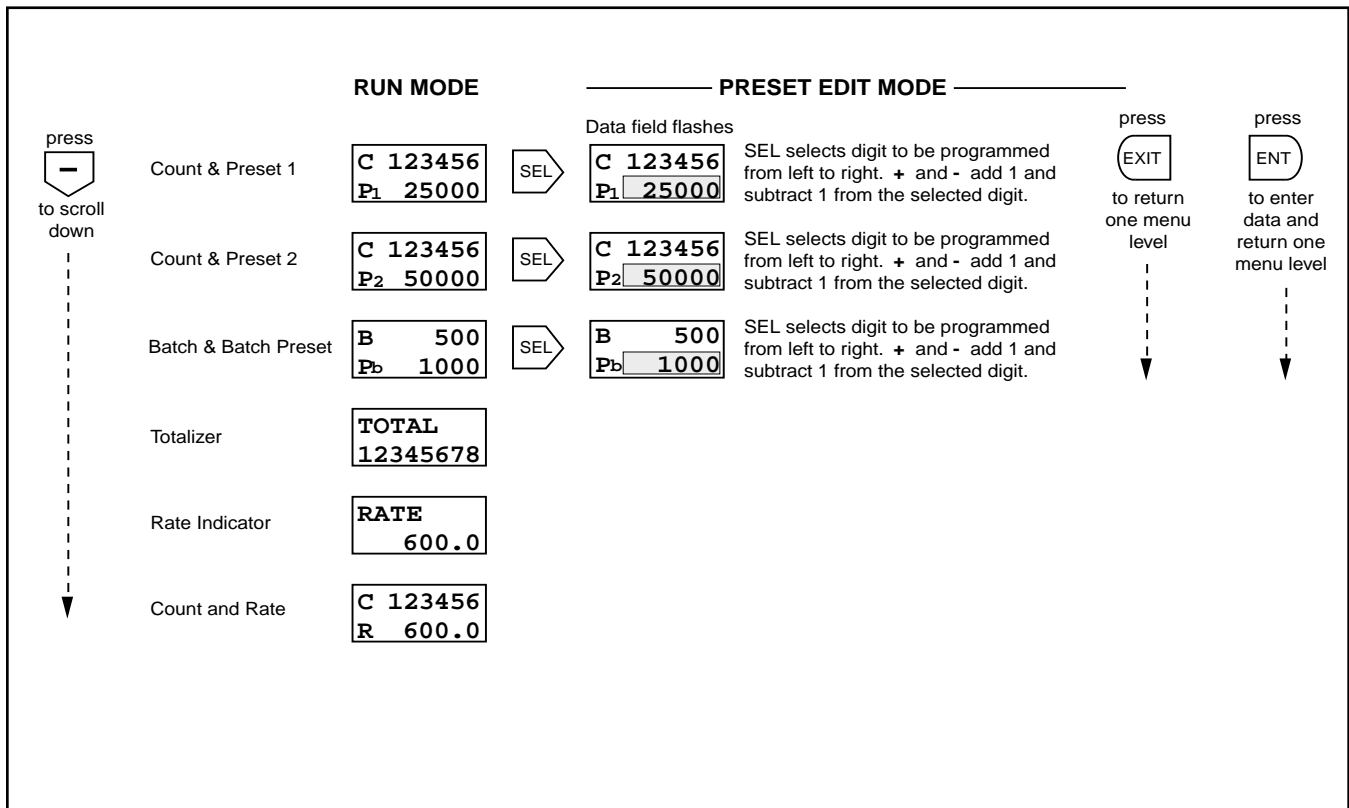

PROGRAM MODE

INTRODUCTION TO MENU PROGRAMMING

The menu programming format used by the Ambassador series eliminates the need to memorize or look up programming options. Program prompting is provided on the 2 line alphanumeric display.

The programming menus are organized in a manner much like an outline. The main menu items are located out to the far left column and each successive subdivision of these main items is located one column further to the right.

The keystroke sequences to select all of the programmable options are shown in the programming charts on pages 7-10. The seven main menus are shown below.

ENTERING THE PROGRAM MODE



Press  Then  To enter program mode

The ENT key must be pressed within five seconds, otherwise the display will return to the last run mode menu.



Caution: entering the Program Mode will cause all outputs to turn off. Make sure process is stopped before entering the Program Mode.

Overview of Main Menus

press  to scroll down	
PROGRAM SCALERS	Enter count scale factor and decimal point, rate scale factor and decimal point.
PROGRAM COUNT IN	Select count mode, reset to zero or reset to preset and auto-recycle operations.
PROGRAM INPUTS	Select the input function to be performed by each to the four programmable inputs.
PROGRAM OUT MODE	Select normal or reverse logic, latched or pulsed, pick-up and drop-out events.
PROGRAM SER PORT	Select the unit I.D. number, baud rate, parity, and transmission delay.
PROGRAM SER OUT	Select the data items to be transmitted when a serial group print command (RCD7) is received.
PROGRAM OPTIONS	Select the run mode function of the front panel RST/CLR key. Restore factory programming.
press  to scroll up	

PROGRAMMING SCALERS AND COUNT INPUTS

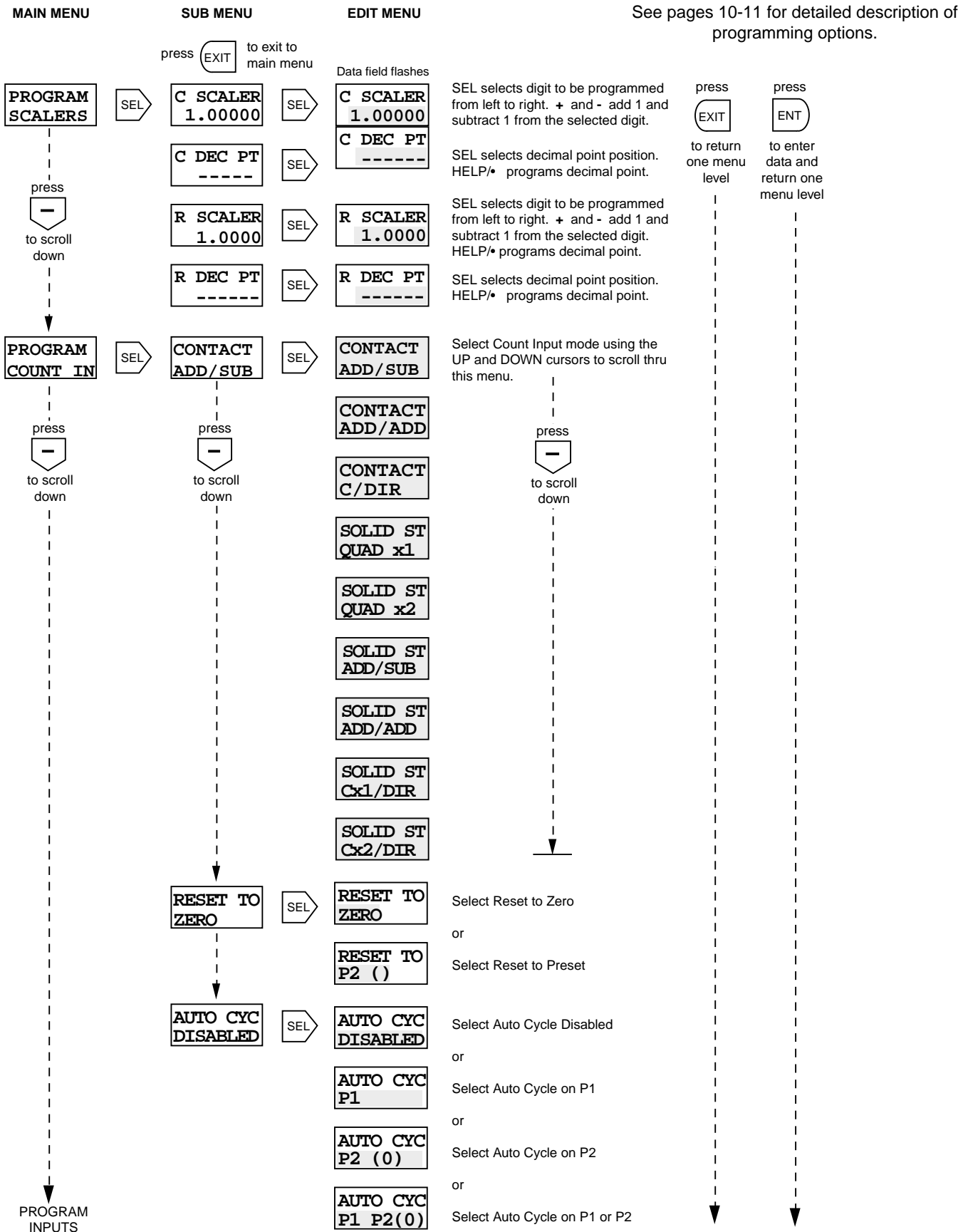

PROGRAMMING CONTROL INPUTS

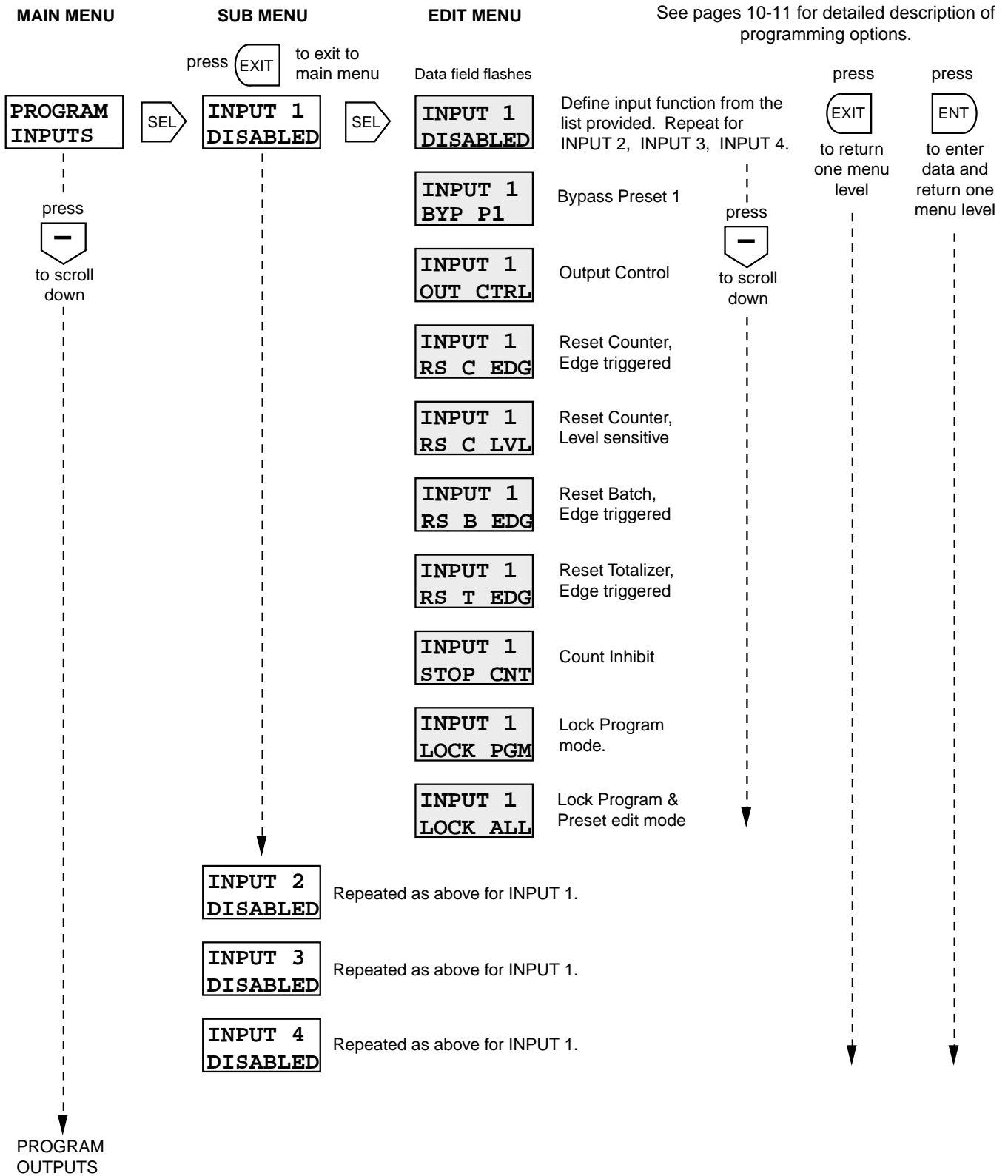

PROGRAMMING OUTPUTS PROGRAMMING CONTROL INPUTS

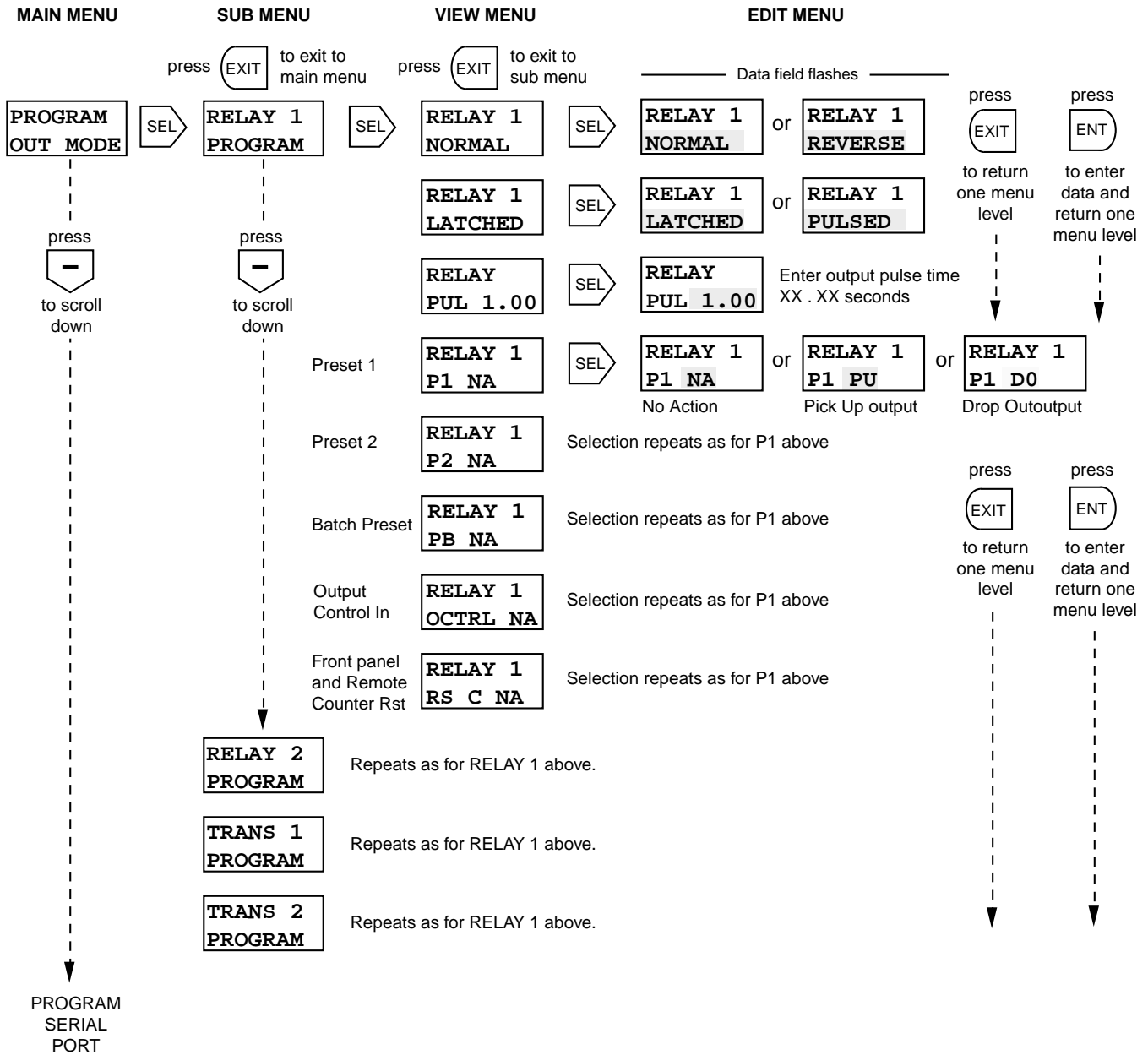

See pages 10-11 for detailed description of programming options.

PROGRAMMING SERIAL PORT AND OPTIONS

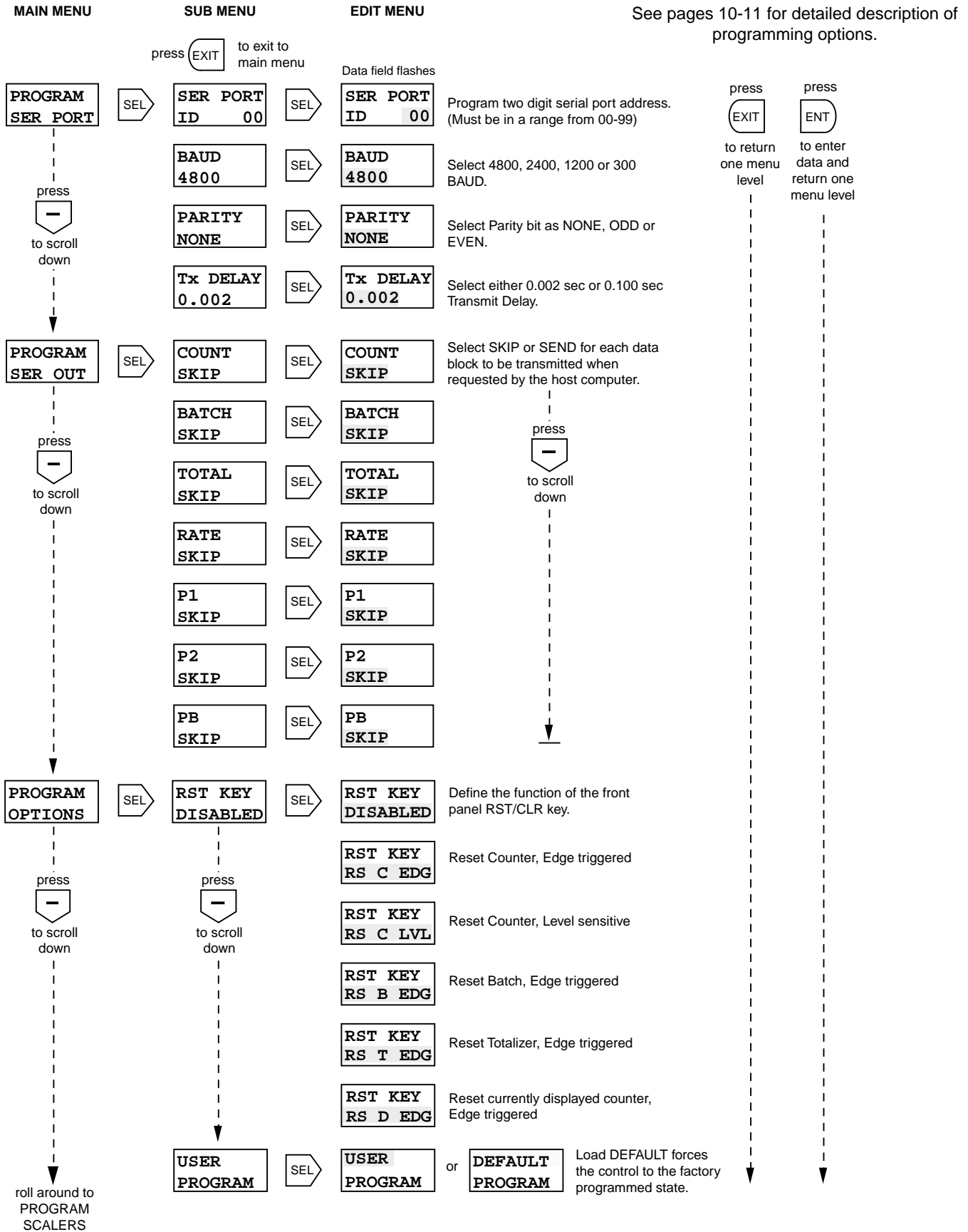

DESCRIPTION OF PROGRAM OPTIONS

SCALERS

C SCALER — the count scaler determines the value of each input pulse. The counter displays whole numbers only. The count scale factor affects the main counter and totalizer but does not affect the rate meter. The count scaler's decimal point position is fixed.

C DEC PT — sets the decimal point position for the main counter and totalizer. The decimal point position and scale factor value are independent.

R SCALER — the rate scaler is used to adjust the rate meter reading and compensate for the number of input pulses per item. The rate scaler's decimal point is programmable. The rate scaler and count scaler are independent.

R DEC PT — sets the decimal point position for the rate display. The rate decimal point position and scale factor value are independent.

COUNT INPUT

CONTACT ADD/SUB — input A adds counts and input B subtracts counts. This mode includes input filtering to debounce mechanical contacts.

CONTACT ADD/ADD — inputs A and B both add counts. This mode includes input filtering to debounce mechanical contacts.

CONTACT C/DIR — count with direction control. Input A adds counts when the B input is high. Input A subtracts counts when the B input is low.

SOLID ST QUAD x1 — requires a quadrature signal input. This mode provides direction control and is used to eliminate false counts due to jitter or vibration. The count direction depends on the phase relationship of inputs A and B.

SOLID ST QUAD x2 — same as the quadrature x1 mode above; except that counts occur on both edges of input signal. This allows increased resolution from the same pulse source.

SOLID ST ADD/SUB — same as the contact add/subtract mode but can be used with high speed count signals.

SOLID ST ADD/ADD — same as the contact add/add mode, but can be used with high speed count signals.

SOLID ST C x1/DIR — same as contact count/direction, but can be used with high speed count signals.

SOLID ST C x2/DIR — same as above, except counts occur on both edges of input signal for increased resolution.

RESET TO ZERO — the main counter resets to zero when a main counter reset occurs. The normal count direction is up.

and the main counter outputs respond only when counting up.

RESET TO P2 () — the main counter resets to the preset 2 value when a main counter reset occurs. Preset 2 coincidence occurs when the main counter reaches zero. The normal count direction is down and the main counter outputs respond only when counting down.

AUTO CYC DISABLED — the main counter does not automatically reset when it reaches a preset value.

AUTO CYC P1 — the main counter automatically resets as programmed when it reaches the preset 1 value.

AUTO CYC P2(0) — the main counter automatically resets as programmed when it reaches the preset 2 coincidence value. The preset 2 coincidence value is zero when in the reset to preset mode.

AUTO CYC P1 P2(0) — the main counter automatically resets as programmed when it reaches preset 1 or the preset 2 coincidence value. The preset 2 coincidence value is zero when in the reset to preset mode.

INPUTS

INPUT 1 DISABLED — input 1 does not perform any function when turned on.

INPUT 1 BYP P1 — the counter ignores preset 1 when input 1 is on (level sensitive).

INPUT 1 OUT CTRL — when input 1 is turned on, an output control signal occurs (edge sensitive). While more than one input may be programmed for output control, only one output control channel is available in the unit.

INPUT 1 RS C EDG — the main counter resets when input 1 is turned on (edge sensitive). If input 1 remains on, the main counter can still count.

INPUT 1 RS C LVL — the main counter is held at the reset value while input 1 is on (level sensitive).

INPUT 1 RS B EDG — the batch counter resets when input 1 is turned on (edge sensitive). If input 1 remains on, the batch counter can still count.

INPUT 1 RS T EDG — the totalizer resets when input 1 is turned on (edge sensitive). If input 1 remains on, the totalizer can still count.

INPUT 1 STOP CNT — all count functions stop (inhibited) while input 1 is on (level sensitive).

INPUT 1 LOCK PGM — all program editing is disabled (keyboard and serial) while input 1 is on (level sensitive).

DESCRIPTION OF PROGRAM OPTIONS

Preset values can still be changed serially or from the keyboard.

INPUT 1 LOCK ALL — all programming and preset editing functions (keyboard and serial) are disabled while input 1 is on (level sensitive). The user can still select different run mode displays from the keyboard.

Each of the above functions are repeated for inputs 2, 3, and 4 respectively.

OUTPUT MODE

RELAY 1 NORMAL — relay 1 turns on when it receives a pickup signal and turns off when it receives a dropout signal.

RELAY 1 REVERSE — relay 1 turns on when it receives a dropout signal and turns off when it receives a pickup signal. The relay always powers-up in the off state.

RELAY 1 LATCHED — relay 1 turns on (off if reversed) when it receives a pickup signal and stays on (off if reversed) until it receives a dropout signal.

RELAY 1 PULSED — relay 1 turns on (off if reversed) when it receives a pickup signal and automatically turns off (on if reversed) after the time specified below.

RELAY 1 PUL — enter the desired time for relay 1 to stay on (00.01 to 99.99 seconds). This screen is not displayed unless pulsed is selected in the menu above.

RELAY 1 P1 — relay 1 can be programmed for no action, pickup or dropout when the main counter reaches preset 1.

RELAY 1 P2 — relay 1 can be programmed for no action, pickup or dropout when the main counter reaches preset 2.

RELAY 1 PB — relay 1 can be programmed for no action, pickup or dropout when the batch counter reaches the batch preset.

RELAY 1 OCTRL — relay 1 can be programmed for no action, pickup or dropout when an output control signal occurs. One of the inputs must be programmed for output control before a RELAY 1 OCTRL can occur.

RELAY 1 RS C — relay 1 can be programmed for no action, pickup or dropout when a reset main counter signal occurs. The reset key or one of the inputs must be programmed to reset the main counter before a RELAY 1 RS C can occur.

Each of these functions is repeated for relay output 2, transistor output 1 and transistor output 2 sub-menus.

SERIAL PORT

SER PORT ID — enter the desired two digit serial ID number (00-99 decimal). All communications to the control must contain this number (in hexadecimal). Each unit must have a unique ID#.

BAUD — selects the serial port transmit and receive baud rate. Allowable rates are 19200*, 9600*, 4800, 2400, 1200, and 300. *Version 5 firmware or later. To check firmware version, press Help key twice from run mode. First two digits (top left) should read "25" or greater for version 5 or later.

PARITY — the user may select none, odd, or even parity. If none (no parity) is selected, the counter transmits space parity and does not check received parity.

Tx DELAY — the user may select a transmission delay of either 2 or 100 milliseconds. The counter waits for this time period before responding to any serial commands. This delay is provided to allow a host computer time to switch from the transmit to receive mode.

SERIAL OUT

These options determine which items are sent when the counter receives the RCD7 command.

OPTIONS

RST KEY DISABLED — the RST/CLR key does not perform any function.

RST KEY RS C EDG — the main counter resets when the RST/KEY is pressed (edge sensitive). If the RST/KEY is held on, the main counter can still count.

RST KEY RS C LVL — the main counter is held at the reset value while the RST/KEY is pressed (level sensitive).

RST KEY RS B EDG — the batch counter resets when the RST/CLR key is pressed (edge sensitive). If the RST/CLR key is held on, the batch counter can still count.

RST KEY RS T EDG — the totalizer resets when the RST/CLR key is pressed (edge sensitive). If the RST/CLR key is held on, the totalizer can still count.

RST KEY D EDG — any counter value being displayed is reset when the RST/CLR key is pressed (edge sensitive). If the RST/CLR key is held on, the displayed counter can still count.

USER/DEFAULT PROGRAM — if the user selects default, the counter returns all program mode options to the factory set values (first choice shown in menus). Counter and preset values are not affected. This screen shows USER PROGRAM if any options have been changed from the default settings.

CALCULATING SCALE FACTORS

COUNT SCALING

The count scaler is a user programmable number which determines the count value of each input pulse. It is used to correct for a known amount of error (wheel wear, viscosity, etc.) or to convert the incoming count signal into the desired units of measure on the display (feet, gallons, yards, etc.). The main counter and totalizer show whole (integer) counts; the scaler retains fractional counts.

Count Scaler Range: 0.00001 to 9.99999

Default Count Scaler: 1.00000

Count Scaler (CS) Formula:

$$CS = \frac{DPF}{PPI}$$

where:

DPF is the decimal point factor determined by the desired decimal point position on the main counter and totalizer display:

DISPLAY	DPF	DISPLAY	DPF
XXXXXX	= 1	XXX.XXX	= 1,000
XXXXX.X	= 10	XX.XXXX	= 10,000
XXXX.XX	= 100	X.XXXXX	= 100,000

(Use the counter decimal point menu to select the desired decimal point position for the main counter and totalizer.)

PPI is the number of pulses per item from the sensor (times 2 if doubled count mode).

Example 1: A sensor produces 20 pulses per inch of material travel. Calculate the count scaler required to indicate material used in whole inches (XXXXXX).

$$CS = \frac{1}{20} = 0.05000$$

Example 2: An encoder produces 120 pulses per foot. Calculate the count scaler required to indicate material usage in 1/100's of feet (XXXX.XX).

$$CS = \frac{100}{120} = 0.83333$$

(Select the XXXX.XX position on the counter decimal point menu).

RATE SCALING

The 1/Tau rate meter calculates rate by measuring the time interval between input pulses, converting to frequency, and multiplying by the rate scaler. The rate scaler is user programmed to convert the count input pulse frequency into the desired units for display (feet/minute, inches/second, boxes/hour, etc.).

Rate Scaler Range: 0.00001 to 99999

Default Rate Scaler: 1.0000

Rate Scaler (RS) formula:

$$RS = \frac{SEC \times DPF}{PPI}$$

where:

SEC is the number of seconds in the rate time unit (items/minute = 60, items/hour = 3600, etc.).

DPF is the decimal point factor determined by the desired decimal point position on the rate meter display:

DISPLAY	DPF	DISPLAY	DPF
XXXXXX	= 1	XXX.XXX	= 1,000
XXXXX.X	= 10	XX.XXXX	= 10,000
XXXX.XX	= 100	X.XXXXX	= 100,000

(Use the rate decimal point menu to select the desired decimal point position for the rate meter.)

PPI is the number of pulses per item from the sensor (times 2 if doubled count mode).

Example 1: A sensor produces 1 pulse per foot of material travel. Display rate in whole feet per minute (XXXXX).

$$RS = \frac{60 \times 1}{1} = 60.000$$

Example 2: A flow sensor produces 400 pulses per gallon. Display flow rate in tenths of a gallon per minute (XXXX.X).

$$RS = \frac{60 \times 10}{400} = 1.5000$$

(Select the XXXXX.X position on the rate decimal point menu.)

REAR TERMINAL DESCRIPTION

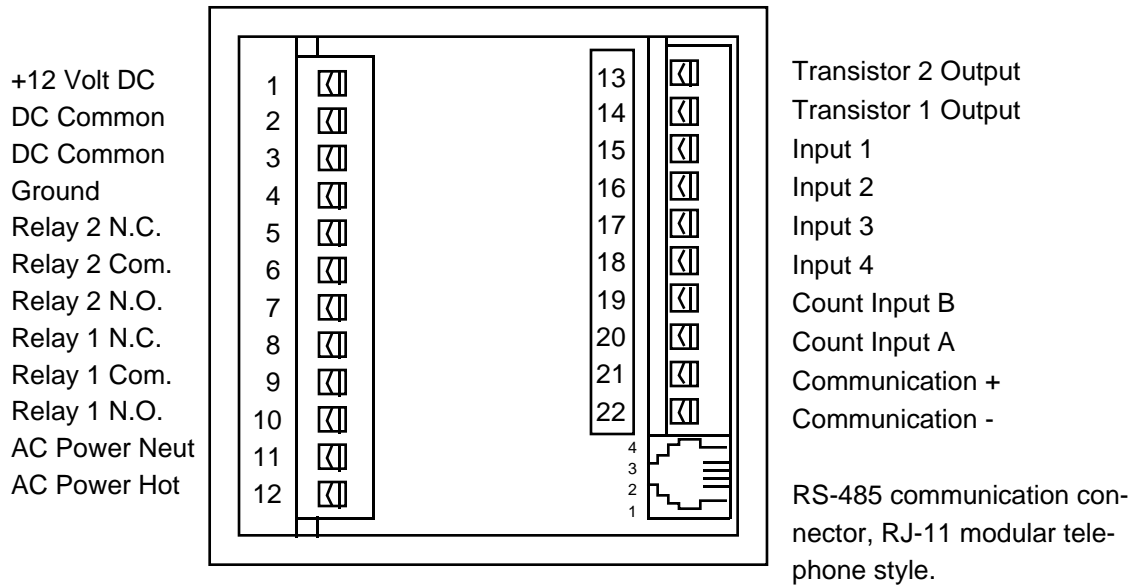

TERMINAL DESCRIPTIONS

1 - On models 57601 and 57602 this terminal is the +12 VDC power output. It is used to supply 12 VDC (+/- 25% 100 mA max) for accessories. DC Common is the negative side of this supply.

On the model 57600 this terminal is used for the 10-15 VDC power input. Connect the positive lead of the power supply to terminal 1 and the negative lead to DC Common.

The DC POWER OUTPUT contains a series Positive Temperature Coefficient (PTC) resistor that undergoes a large and abrupt increase in resistance when an over-current condition occurs. This resistance change limits the fault current to several milliamps. The PTC device will reset when the unit power has been removed for a time sufficient to cool the device. The overload condition should be removed before unit power is reapplied.

2, 3 and 4 - DC Common: These terminals are connected to the negative side of the counter's internal DC power supply. Count inputs must be referenced to DC Common. Control inputs are on when connected to DC Common. Transistor outputs conduct to DC Common when picked up. For maximum noise immunity, the ground terminal must be connected to a good earth ground. All shielded signal cables should be connected to earth ground or ground on the counter.

5, 6 and 7 - Relay 2 contacts

8, 9 and 10 - Relay 1 contacts

Each relay output consists of one electrically isolated form C set of contacts. The user must supply power through a contact to the external load. The contacts remain in the

normal state until a pickup signal occurs. The relay remains picked up (on) until a dropout signal occurs (see output programming diagram page 8 and block diagram page 2).

11 and 12 - AC Power Inputs:

Model 57601-404	115VAC
Model 57602-404	230VAC
Model 57600-404	Not used

13, 14 - Transistor Outputs 2 and 1: These terminals are separate open collector NPN transistor outputs. Each output conducts to DC Common when picked up (see output programming diagram page 8 and block diagram page 2).

15, 16, 17, and 18 - Inputs 1, 2, 3, and 4: Programmable inputs. The user can assign one of ten functions to each individual input. The inputs require a current sinking signal (contact or solid state) to DC Common (see input programming diagram page 7 and block diagram page 2).

19, 20 - Count Inputs B and A: Connect the count input signal(s) to these terminals. The count input can operate with either a current sinking signal (contact or solid state) to DC Common or a current sourcing signal. (See specifications, programming diagram page 6, and block diagram page 2.) Rate calculations are made from count pulses into Input A only.

21, 22 - RS-485 serial I/O port: Connect terminal 21 to the positive lead of the communications bus. Connect terminal 22 to the negative lead of the communications bus.

REAR TERMINAL DESCRIPTION CONTINUED

MODULAR COMMUNICATION JACK

The modular phone jack is an alternate connection to the RS-485 communications port. Pin 2 is positive and is the same as terminal 21. Pin 3 is negative and is the same as terminal 22. Pins 1 and 4 are connected to DC Common and should be used for any shield connections.

Note: This jack is intended only for connection to Ambassador and other RS-485 communication networks. **It should not be connected to any telephone system - damage or hazard may result.**



TERMINAL BLOCKS

Connections to the Ambassador are made through depluggable, screw terminal blocks to allow for ease of wiring and removal of the counter. The terminals can accommodate stranded, solid or fused wire (preferred) from 14 to 22 gauge.

To remove the terminal block, remove AC power and pry gently underneath each end of the terminal block with small screwdriver. Press straight on to re-install.

GENERAL WIRING PRACTICES

1.  Disconnect all power before wiring terminals. **A safety hazard exists if this precaution is not observed. Treat all control and count inputs as hazardous since they may carry line voltage.**
2. Use shielded cables for count signals, control input and communications signals. Connect shield to common (terminal 2, 3 or 4) of counter to terminate properly.
3. Keep all signal lines as short as possible.
4. Do NOT bundle or route signal lines with power or machine control wiring. Use separate conduit for power and signal wires.
5. Provide "clean" power to the counter. In severe cases, power may have to be filtered or a separate power source used. Do not use the same power source that is supplying the loads.
6. Use 18 ga. minimum (0.97mm², 600V) and 14 ga. maximum (2.1mm², 600V) wire for AC power wiring.
7. See page 26, top drawing, for the correct fuse to be used in the power input wiring.

DIP SWITCH FUNCTIONS

Switch 1: Input A sink/source
Off: input A requires a current sinking input signal.
On: input A requires a current sourcing input signal.

Switch 2: Input B sink/source
Off: input B requires a current sinking input signal.
On: input B requires a current sourcing input signal.

Switch 3: Input A threshold level
Off: high threshold level — use with DC sensors.
On: low threshold level — use with mag pickups. Turn switch 1 on.

Switch 4: Input B threshold level
Off: high threshold level — use with dc sensors.
On: low threshold level — use with mag pickups. Turn switch 2 on.

Dip switches may be set through an opening on the bottom of the unit. It is located towards the rear of the control.

PANEL MOUNTING

The panel mounting kit includes:
(1) mounting gasket, (2) mounting clips and (4) screws.

Refer to the dimension diagram on page 28 for a drawing of the correct installation of these parts.

The mounting gasket is coated on one side with a contact adhesive and a paper backing. Care should be taken during the gasket installation that the gasket be correctly positioned on the panel at the first attempt. Attempting to re-position the gasket once the adhesive has come in contact with the panel is likely to deform or tear the gasket. This may result in an improper seal. For best results, follow these directions:

1. Stand the Ambassador counter on a desk or table with its display down, screw terminals up.
2. Remove and discard the center square of the gasket at the scribe marks in the gasket and paper backing. Do not remove the backing from the remaining outer rim.
3. Slide the gasket down the unit until it is in position at the rear of the unit's front bezel. The paper backing side should be up.
4. Insert the tip of a knife between the paper and the gasket and, while holding the gasket down to the unit with the knife, peel off the paper backing.
5. Slide the unit through the panel cutout until the gasket firmly adheres to the panel.
6. Install the mounting clips and screws as shown in the diagram 28. Do not overtighten the mounting screws. The screws should be tight enough to firmly hold the unit in place, but not so tight as to squeeze the gasket out from behind the front bezel.
7. A switch shall be included in the building installation:
 - It shall be in close proximity to the equipment and within easy reach of the operator.
 - It shall be marked as the disconnecting device for the equipment.
 - Switches and circuit breakers in Europe must comply with IEC 947.

AC WIRING/CONTACT INPUT WIRING

AC Power Input

(AC Models Only)

Check part number on counter label to verify correct voltage rating.

57601-40X: 115 VAC
57602-40X: 230 VAC

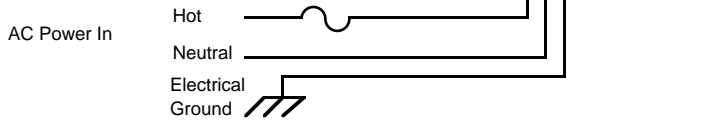

Terminal 4 (Ground) and terminals 2 and 3 (Com) are internally connected.

Fuse Size

AC Power In	U.S.	European
115 V, 60 Hz	1/8 amp	T125 mA, 250 V
115 V, 50 Hz	1/4 amp	T250 mA, 250 V
230 V, 60 Hz	1/16 amp	T60 mA, 250 V
230 V, 50 Hz	1/8 amp	T125 mA, 250 V

Use slow blow fuses for all voltages.

DC Power Input

(DC Models Only)

Check part number on counter label to verify correct voltage rating.

57600-40X: 10-15 VDC

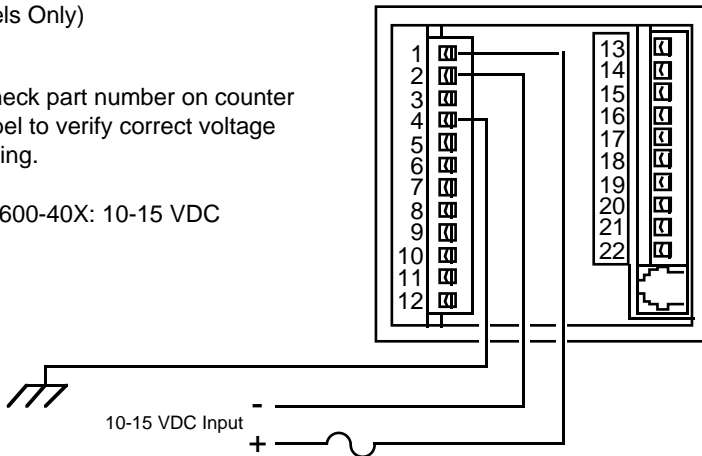

Terminal 4 (Ground) and terminals 2 and 3 (Com) are internally connected.

Use 1/2 amp slow blow fuse.
(Does not include external transducer load.)

Contact Count Input

To prevent multiple counts, use one of the contact count modes. See programming diagram.

All dip switches OFF.

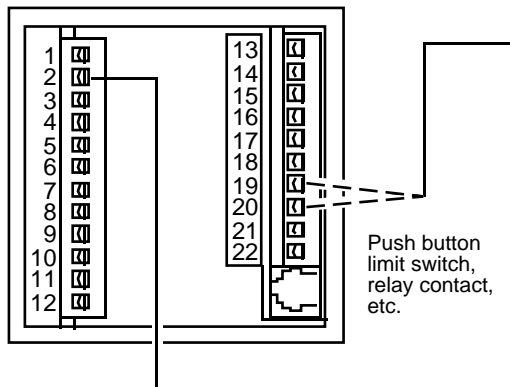

Dotted lines indicate which inputs may be wired in this manner. Typically a separate sensor is used for each input.

Control inputs (terminals 15-18) may be wired in the same manner.

COUNT INPUT WIRING

Current Sinking Sensor Count Input

Do not connect Term 1 if sensor is powered from another power supply.

Wire colors shown correspond to Cutler-Hammer inductive proximity and photo sensors.

All dip switches OFF.

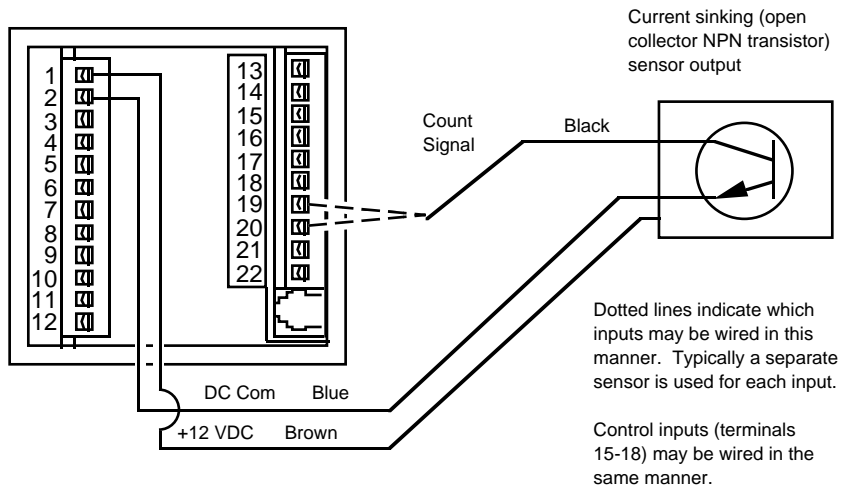

Current Sourcing Sensor Count Input

Do not connect Term 1 if sensor is powered from another power supply.

Wire colors shown correspond to Cutler-Hammer inductive proximity and photo sensors.

Dip switches 1 and/or 2 ON to select current source mode, switches 3 and 4 OFF.

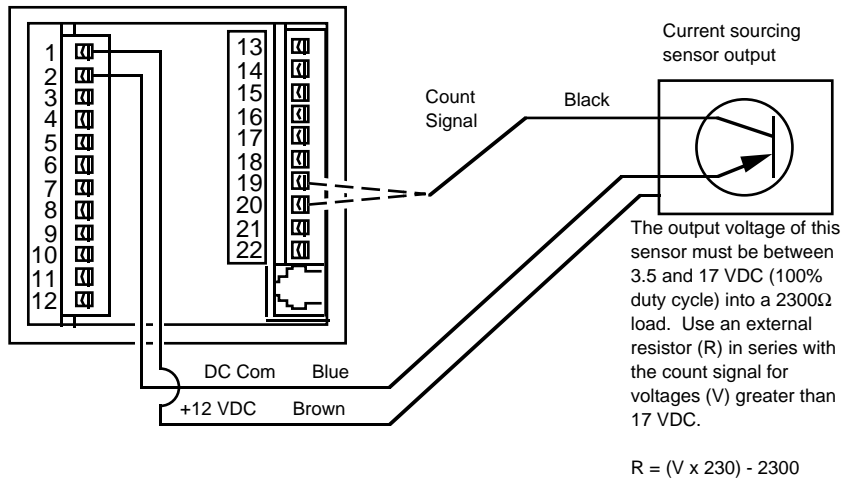

AC Signal Count Input

17 VAC RMS 48 V Peak-to-Peak maximum into 2.3 KΩ load impedance. Use an external resistor (R) in series with the count input signal for input voltages (V) greater than 17 VAC.

$$R = (V \times 230) - 2300$$

Dip switches 3 and/or 4 ON (AC mode).

Dip switches 1 and 2 ON.

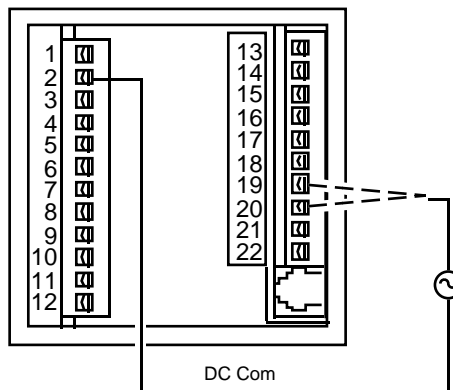

Caution:

The unit requires 1.2 V P-to-P minimum signal amplitude to count. Magnetic pickups produce an output voltage directly proportional to the speed of the ferrous material passing the pickup. At low speeds, or at starting or stopping, the output voltage from the pickup may not be great enough to cause the counter to count. For magnetic pickup signals in the range of 50 mV to 400 V P-to-P, a signal conditioner (Durant part no. 48160-400) is recommended.

ENCODER WIRING/OUTPUT WIRING

Shaft Encoder Wiring

Do not connect Term 1 if sensor is powered from another power supply.

Wire colors shown are for quadrature encoder, do not connect the yellow wire for a single channel encoder.

All dip switches OFF.

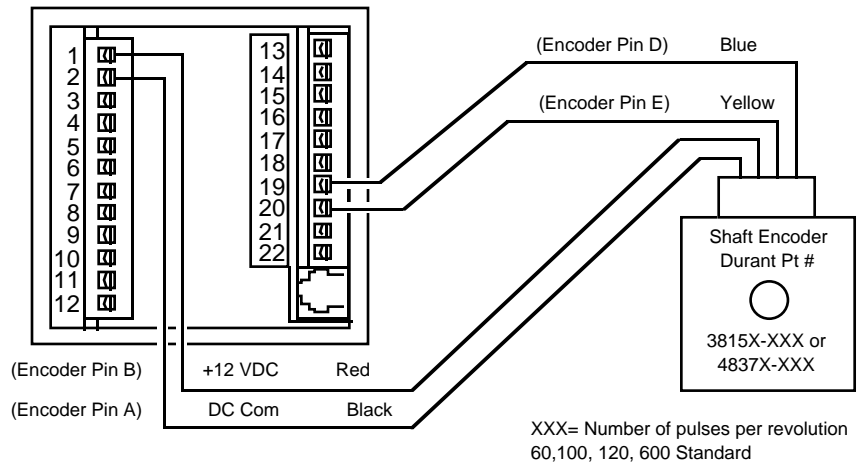

Relay Contact Output Wiring

This wiring example shows the load being controlled from the normally open contacts of Relay 1. Wiring for the normally closed contacts (8,9) would be done in the same manner. Wiring for the Relay 2 contacts (5,6,7) is also done in the same manner.

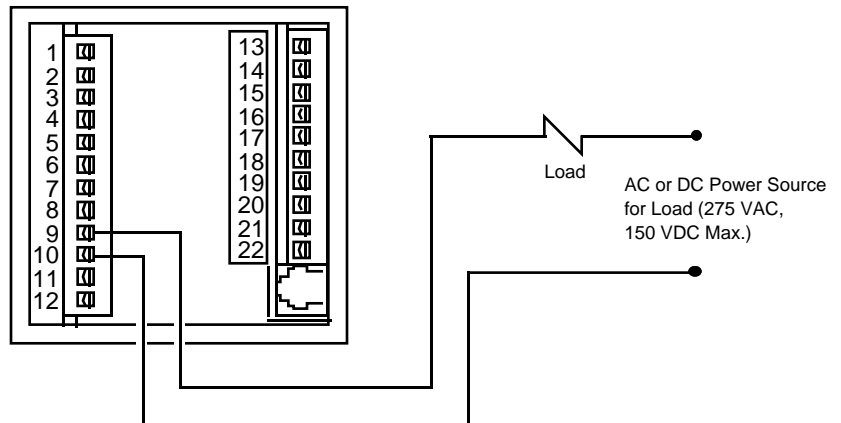

Wiring DC Loads to Transistor Outputs

- ① The load must not draw more than 200 mA of current.
- ② The counter's internal DC supply can be used to power DC loads. The total current drawn from terminal 1 cannot exceed 100 mA.
- ③ Use external diode suppression in parallel with inductive loads.

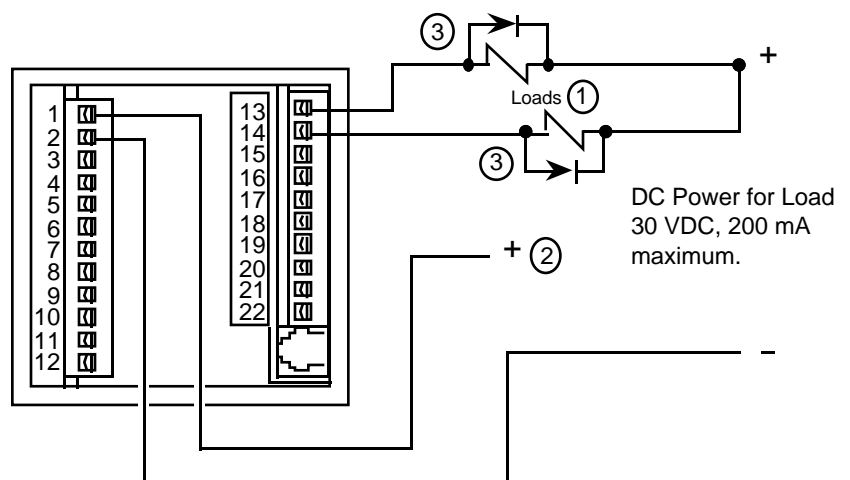

INTRODUCTION TO SERIAL COMMUNICATIONS

The advanced communication capability of the Ambassador control allows a host computer to read and reset counters, read and write presets, inhibit and enable counts, turn outputs on and off, lock and unlock the keyboard, and read and program all setup parameters.

The Control uses ASCII code with the RS-485 serial specification and Opto-22 compatible protocol. This allows bi-directional communications and addressing of multiple controls on a single two-wire communication bus. Each unit is individually addressed via a user programmable ID number. Up to 100 counters can be connected directly to the bus. Interconnect kits and bulk RS-485 communication cable are available; see accessory parts list.

Serial Command Summary

ESP: Enter Serial Programming	RST: Reset Totalizer
LAL: Lock All	STP: Stop Count
LPG: Lock Program	WP1: Write Preset 1
OCL: Output Control	WP2: Write Preset 2
RCD: Read Counter Data	WPB: Write Batch Preset
RDV: Read Device Value	WPI: Write Program Item
RPI: Read Program Item	UPG: Unlock Program
UAL: Unlock All	XSP: Exit Serial Programming
RSB: Reset Batch Counter	
RSC: Reset Counter	

SERIAL COMMAND FORMAT

The general command format is shown below. Spaces are used for clarity only and must not be transmitted.

> ID# COMMAND [numeric data] CHECKSUM (cr)

Example:

To cause unit# 10 to transmit the value of the main counter, send the RCD command as follows:

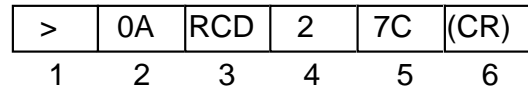

1. Message start character (ASCII 62). Required for all transmissions to the control.
2. Two digit serial port ID# in hexadecimal. Required for all transmissions to the control. Unit ID# 10 (decimal) is unit ID# 0A (hexadecimal). Capital letters must be used.
3. RCD (Read Counter Data) command. All serial commands consist of three characters. Letters may be upper or lower case (see pages 19 - 21 for description of all commands).

Example of an Ambassador Serial Communication Network

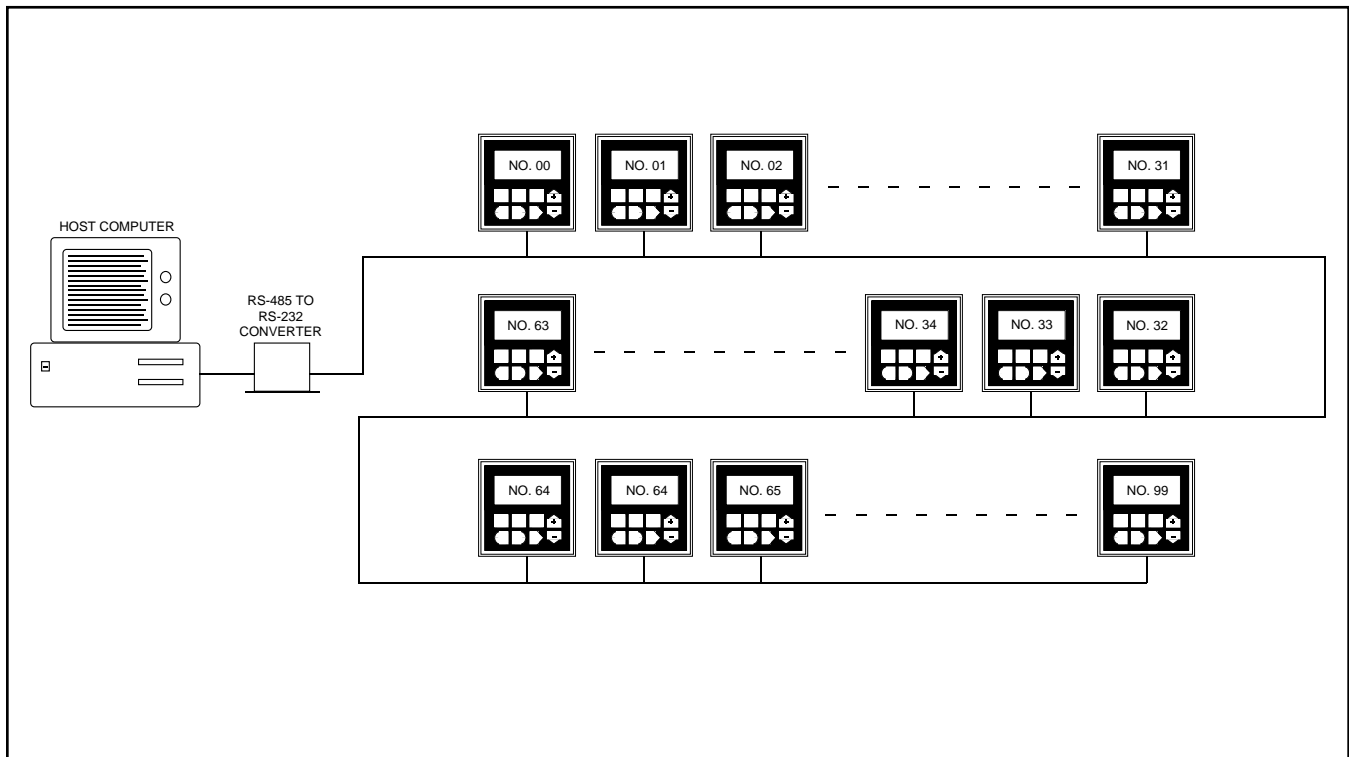

SERIAL COMMAND/RESPONSE FORMAT

- Numeric data required with the RCD command to specify counter or preset to be read. Up to eight numeric characters are required for some commands. Most commands do not require any numeric characters (see pages 19 through 21 for list of all commands).
- Two digit hexadecimal checksum of the ASCII values of the ID number, command, and any required numeric characters. Required for all transmissions to the control.

Checksum Calculation:

0	A	R	C	D	2
---	---	---	---	---	---

$$48 + 65 + 82 + 67 + 68 + 50 = 380 \text{ (dec.)}$$

The checksum is the last two hexadecimal characters — 7A. Upper or lower case letters may be used. The > start character and carriage return are not used in calculation.

- ASCII carriage return (13 decimal). Required at the end of all commands.

SERIAL RESPONSE FORMAT

The counter does not respond to a command unless the transmitted ID number matches its programmed ID number.

If the ID numbers match and the command and checksum are valid, the control executes the command and transmits a response as shown below:

A [data] [checksum] (cr) where:

A is the acknowledge character (ASCII 65) sent when any valid command is received and executed.

[data] is sent in response to the RCD, RDV, or RPI commands which request data. Data is not transmitted for other commands.

[checksum] is sent only when data is requested (RCD, RDV or RPI commands). The checksum is calculated by adding the ASCII values of all preceding characters (including the spaces except the acknowledge character "A"). The checksum is the two least significant digits of this sum in hexadecimal.

(cr) is the ASCII carriage return (13 decimal). Transmitted at the end of all responses.

EXAMPLES:

A(cr)	No data requested
ACT 337914 52(cr)	Count data requested

If the ID numbers match but the command is not valid or cannot be executed, the counter ignores the command and

responds by sending an ASCII "N" (not acknowledged) followed by a two character error code and a carriage return.

Error Codes:

- 00 - Power up Error — When power is applied to the unit, or the program mode is exited, the unit performs a power up self test. The first valid command received by the unit following the self test is not executed and not acknowledged.
- 10 - Lock input is on — cannot change preset values or enter serial program mode until lock input is removed.
- 02 - Checksum error — received checksum does not match calculated checksum.
- 01 - Command not found in table or invalid command — WPI, RPI, XSP received when not in serial program mode.
- 05 - Invalid data — incorrect number of digits or illegal character received in data field.
- 11 - Preset edit in progress on keyboard — serial preset cannot be sent if preset is being changed on the keyboard.
- 12 - Command is valid for this family but not this counter or command is not valid with this program configuration — cannot change output time if output is set to latch.
- 13 - Keyboard programming mode is active — cannot enter serial program mode if in keyboard program mode.

EXAMPLES: N05(cr) Invalid data
N10(cr) Lock input is on

SERIAL RUN-MODE COMMANDS

RCD(n) — Read Counter Data

This command must be followed by a number (n) from 0 to 7. The number determines which value the counter sends. The requested value is preceded by a two character counter or preset abbreviation. The counter formats its response in a 12 character field. The counter sends any programmed decimal points in the correct location. Leading zeros are sent as spaces.

EXAMPLE COMMAND: >1BRCD37F(cr) Reads rate indicator from unit 27.

EXAMPLE RESPONSES:

(n)	Value Sent	Response Formats with Different Decimal Points
0	Main counter	ACT 123456 4C(cr)
1	Batch counter	ABT 123456 4B(cr)
2	Totalizer	AT 12345678 58(cr)
3	Rate	ART 123456 5B(cr)
4	Preset 1	AP1 123456 36(cr)
5	Preset 2	AP2 123456 37(cr)
6	Batch Preset	APB 123456 47(cr)

SERIAL COMMANDS

0	Main counter	ACT	123.456	5A	(cr)
1	Batch counter	ABT	123456	4B	(cr)
2	Totalizer	AT	12345.678	66	(cr)
3	Rate	ART	123.456	69	(cr)
4	Preset 1	AP1	123.456	44	(cr)
5	Preset 2	AP2	123.456	45	(cr)
6	Batch Preset	APB	123456	47	(cr)

RCD7 is a special command that sends all of the values that have been specified in the SERIAL OUTPUT menu. The counter sends values in the order shown above. If the counter is programmed to send the main count, batch count, preset 1, and preset 2, the response might look like this:

```
ACT 123.456 BT 0 P1 123.456 P2 123.456 C9(cr)
```

WP1(nnnnnn) — Write Preset 1
WP2(nnnnnn) — Write Preset 2
WPB(nnnnnn) — Write Batch Preset

The write preset commands allow a host computer to enter new preset values. The command must be followed by a 6 digit number (000000 to 999999). All leading zeros must be supplied. As with keyboard entry, decimal points cannot be sent to the counter. The counter always displays any decimal point in the programmed position.

EXAMPLE: >10WP10005005E(cr) Sets preset 1 to a value of 500 on unit 16.

RSC -- Reset Counter
RSB -- Reset Batch Counter
RST -- Reset Totalizer

The serial reset commands work the same as the reset key (edge) and reset input (edge) functions. Any outputs which are programmed to pickup or dropout with a counter reset signal will also respond to the RSC command.

EXAMPLE: >00RSC48(cr) Resets the main counter on unit 00.

LAL — Lock All
LPG — Lock Program
UAL — Unlock All
UPG — Unlock Program

The lock and unlock commands allow a host computer to lock or unlock keyboard programming. The commands are similar to a lock input function except serial write and programming commands (WP1, WP2, WPB, and ESP) are still allowed.

The counter does not store lock commands when power is removed. The host must re-issue the desired lock command after power is re-applied.

Lock inputs are not affected by serial lock commands. If both a lock input and a serial lock command are in effect, the user must remove both locks before programming from the keyboard. The user only needs to remove the lock input for serial programming.

EXAMPLE: >5AUPG62(cr) Cancels a previously issued Lock Program command to unit 90.

STP — Stop Count
RSM — Resume Count

These commands mimic the stop count input function. When the counter receives an STP command, all count input pulses are ignored until the counter receives an RSM command. These commands are useful when synchronizing serial counter reset commands.

The counter does not store the serial stop command when power is removed. The unit will count input pulses when power is re-applied.

EXAMPLE: >00STP57(cr) Inhibit counts on unit 00
>00RSC48(cr) Reset main counter on unit 00
>00RST59(cr) Reset totalizer on unit 00
>00RSM52(cr) Resume counting on unit 00

OCL — Output Control

Any outputs programmed to pickup or dropout with an output control signal will respond. This command is a one-shot or edge command. It is the same as turning on an input that has been programmed for output control.

EXAMPLE: >01OCL3F(cr) Sends an output control signal to unit 01.

RDV — Read Device Value

This command causes the counter to respond with the product family number, the software version number, the hardware configuration byte, and the serial ID number.

EXAMPLE COMMAND: >00RDV4C(cr) Sends RDV command to unit 00.

For this counter the family number is "1", the software version is "1" or greater, and the hardware configuration byte is "DF". If the serial ID is set to 99 (63 hexadecimal), the response to the RDV command will be:

EXAMPLE RESPONSE: A11DF6355(cr)

SERIAL COMMUNICATIONS

SERIAL PROGRAM-MODE COMMANDS

ESP — Enter Serial Programming

This command causes the counter to enter the serial programming mode. The host must send this command before the unit will respond to serial programming commands (WPI, RPI, and XSP). The counter displays the message "LOADING PROGRAM" when it receives a valid ESP command. The counter and preset values are saved and the outputs dropout as when entering the keyboard programming mode.

If the counter is in the serial programming mode and power is removed, it will enter the keyboard programming mode when power is re-applied.

EXAMPLE: >00ESP48(cr) Causes unit 00 to enter the serial programming mode.

XSP — Exit Serial Programming

This command causes the counter to store any new program data and exit the serial programming mode. It is similar to exiting the keyboard programming mode.

EXAMPLE: >00XSP5B(cr) Causes unit 00 to exit serial programming.

WPI(nnn - nnnnnnnn) — Write Program Item

This command allows a host computer to remotely program an Ambassador unit. The unit must be in the serial programming mode (ESP command). The host must send the WPI command followed by the two to four digit edit menu number of the desired function. A one to six digit data value is required with some edit menus (see diagram on pages 22 and 23 for edit menu item numbers).

EXAMPLE: >00WPI02360000DB(cr) Sets the rate scaler to 60.000 on unit 00.

RPI(nn - nnn) — Read Program Item

This command allows a host computer to determine the programming of an Ambassador unit. The unit must be in the serial programming mode (ESP command). The host must send the RPI command followed by a two or three digit number representing the desired sub-menu (see diagram on pages 22 and 23 for sub-menu numbers). The counter responds by transmitting a number representing the current option selected for a sub-menu.

EXAMPLE COMMAND: >00RPI20AD(cr) Read input 1 selection.

EXAMPLE RESPONSE: A20092(cr) Input 1 is disabled.

SAMPLE COMMUNICATIONS PROGRAM

The following BASIC program can be used to demonstrate the serial communications capability of the Ambassador controls. The program requires the user to enter an Ambassador command with the correct unit ID# and format (example: 00WP1123456). The program will calculate the checksum and include it in the command string along with the preceding ">" character. The command string will then be printed to the screen and sent to the Ambassador unit (example: >00WP11234566E). The program then prints the Ambassador response to the screen (example: A).

Note: This sample program is intended for illustration purposes only and is not guaranteed to work with all computers and BASIC compilers or interpreters.

```
100 REM **** INITIALIZE AND INPUT ****
110 DEFINT A - Z
120 DEF SEG = &H40
130 CB = PEEK(1) * &H100 + PEEK(0)
135 DEF SEG
140 MSR = CB + 6
150 LSR = CB + 5
160 MCR = CB + 4
170 RTSON = 8 + 2 + 1 : RTSOFF = 8 + 1
180 OPEN "COM1:19200,N,8,1,RS" AS #1
190 ON TIMER(1) GOSUB 450
200 INPUT "ENTER COMMAND > ", A$
210 REM **** CALCULATE CHECKSUM ****
220 CS = 0
230 R$ = ""
240 FOR X = 1 TO LEN(A$)
250 CS = CS + ASC(MID$(A$, X, 1))
260 NEXT X
270 CS = CS AND 255
280 CS$ = HEX$(CS)
290 IF CS < 16 THEN CS$ = "0" + CS$
300 T$ = ">" + A$ + CS$ : PRINT T$
310 REM **** RTS CONTROL AND SEND ****
320 OUT MCR, RTSON
330 PRINT #1, T$
340 IF INP(LSR) <> &H60 THEN 340
350 OUT MCR, RTSOFF
360 REM ***** GET RESPONSE *****
370 TIMER ON
380 IF LOC(1) = 0 THEN 380
390 R$ = R$ + INPUT$(LOC(1), #1)
400 TIMER OFF
410 IF RIGHT$(R$, 1) <> CHR$(13) THEN 370
420 PRINT R$
430 GOTO 200
440 REM **** NO RESPONSE ROUTINE ****
450 PRINT "NO RESPONSE" : PRINT
460 TIMER OFF : RETURN 200
```

SERIAL PROGRAMMING

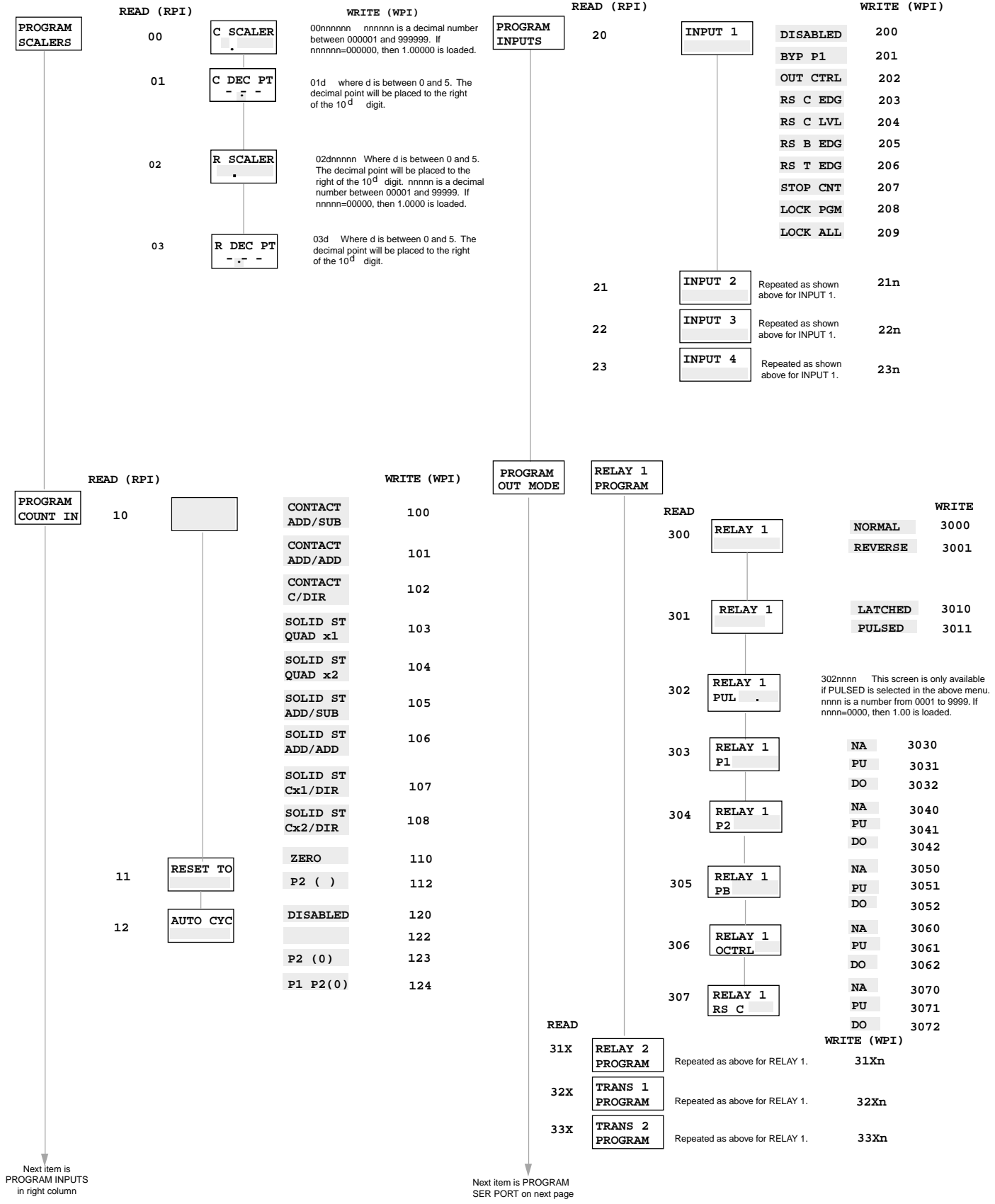

SERIAL PROGRAMMING

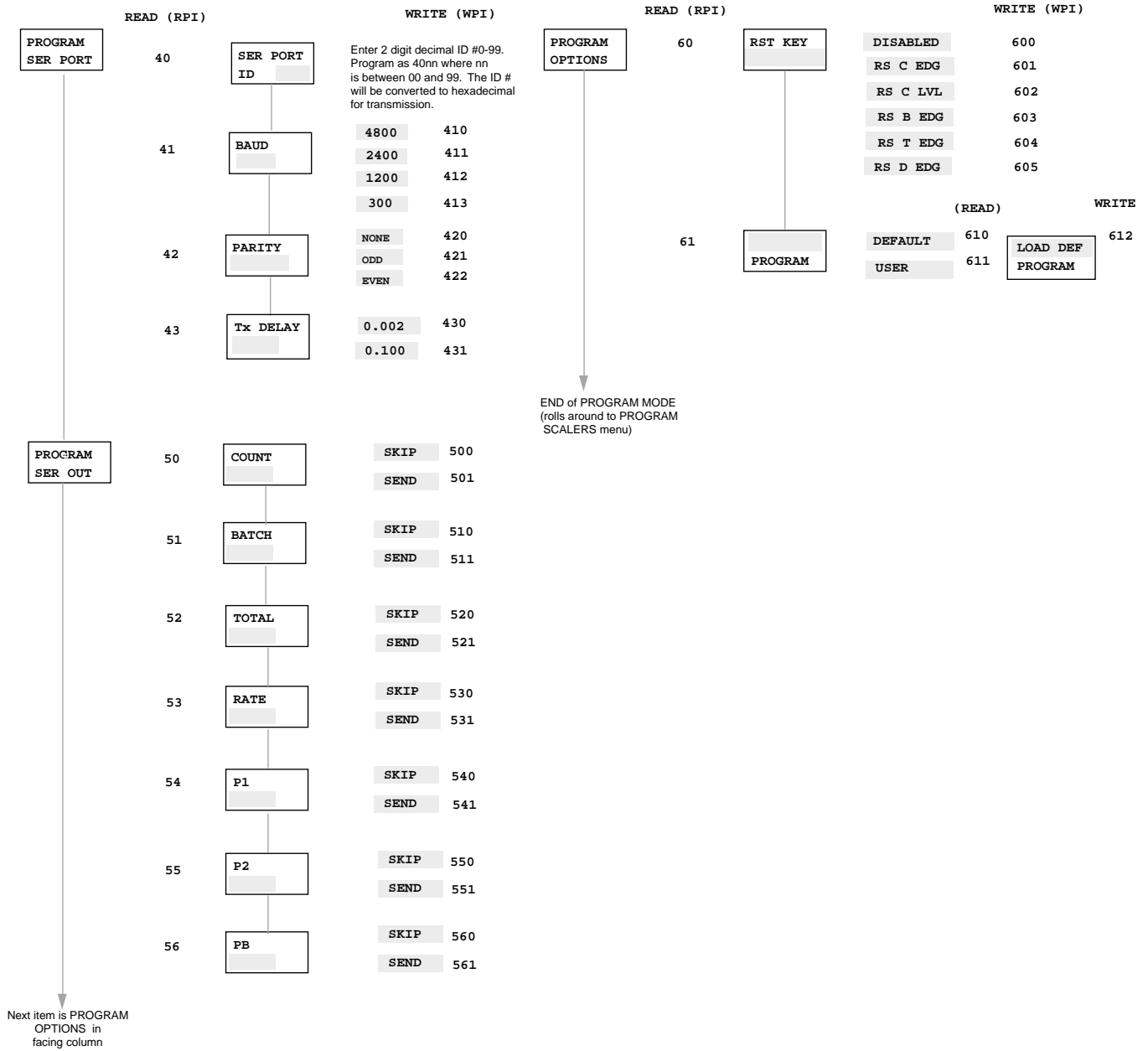

TROUBLESHOOTING

SELF-TEST ROUTINES

The 5760X-404 counter has several built in self-test routines. The counter performs these tests each time power is applied. If questionable operation ever occurs, run the self-test routines by removing and re-applying power to the unit.

If one of the internal test routines discovers a problem, the counter displays the message "ERROR X" where X is a single digit test number. The counter will not operate when displaying an error code. All outputs will remain in the off (dropped-out) state. In the error mode, the counter responds to all serial commands with a "N" followed by the failed test number.

Description of tests

- #0 - ROM (Read Only Memory) Test: This routine checks that the ROM which holds the counter's operating program, is not corrupted.
- #1 - RAM (Random Access Memory) Test: This routine checks the read / write memory used by the counter for normal operation and communication.
- #2 - Display Test: This routine checks the operation of the display driver.
- #3 - Non-Volatile RAM Test #1: This routine checks the run data section of NOVRAM. This NOVRAM section retains all count and preset values while power is removed.
- #4 - Non-Volatile RAM Test #2: This routine checks the user program section of the NOVRAM. This section retains all programmable options and parameters while power is removed.
- #5 - Non-Volatile RAM Test #3: This routine checks the integrity of the NOVRAM.

What to do when a test fails

1. Immediately halt the machine or process being controlled by the counter. Record the displayed error number.
2. If the counter shows ERROR 0, 1, 2, or 5, run the self-tests again by removing and re-applying power to the counter.

If the counter shows ERROR 3, press the front panel reset key. This will set all counters and preset values to zero and rerun all tests.

If the counter shows ERROR 4, press the front panel reset key. This will reset all user programmable options to the factory default settings and rerun all tests.

3. If the same error occurs again there is a malfunction within the counter — return it to the factory for repair.

If the counter does not display an error, the unit is OK and can be put back in service. Before starting the machine again, check all preset values and user programmable options to insure that these parameters have not changed. A serious safety hazard could result if the operating characteristics of the counter have changed.

TROUBLESHOOTING

Some of the troubleshooting steps which follow require the user to change the programming of the unit.



Be sure to restore all programmable options to their required settings before running any machinery with the counter.

I. Display is Blank:

- A. Check that incoming power is wired correctly. Connect a voltmeter to the power input terminals and verify that the correct voltage is being supplied to the counter.
- B. Remove and restore power to the counter. If this corrects the problem, investigate the following causes:
 1. Counter NOT properly grounded - check that terminal 4 is connected to a good electrical ground.
 2. Electrical noise spike from inductive loads - install R-C suppressors in parallel with any external solenoid or relay coils that the counter controls.
 3. Electrical noise spikes in power supplied to the counter - run power to counter from another source or install a power line filter.

II. Counter Will Not Count:

- A. Check the count scale factor and verify that it is set to the correct value. Set the scale factor to 1.00000 and try counting again before proceeding any further with troubleshooting.
- B. Test Counter using a manual count source.
 1. Remove any wires connected to terminals 19 and 20.
 2. Turn all dip switches off.
 3. Reset all program parameters to the factory default settings (enter the program mode and select the PROGRAM OPTIONS menu, select the USER PROGRAM sub-menu, select the LOAD DEF PROGRAM selection and press ENT).

TROUBLESHOOTING

4. Make and break a connection between terminals 4 and 20 using a jumper wire. The main counter and totalizer should count up each time the connection makes. If the counters do not count, send the unit to the factory for repair.
 5. Make and break a connection between terminals 4 and 19 using a jumper wire. The main counter and totalizer should count down each time the connection makes. If the counters do not count, send the unit to the factory for repair.
- C. If the counter counted from the manual count source in step B above, reconnect the sensor and select the correct dip switch setting. For sensors with a DC pulse output, perform steps 1 and 2. For magnetic pickup sensors, proceed to step 3 below.
1. With the sensor output in the high state, measure the voltage between DC Common and the count input. The voltage must be greater than 3.5 VDC. If it is lower, the sensor is defective, leaky, or is not compatible with the counter. With current sinking sensors, try adding a pull-up resistor (470 ohms to 4700 ohms) from terminal 1 to the count input. Note: for AC powered counters, the maximum current out of terminal 1 must not exceed 100 mA.
 2. With the sensor output in the low state, measure the voltage between DC Common and the count input. The voltage must be less than 1.9 VDC. If it is higher, the sensor is defective, leaky, or is not compatible with the counter. With current sourcing sensors, try adding a pull-down resistor (220 to 2200 ohms) from the count input to DC Common.

Note: for AC powered counters, the maximum current out of terminal 1 must not exceed 100 mA.
 3. For magnetic pickup sensors, measure the AC voltage output of the sensor with the machine running. The output voltage should be greater than 0.45 volts RMS (1.2 volts peak to peak). If it is less, the sensor is defective, or the target is too far from the sensor, or the target is not moving fast enough.

III. Error Message On Display:

The message "ERROR" followed by a single digit number on the display indicates that the counter's internal self-tests have detected a problem. See the self-test section of this manual (page 24) to determine what caused the problem and how to solve it.

IV. Other Problems:

Other problems are usually caused by programming and/or wiring errors. Because of the versatility of this counter, it is

impossible to include troubleshooting instructions for every situation that could arise. However, the following general troubleshooting steps should help in resolving specific problems:

1. Define, in detail, exactly what the problem is and when it occurs.
2. Use the block diagram and/or the menu programming diagram to determine which program options or parameters are related to the problem. Check their setting.
3. Determine which I/O circuits are related to the problem and check their operation with a voltmeter at the counter's terminal strips.

If going through the above 3 steps did not lead you to a solution, perform the following:

1. Record the wiring connections to each terminal on the unit.
2. Place the unit in the run mode and press the help key. Write down the 4 lines of data. The Ambassador help screens are provided as an alternate method of determining a unit's programming. The two help screens contain 32 characters of information. Pressing the HELP/* key displays screen 1. The characters are arranged as shown below:

1	2	3	4	5	6	7	8
9	10	11	12	13	14	15	16

Help Screen Character Numbers - Screen 1

Press the down arrow key to display screen 2.

17	18	19	20	21	22	23	24
25	26	27	28	29	30	31	32

Help Screen Character Numbers - Screen 2

3. Call the Durant application help line (800-334-4357) and ask for an application engineer to assist you with troubleshooting.

SPECIFICATIONS

POWER INPUT:

AC Operation: 115 VAC (+/-15%) std., 50 to 60 Hz, 7 W
 230 VAC (+/-15%) opt., 50 to 60 Hz, 7 W
 DC Operation: 10 to 15 VDC opt., 300 mA maximum

DC POWER OUTPUT:

12 VDC (+/-25%), 100 mA maximum (includes all line and load variations)

ENVIRONMENT:

Operating Temperature: 32 to 131°F (0 to 55°C)
 Storage Temperature: -4 to 158°F (-20 to 70°C)
 Operating Humidity: 85% Relative, non-condensing
 NEMA 4 rating when mounted with gasket provided

PHYSICAL:

Case Dimensions: 2.64" (67mm) W x 2.64" (67mm) H
 x 5.60" (142mm) D
 Bezel Dimensions: 2.95" (75mm) W x 2.95" (75mm) H
 Panel Cut-out: 2.68" (68mm) W x 2.68" (68mm) H
 Weight: 1.2 lbs. (0.54 kg.)
 Display Size: 2 x 8 characters, 0.30" high
 Display Color: Green backlit LCD and reverse-image red LCD.

MAIN COUNTER:

Type: Bi-directional
 Digits: 6
 Presets: 2
 Reset modes: Auto or manual reset to zero or preset
 Scaler Range: 0.00001 to 9.99999
 Decimal Point: 5 positions, programmable
 Output Latency: 0.7 to 2.7 mS

BATCH COUNTER:

Type: Increment with main counter recycle or preset 2 signal
 Digits: 6
 Presets: 1
 Output Latency: 0.7 to 2.7 mS

TOTALIZER:

Type: Bi-directional, same or opposite of main counter
 Digits: 8
 Scaler: Shared with main counter
 Decimal Point: Tracks main counter

COUNT SPEEDS:

The maximum count speed depends on the selected count mode. All maximum speeds are shown with square wave (50% duty cycle) input.

Mode (Inp A/Inp B)	Maximum Speed	
	Solid state (high speed)	Contact (low speed)
Add/Sub	20 kHz	40 Hz
Add/Add	20 kHz	40 Hz
Count/Direction	15 kHz	40 Hz
Count x 2/Direction	7.5 kHz	N/A
Quadrature	6.5 kHz	N/A
Quadrature x 2	6.5 kHz	N/A

COUNT INPUTS:

Sink: Impedance: 4.6k ohms to +5 VDC
 Voltage: high 3.5 to 34.0, low 0.0 to 1.9 VDC
 Source (high): Impedance: 2.3k ohms to common
 Voltage: high 3.5 to 17.0 VDC (100% duty cycle), low 0.0 to 1.9 VDC
 Source (low): Impedance: 2.3k ohms to common
 DC Voltage: high 0.6 to 17.0 VDC, low -17.0 to -0.6 VDC
 AC Voltage: 17 VAC~ (48 V Peak-Peak) maximum

CONTROL INPUTS:

Impedance: 4.7k ohms to +5 VDC
 Voltage: High +3.7 to +24 VDC, Low 0.0 to .9 VDC
 Response: Minimum low 15 ms, minimum high 15 ms.

RELAY OUTPUTS (2):

Type: SPDT contacts
 U.L Ratings: 250 VAC, 360 VA Pilot Duty.

TRANSISTOR OUTPUTS (2):

Type: NPN open collector with transient protection
 Maximum Voltage (off state): 30 VDC
 Maximum Current (on state): 200 mA @ 1.3 VDC

COMMUNICATION:

Type: RS-485
 Format: 1 start bit, 7 data bits (ASCII), 1 parity bit, 1 stop bit
 Protocol: Opto-22 compatible
 Speed: 300, 1200, 2400, 4800, 9600 and 19200 baud
 Parity: Odd, Even, None (space transmitted, ignore received)

COUNT ACCURACY:

100% when counter is operated within the specified count speeds and count signal high and low times.

RATE INDICATOR:

Type: 1/Tau
 Digits: 6
 Scaler range: 0.00001 to 99999
 Decimal point: 5 positions, programmable
 Accuracy: +/-0.015% of reading
 Update Time: 1 second, fixed
 Zero Time: 10 seconds, fixed

CONNECTIONS:

Type: Dual depluggable screw terminal strips
 Conductor Size: 14 - 22 AWG (2.1mm² - 0.38mm²), 600V, solid, stranded, or fused (preferred)

PARTS / ACCESSORIES

Spare Parts

36172-202	Front Panel Gasket
48369-200	Mounting Clip
28748-200	Screw for Mounting Clip
48355-110	Terminal Strip - 10 Position
48355-112	Terminal Strip - 12 Position

Ambassador Family Accessories

48183-401	Desk Mount Kit (enclosure for flat surface mounting)
58801-460	RS-485 to RS-232 Communications Converter
58801-461	RS-485 to RS-232 Communications Converter (Europe)
38145-400	RS-485 Interconnect Kit
38146-xxxx	RS-485 Cable - xxxx is length in feet, specify with 4 digits (0500 = 500 ft)

General Accessories

48160-400	Input Signal Conditioner
48160-440	Timer Module (selectable time base oscillator)
48160-45x	Analog to Frequency Converter
49990-4xx	Simultaneous Input Processor (anti-coincidence counting from multiple input devices)
38091-400	RC Surge Suppressor
36059-45x	Solid State I/O Modules (AC Input and Output, DC Input and Output)

Transducers

38150-xxxx	Medium Duty, single channel Shaft Encoder
38151-xxxx	Medium Duty, quadrature Shaft Encoder
48370-xxxx	Heavy Duty, single channel Shaft Encoder
48371-xxxx	Heavy Duty, quadrature Shaft Encoder
ES9513-RS	Rotary Contactor
39400-400	Zero Speed Vane Pickup
47004-400	Magnetic Pickup
28433-400	30 Tooth Gear for Magnetic Pickup

Ambassador Family Count/Controls

5760x-400	Totalizer with Rate - green display
5760x-401	Single Preset with Rate - green display
5760x-402	Single Preset with Rate, Batch & Totalizer - green display
5760x-403	Dual Preset with Rate - green display
5760x-404	Dual Preset with Rate, Batch & Totalizer - green display
5760x-405	Four Preset with Rate, Batch & Totalizer - green display
5760x-415	Feet/Inches Control - green display
5760x-450	Totalizer with Rate - red display
5760x-451	Single Preset with Rate - red display
5760x-452	Single Preset with Rate, Batch & Totalizer - red display
5760x-453	Dual Preset with Rate - red display
5760x-454	Dual Preset with Rate, Batch & Totalizer - red display
5760x-455	Four Preset with Rate, Batch & Totalizer - red display
5760x-465	Feet/Inches Control - red display

OVERALL DIMENSIONS

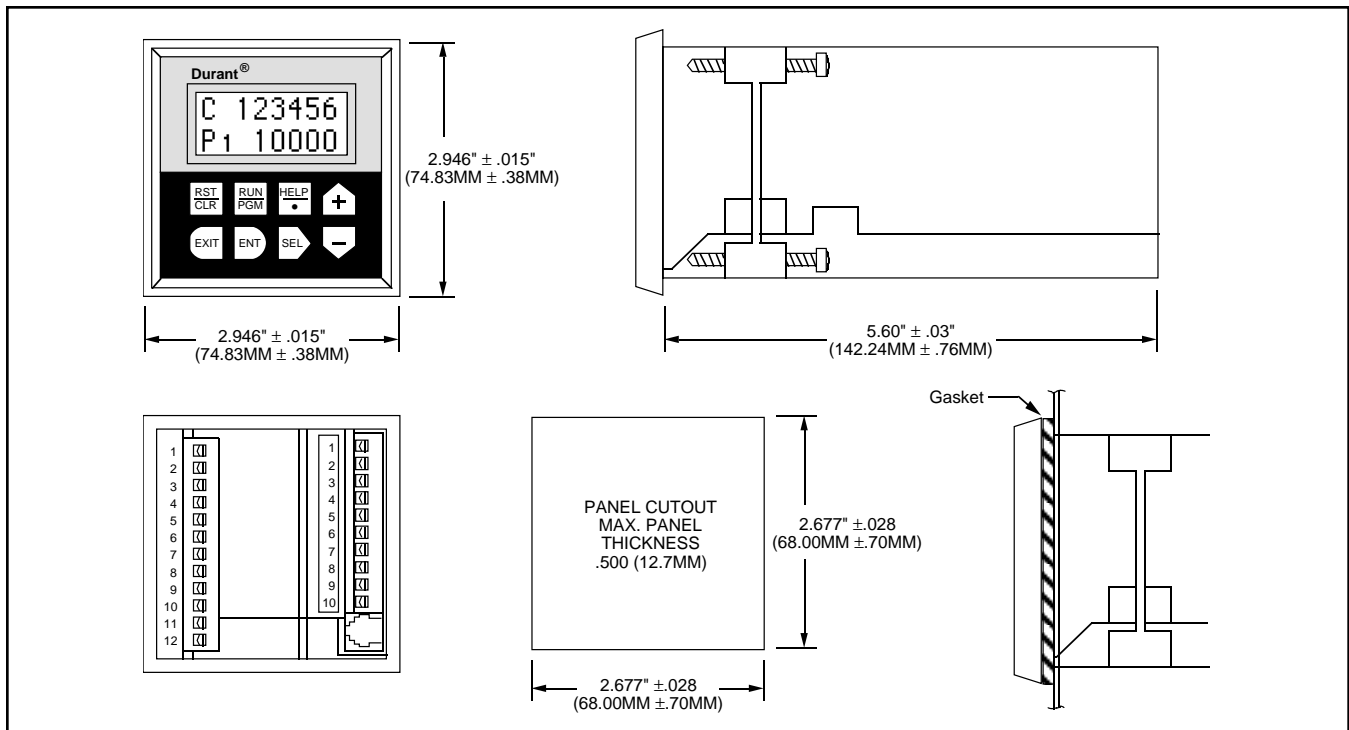

WARRANTY: Eaton warrants all products against defects in material and workmanship for a period of one (1) year from the date of shipment to Buyer. This is a limited warranty limited to its terms. This warranty is void if the product has been altered, misused, taken apart or otherwise abused. ALL OTHER WARRANTIES, EXPRESS OR IMPLIED, ARE EXCLUDED, INCLUDING BUT NOT LIMITED TO THE IMPLIED WARRANTIES OF MERCHANTABILITY AND FITNESS FOR PURPOSE.

BUYERS' REMEDIES: Eaton's obligations and liabilities under the foregoing warranty are limited to repair or replacement of the product without charge. To receive the required Return Goods Authorization number (RGA), contact your local Durant distributor or Durant Repair Department at 800-540-9242. A charge is made for repairing after the expiration of the warranty. IN NO EVENT SHALL EATON BE LIABLE FOR CLAIMS BASED UPON BREACH OF EXPRESS OR IMPLIED WARRANTY OR NEGLIGENCE OR ANY OTHER DAMAGES WHETHER DIRECT, IMMEDIATE, FORESEEABLE, CONSEQUENTIAL OR SPECIAL OR FOR ANY EXPENSES INCURRED BY REASON OF THE USE OR MISUSE, SALE OR FABRICATION OF PRODUCTS WHICH DO OR DO NOT CONFORM TO THE TERMS AND CONDITIONS OF THIS CONTRACT.

INDEMNIFICATION: Buyer agrees to hold Eaton harmless from, defend, and indemnify Eaton against damages, claims and expenses arising out of subsequent sales of Durant products or products containing components manufactured by Eaton and based upon personal injuries, deaths, property damage, lost profits, and other matters for which Buyer, its employees or sub-contractors are or may be to any extent liable, including without limitation penalties imposed by the Consumer Product Safety Act (P.L.92-573) and liability imposed upon any person pursuant to the Magnuson-Moss Warranty Act (P.L.93.637), as now in effect or as amended hereafter. The warranties and remedies provided for herein are available to Buyer and shall not extend to any other person.

COMPLIANCE WITH OSHA: Eaton offers no warranty and makes no representation that its products comply with the provisions or standards of the Occupational Safety and Health Act of 1970, or any regulations issued thereunder. In no event shall Eaton be liable for any loss, damages, fines, penalty or expense arising under said ACT.

This manual constitutes proprietary information of Eaton Corp., and is furnished for the customers' use in operating the Ambassador Series Count Control. Reproduction of this material for purposes other than the support of the Ambassador Series Control or related products is prohibited without the prior written consent of Eaton Corp., Watertown, WI.

In the construction of the Control described herein, the full intent of the specifications will be met. Eaton Corp., however reserves the right to make, from time to time and without proper written notice, such departures from the detail specifications as may be required to permit improvements in the design of the product.

The information included herein is believed to be accurate and reliable, however no responsibility is assumed by Eaton Corp., for its use; nor for any infringements of patents or other rights of third parties which may result from its use.

This equipment is capable of generating radio frequency energy. If not installed and used in accordance with the instructions, this unit may interfere with radio communications.

Printed in U.S.A.

Durant
901 South 12th Street
Watertown, WI 53094
920-261-4070 • 1-800-540-9242 • FAX 920-261-9097