

Keysight Technologies

DSOX3PWR/DSOX4PWR/DSOX6PWR Power Measurement Options

Data Sheet

For InfiniiVision 3000, 4000 and
6000 X-Series Oscilloscopes

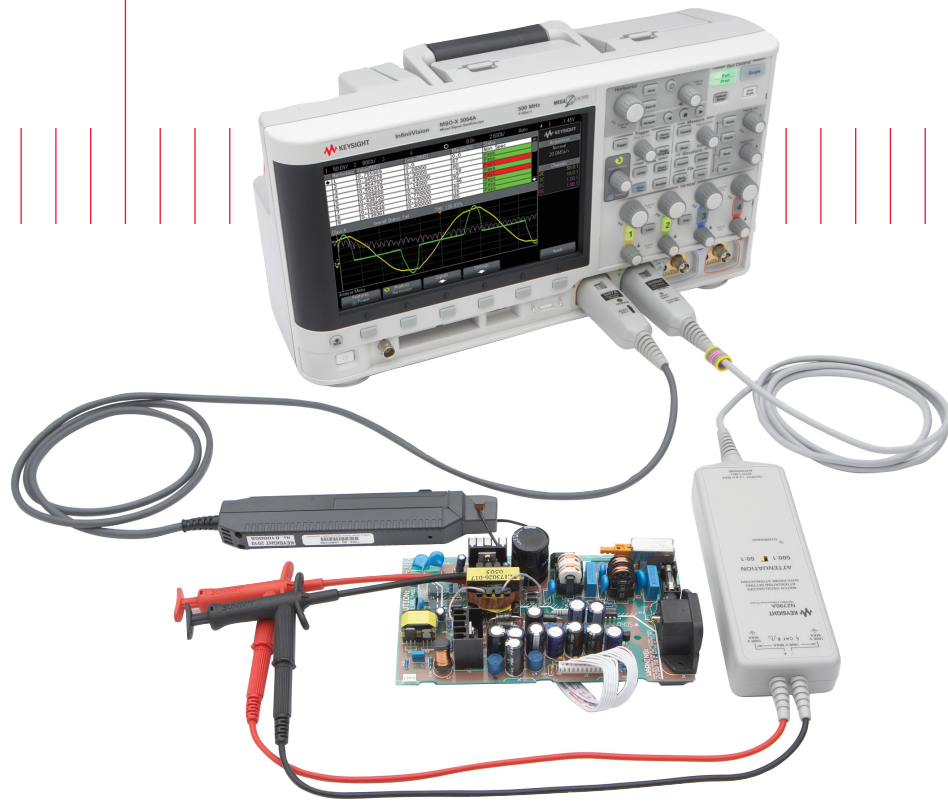

Achieve Cost-Effective Analysis of Your Switch Mode and Linear Power Supply Characteristics

Today's power supply designers are facing an increasing number of constraints in the development of high-efficiency, low-cost power supplies. Cost-effective solutions used to be the designer's key target. Today, rising energy costs bring power supply efficiency to the forefront. Additionally, other constraints such as design compactness, migration to digital control, tighter voltage tolerances, and regulations for power quality and EMI force the need for quick and thorough power supply testing. Increasing design constraints translate into more time dedicated to power device

measurement and analysis for today's power supply designers.

In spite of the increasing analysis capability offered by many oscilloscopes over recent years, it is not uncommon to see designers perform measurements and analysis manually. These measurements typically take a considerable amount of time to capture, analyze and report.

The Keysight Technologies, Inc. DSOX3PWR, DSOX4PWR, and DSOX6PWR are power measurement and analysis options that are

integrated into InfiniiVision 3000, 4000, and 6000 X-Series scopes. The embedded application provides a quick and easy way of analyzing the reliability, efficiency and performance of your switching and linear power supplies.

These power measurement options also come with the user license for the U1881A-003 PC-based power measurement and analysis software that provides even more powerful insight into your power supply measurements.

Type of analysis	Measurement	DSOX3PWR on 3000A	DSOX3PWR on 3000T	DSOX4PWR	DSOX6PWR
Input measurements	Power Quality:				
	Real power	•	•	•	•
	Apparent power	•	•	•	•
	Reactive power	•	•	•	•
	Power factor	•	•	•	•
	Crest factor (V&I)	•	•	•	•
	Phase Angle	•	•	•	•
	Current harmonics ¹	•	•	•	•
Inrush current	•	•	•	•	
Switching device measurements	Switching loss ²	•	•	•	•
	Rds(on)		•	•	•
	Vce(sat)		•	•	•
	Slew rate (V&I)	•	•	•	•
	Modulation analysis ³	•	•	•	•
Output measurements	Output ripple	•	•	•	•
	Turn-on time	•	•	•	•
	Turn-off time	•	•	•	•
	Efficiency ⁴	•	•	•	•
	Transient response settling time	•	•	•	•
Frequency response measurements	Power Supply Rejection Ratio (PSRR) ⁵	•	•	•	•
	Control Loop Response (Magnitude and phase plot) ⁵		•	•	•
Other	Auto probe deskew ⁶	•	•	•	•
	Auto Setup ⁷	•	•	•	•

Notes:

- Based on IEC 61000-3-2 standard for class A, B, C, and D products. Tabular or bar chart display user-selectable display formats with automatic pass/fail color-coded indication along with total harmonic distortion (THD).
- Power and energy losses based on $V \times I$ always, or $R_{ds(on)}$ or $V_{ce(sat)}$ during conduction phase only.
- Duty cycle, pulse width, frequency, period, etc., versus time trend plot.
- AC-to-DC, DC-to-AC, AC-to-AC, or DC-to-DC user-selectable efficiency measurements.
- Utilizes scope's built-in waveform generator. WaveGen option not required.
- Requires U1880A probe deskew fixture.
- Automatic setups with connections diagrams for all repetitive input measurements. Step-by-step instructions for all single-shot measurements including turn-on/off time, inrush current, and transient response.

Power Device Analysis

The switching loss in a power supply determines its efficiency. You can easily characterize for instantaneous power loss and conduction power loss at the switching device over a designated switching cycle. To determine the efficiency of the power supply it is very important to measure the power loss during dynamic load changes.

By measuring the switching loss and conduction loss, you can characterize the instantaneous power dissipation in your switching power supply. Locating peak switching loss helps you analyze the reliability of the power supply. The di/dt and dv/dt represent the rate at which the current and voltage change at switching. This helps in analysis of reliable operation of the switching mode power supply.

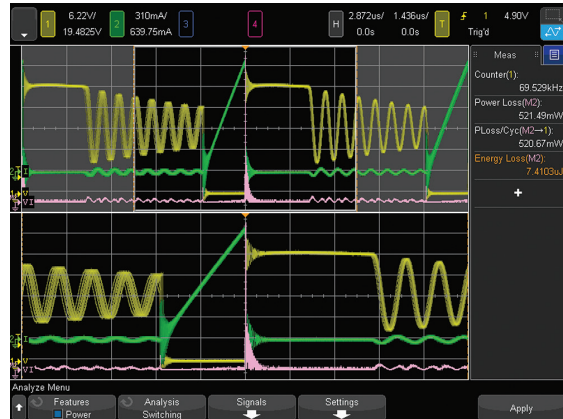

Figure 1. By measuring the switching loss and conduction loss, you can characterize the instantaneous power dissipation in a switching power supply.

Line Power Analysis

Power supply designers need to characterize the line power for power quality, harmonics and conducted emissions under different operating conditions of the power supply. Some of the implicit measurements are real power, apparent power, reactive power, power and crest factor and graphical display of harmonics with respect to standards such as IEC 61000-3-2 (Class A, B, C, D). By using a current probe and power measurement option, conducted power line harmonics can be measured. Also, line power analysis includes the inrush current measurement that shows the peak inrush current value when the power supply is first turned on.

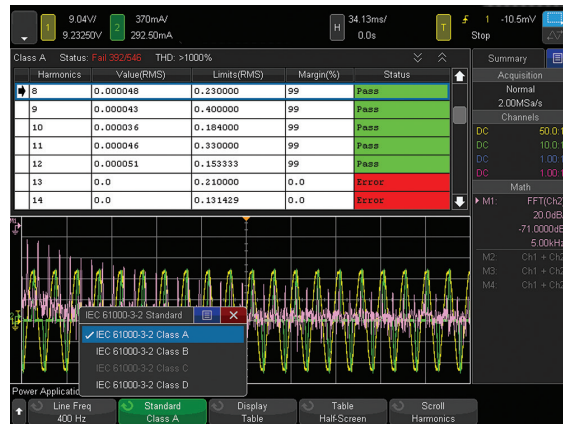

Figure 2. Perform the pre-compliance line harmonic testing of your power supply to the IEC 61000 3-2 standards. This analysis presents up to 40 harmonics.

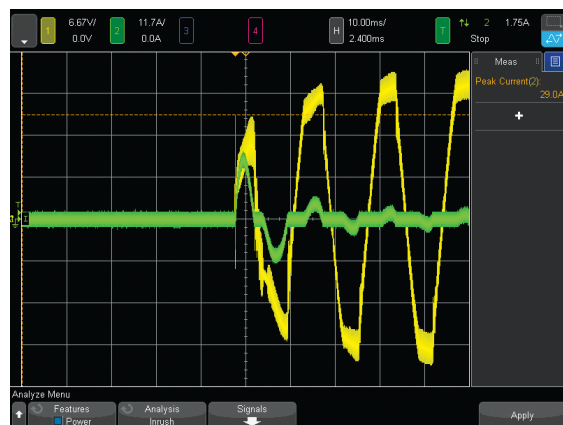

Figure 3. The Inrush current analysis measures the peak inrush current of the power supply when the power supply is first turned on.

Power Quality Analysis

The Power Quality analysis shows the quality of the AC input line. Some AC current may flow back into and back out of the load without delivering energy. This current, called reactive or harmonic current, gives rise to an “apparent” power which is larger than the actual power consumed. Power quality is gauged by these measurements: power factor, apparent power, true power, reactive power, crest factor, and phase angle of the current and voltage of the AC line.



Figure 4. The power measurements option provides a results table with the following power quality measurements: Power Factor, Real Power, Apparent Power, Reactive Power, Crest Factor and Phase Angle.

Modulation Analysis

Modulation analysis allows designers to quickly see the on-time and off-time information of the PWM signal, which is difficult to visualize because the information bandwidth is much lower than the pulse switching frequency. Plotting the embedded variation of on time or off time in the PWM signal over a long period of time can reveal the control loop response of the feedback loop system. This measurement performs data trending on the switching variation of the acquired waveform in the following format.

- Frequency vs time
- Period vs time
- Duty Cycle vs time
- Positive pulse width vs time
- Negative pulse width vs time



Figure 5. Plotting the embedded variation of on time or off time in the PWM signal over a long period of time can reveal the control loop response of the feedback loop system.

Output Analysis

Output analysis includes characterization of the ripple component (either power line or switching) in output DC voltage. Ripple is the residual AC component that is superimposed on the DC output of a power supply. Line frequency as well as switching frequency can contribute to ripple. This measurement analyzes the output voltage ripple and presents the peak-to-peak value as well as the frequency response of the captured signal.

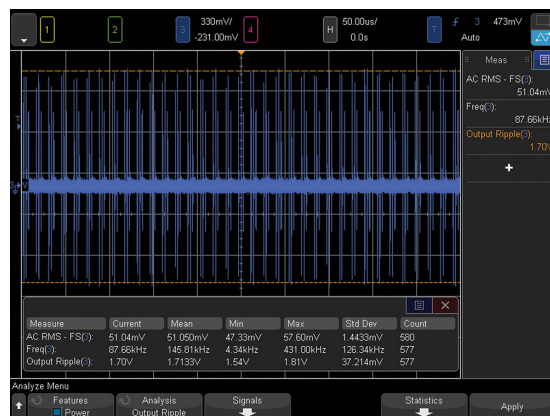

Figure 6. The output analysis includes characterizing the ripple component (either power line or switching) in output DC voltage.

Turn On/Off Time Analysis

This analysis measures the time taken to get to the steady output voltage of the power supply after the input voltage is applied (turn on time) and for the output voltage of the power supply to turn off after the input voltage is removed (turn off time).



Figure 7. The turn-on analysis measures the time taken to get to the steady output voltage of the power supply after the input voltage is applied.

Transient Response Analysis

Power supplies are subject to transient conditions, such as turn-on and turn-off transients, as well as sudden changes in output load and line input voltage. These conditions lead to one of the key specifications of the power supplies; load transient response. This analysis measures the load transient response of the DC output, namely the time taken for the DC output to stabilize during a load change.

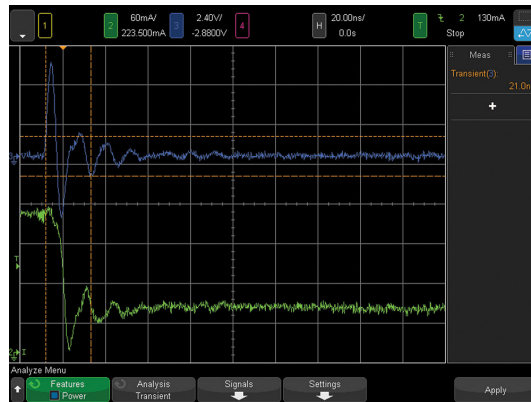

Figure 8. The transient analysis measures the load transient response of the DC output, namely the time taken for the DC output to stabilize during a load change.

Efficiency Analysis

Efficiency analysis tests the overall efficiency of the power supply by measuring the output power over the input power. This analysis requires a 4- channel oscilloscope because input voltage, input current, output voltage, and output current are measured.

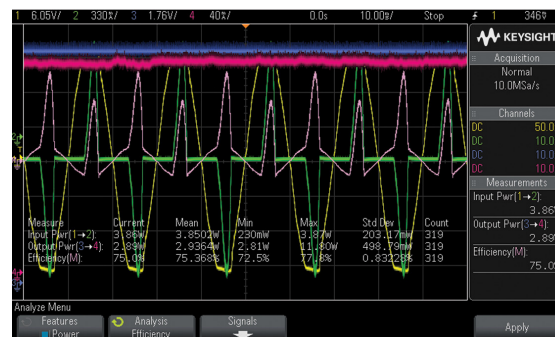

Figure 11. Efficiency analysis tests the overall efficiency of the power supply

PSRR (Power Supply Rejection Ratio)

Characterizing PSRR over frequency commonly involves the use of an expensive analyzer equipped with a DC bias port such as Keysight's ENA network analyzers.

The DSOX3PWR/DSOX4PWR/DSOX6PWR option utilizes the InfiniiVision built-in WaveGen BNC output that generates a swept frequency, simplifying the test solution in one box and significantly reducing the cost.

The PSRR is defined as the ratio of the input ripple compared to the output ripple over a wide frequency range and is expressed in dB. The basic equation for PSRR is

$$\text{PSRR} = 20 \log \frac{\text{Ripple input } (V_{in})}{\text{Ripple output } (V_{out})}$$

There may be many different methods to measure PSRR. One thing to note here is that because the oscilloscope has a higher noise floor and lower vertical sensitivity compared to a network analyzer, it is difficult to measure PSRR any better than -60 dB. A PSRR test using an oscilloscope with an integrated generator is usually considered to be acceptable for spot-checking overall PSRR behavior of the power supply under test. Using a modulated power supply to power the power supply under test is very useful for testing PSRR at heavy load conditions.

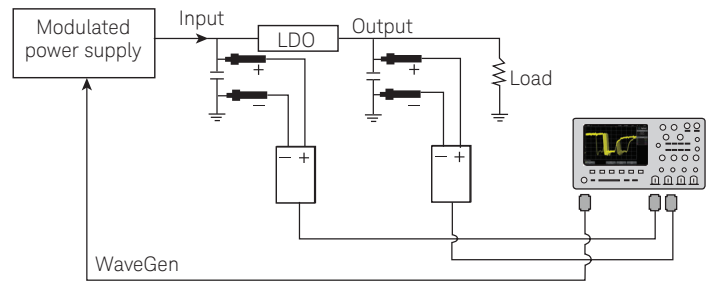

Figure 9. The PSRR is defined as the ratio of the output ripple compared to the input ripple over a wide frequency range.

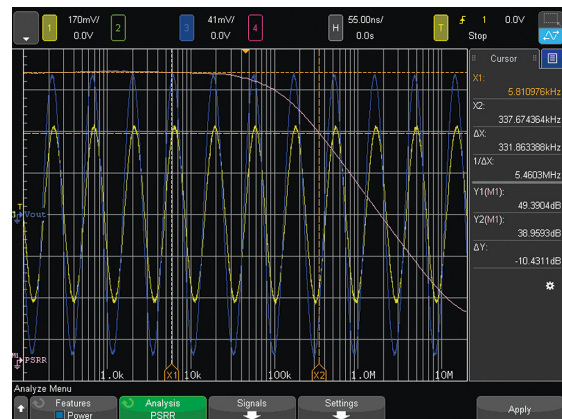

Figure 10. The PSRR is a measure of how well a circuit rejects ripple coming from the power supply input at various frequencies.

Control Loop Response (Bode)

A power supply is actually an amplifier with a negative feedback control loop as shown in Figure 2. This means that although you may think of a power supply as a DC amplifier, it actually amplifies AC to react to changes in output conditions, such as load changes.

Performing a Control Loop Response test requires that you inject an error signal over a band of frequencies into the feedback path of the control loop. The resistive-divider network of R1 and R2 is the feedback path in this diagram. To inject an error signal, a small resistor must be inserted into the feedback loop. The 5- Ω injection resistor shown in this schematic is insignificant in comparison to the series impedance of R1 and R2. So you might consider designing in this low-value injection resistor (R_{inj}) permanently for test purposes. An injection transformer, such as Picotest's J2101A, is also required so that the AC disturbance signal is isolated and doesn't induce any DC bias.

The measurement system, in this case an InfiniiVision X-Series oscilloscope with its built-in WaveGen function/AWG generator, measures AC voltage levels at the top of the feedback network (V_{in}) as well as at the regulated DC output (V_{out}) of the power supply. The scope then computes gain as $20\text{Log}(V_{out}/V_{in})$ at each frequency within the swept band. Also measured at the same time is the phase difference between V_{in} and V_{out} .

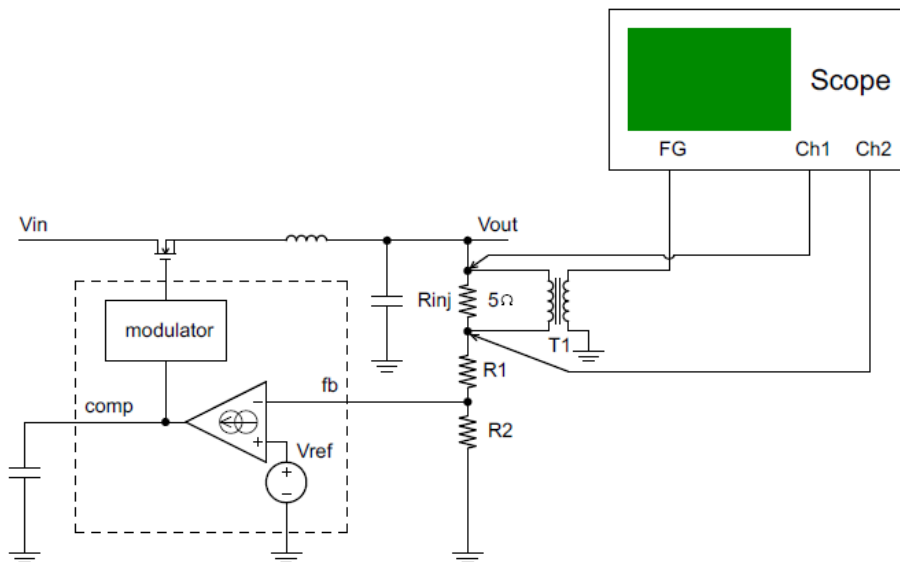

Figure 11. Power supply closed loop feedback network and oscilloscope connections for a Control Loop Response test.

Figure 4 shows the results of a Control Loop Response gain plot using an InfiniiVision X-Series oscilloscope. This test was performed using a swept frequency from 100 Hz up to 10 MHz. At the completion of the swept measurement, the 0 dB cross-over point was measured at approximately 6.6 kHz.

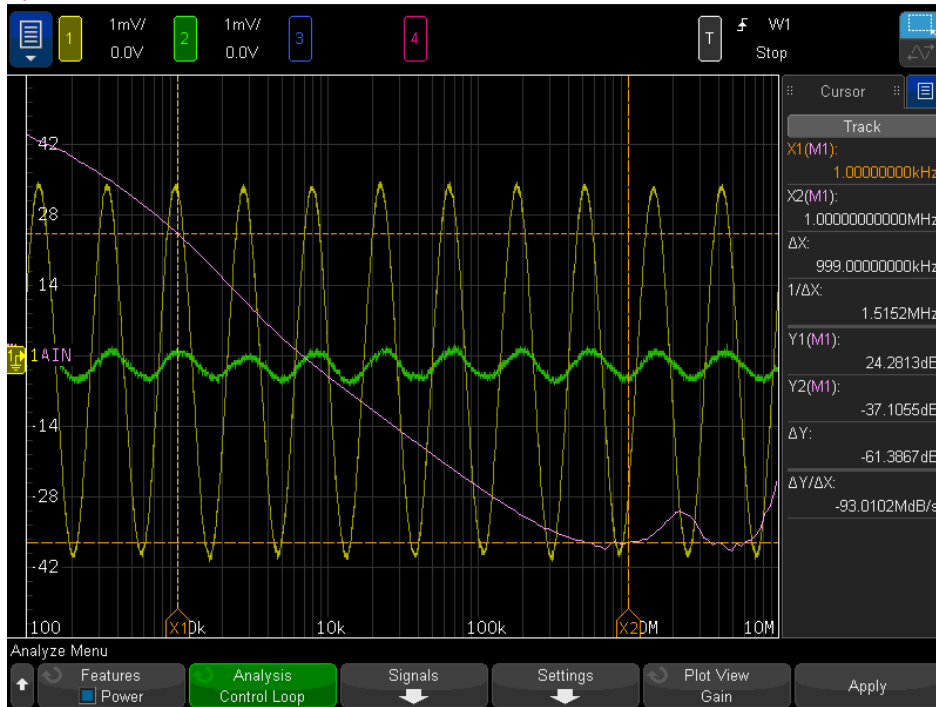

Figure 12. Control Loop Response gain measurement using an InfiniiVision X-Series oscilloscope.

A plot of the phase can also be viewed (not shown) after the completion of the gain test in order to measure phase margin. However, the amplitude of both V_{in} and V_{out} must exceed approximately 1 mVpp in order to measure phase at each test frequency.

Probe Deskewing With the U1880A Deskew Fixture

Timing delay errors between voltage and current probes may have a significant impact on power measurements as each specific voltage and current probes have different propagation delays. To make accurate power measurements and calculations, it is extremely important to null out the time delay between the voltage and current probes using a procedure known as “deskewing.” This step is critically important since a small offset in the timing of the voltage and current traces can cause a large error in the instantaneous power reading. By performing probe deskew before making power measurements, you can ensure the most accurate measurement.

The Keysight U1880A deskew fixture allows you to quickly deskew your voltage and current probes, enabling accurate and precise measurements of power supply efficiency. The U1880A deskew fixture generates a built-in voltage and current test signal and allows you to probe the same electrical point with a variety of voltage and current probes. With only a single click in one of the power measurements setup, deskewing is automatically performed and the deskew factors are saved in the power measurement application, so the next time when you launch the power measurement application, you can use the saved deskew values or perform the deskewing again.

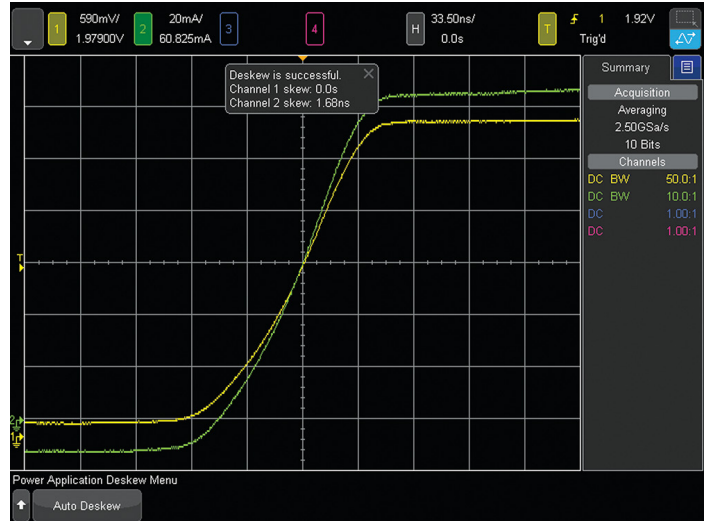

Figure 13. To make accurate power measurements and calculations, it is extremely important to null out the time delay between your voltage and current probes.

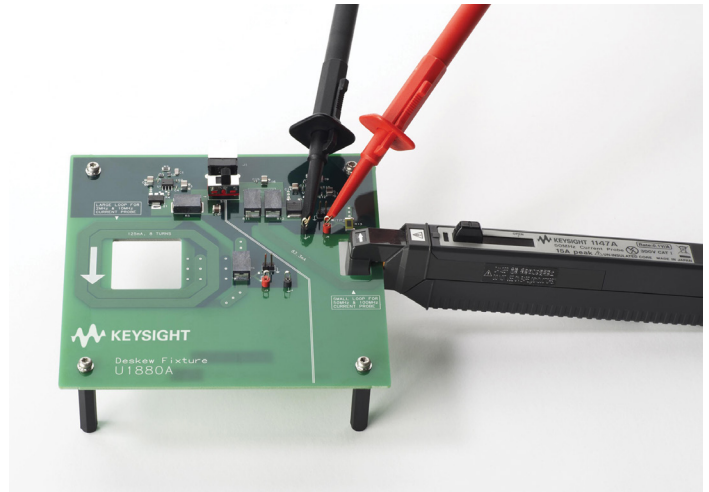

Figure 14. The Keysight U1880A deskew fixture allows you to quickly deskew your voltage and current probes, enabling accurate and precise measurements of power supply efficiency.

Ordering Information

Note* To learn more about the U1881A PC-based power measurement application for InfiniiVision oscilloscopes, refer to the U1881A data sheet with Keysight literature number 5989-7835EN.

Product number	Description
DSOX3PWR	Power Measurement software integrated into the 3000 X-Series (also includes the U1881A PC-based Power Measurement and Analysis* software license)
DSOX4PWR	Power Measurement software integrated into the 4000 X-Series (also includes the U1881A PC-based Power Measurement and Analysis software license)
DSOX6PWR	Power Measurement software integrated into the 6000 X-Series (also includes the U1881A PC-based Power Measurement and Analysis software license)
U1880A	Deskew fixture for voltage and current probe deskewing

Recommended Probes and Accessories

For more information about Keysight's scope probes and accessories, visit www.keysight.com/find/probes.

Recommended probes	
– AC/DC current probes (one or more of these Keysight current probes)	
– 1147B	50 MHz, 15 A AC/DC current probe with AutoProbe interface
– N2893B	100 MHz, 15 A AC/DC current probe with AutoProbe interface
– N2780B	2 MHz, 500 A AC/DC current probe (requires N2779A power supply)
– N2781B	2 MHz, 150 A AC/DC current probe (requires N2779A power supply)
– N2782B	2 MHz, 30 A AC/DC current probe (requires N2779A power supply)
– N2783B	2 MHz, 30 A AC/DC current probe (requires N2779A power supply)
Differential probes	
– N2790A	100 MHz, ± 1.4 kV differential probe
– N2791A	25 MHz, ± 700 V differential probe
– N2804A	300 MHz, ± 300 V differential probe
– N2805A	200 MHz, ± 100 V differential probe
– N2891A	70 MHz, ± 7 kV differential probe
Passive probe (for measuring output noise and PSRR)	
– N2870A	1:1 35 MHz passive probe
– N2804A	2.5 mm probe tip-to-PCB adapter

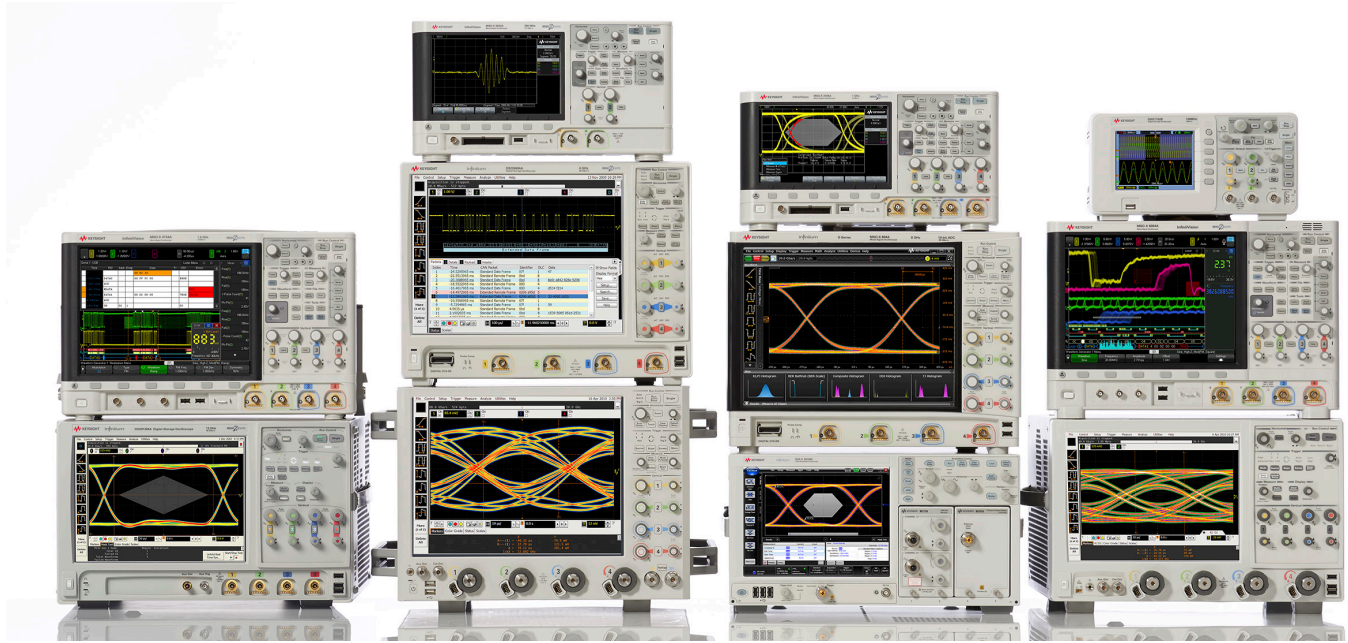

Keysight Oscilloscopes

Multiple form factors from 20 MHz to > 90 GHz | Industry leading specs | Powerful applications

myKeysight

myKeysight

www.keysight.com/find/mykeysight

A personalized view into the information most relevant to you.



www.axiestandard.org

AdvancedTCA® Extensions for Instrumentation and Test (AXIe) is an open standard that extends the AdvancedTCA for general purpose and semiconductor test. Keysight is a founding member of the AXIe consortium. ATCA®, AdvancedTCA®, and the ATCA logo are registered US trademarks of the PCI Industrial Computer Manufacturers Group.



www.lxistandard.org

LAN eXtensions for Instruments puts the power of Ethernet and the Web inside your test systems. Keysight is a founding member of the LXI consortium.



www.pxisa.org

PCI eXtensions for Instrumentation (PXI) modular instrumentation delivers a rugged, PC-based high-performance measurement and automation system.



Three-Year Warranty

www.keysight.com/find/ThreeYearWarranty

Keysight's commitment to superior product quality and lower total cost of ownership. The only test and measurement company with three-year warranty standard on all instruments, worldwide.



Keysight Assurance Plans

www.keysight.com/find/AssurancePlans

Up to five years of protection and no budgetary surprises to ensure your instruments are operating to specification so you can rely on accurate measurements.



www.keysight.com/go/quality

Keysight Technologies, Inc.
DEKRA Certified ISO 9001:2008
Quality Management System

Keysight Channel Partners

www.keysight.com/find/channelpartners

Get the best of both worlds: Keysight's measurement expertise and product breadth, combined with channel partner convenience.

For more information on Keysight Technologies' products, applications or services, please contact your local Keysight office. The complete list is available at: www.keysight.com/find/contactus

Americas

Canada	(877) 894 4414
Brazil	55 11 3351 7010
Mexico	001 800 254 2440
United States	(800) 829 4444

Asia Pacific

Australia	1 800 629 485
China	800 810 0189
Hong Kong	800 938 693
India	0124 229 2010
Japan	0120 (421) 345
Korea	080 769 0800
Malaysia	1 800 888 848
Singapore	1 800 375 8100
Taiwan	0800 047 866
Other AP Countries	(65) 6375 8100

Europe & Middle East

Austria	0800 001122
Belgium	0800 58580
Finland	0800 523252
France	0805 980333
Germany	0800 6270999
Ireland	1800 832700
Israel	1 809 343051
Italy	800 599100
Luxembourg	+32 800 58580
Netherlands	0800 0233200
Russia	8800 5009286
Spain	800 000154
Sweden	0200 882255
Switzerland	0800 805353
	Opt. 1 (DE)
	Opt. 2 (FR)
	Opt. 3 (IT)
United Kingdom	0800 0260637

For other unlisted countries:
www.keysight.com/find/contactus
(BP-02-06-15)