

Electrical Test:

1. 100%Test(Open ,short ,miss wire)
2. Contact Resistance: 2 ohm max.
3. Insulation Resistance: 10M ohm min.
4. Hi-pot:100V DC/10ms

注意事项:

- 1.两端均脱外被22MM,编织全部剪掉,芯线比剪15MM,地线保留22MM并点焊至铁壳;
- 2.焊点不易过大.

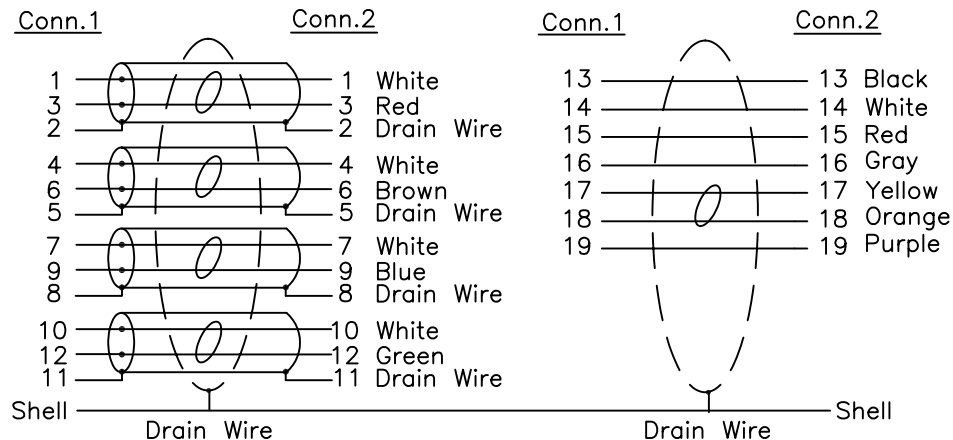

8	A7-R040041	THUMBSCREW: 5.5*24.5mm #4-40UNC Nickel Plated	2	pcs					
7	A6-0000015	HDMI Transparent Dust Cover	2	pcs	REV.	DESCRIPTION			DATE
6	A5-R047001	Outside Molding:45P PVC PMS:Black	16	g		TOLERANCE			TITLE: HDMI 28AWG 30# 2M Gold Plated
5	A5-R047011	Inside Molding:PE	3	g		.X	.015	.30	
4	A10-R075133	H.S.T ϕ 1.5*16mm Black	2	pcs		.XX	.010	.10	
3	A10-R075149	H.S.T ϕ 2.5*8mm Black	8	pcs	.XXX	.005	.05		
2	A2-R020044	HDMI 19P Male Shell Gold Plated,Insulation:Black	2	pcs	DRAWN BY	Cxmao			CUSTOMER : CPC
1	A4-R001221-A	UL20276 (28AWG*1PR+EAM)*4C+28AWG*1PR+28AWG*5C+AEB+Nylon SleeveMarking:1.3b OD:7.3MM Black L=2M	1	pcs	CHECK BY				CUSTOMER NO.: AV18747
NO.	ITEM	DESCRIPTION	Q'TY	UNIT	APPD BY	SCALE	NONE	DRAWING NO.: CAC250008	REV. A
						UNIT	MM		
						DATE	09.05.20		1/2

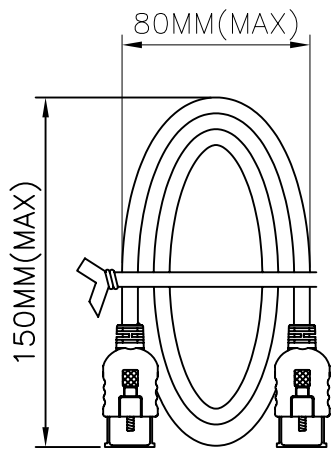

依图示尺寸绕线

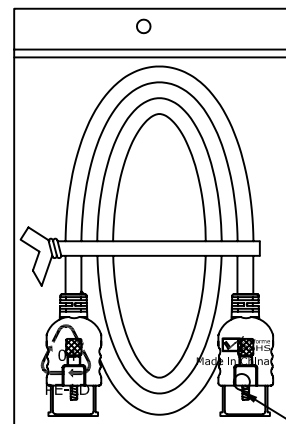
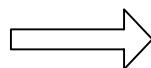

单PCS装夹链袋

透气孔

正唛:

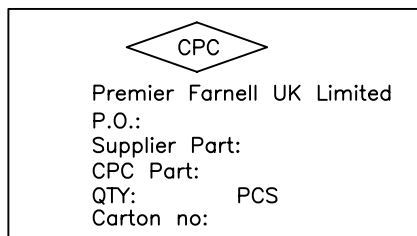

侧唛:

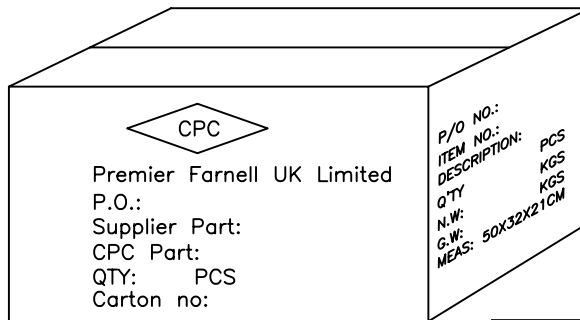
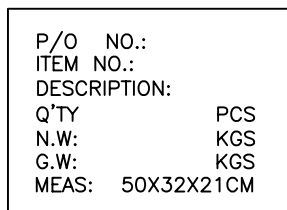

包装方式:

1. 如图所示每80PCS装箱, 上下各装一纸板。

5	A8-R053011	Waterproof:850*750*0.06MM	1/80	pcs
4	A9-H005006	Pasteboard:480*300MM B3C	2/80	pcs
3	A9-H008903	纸箱 K=K 500*320*210MM CPC客户 印:CPC...	1/80	pcs
2	A8-R053070	夹链袋 120*210*0.06MM 印带环保标志和RoHS...	1	pcs
1	A10-R043160	Cable Tie:L=240MM Black	1	pcs
NO.	ITEM	DESCRIPTION	Q'TY	UNIT

REV.	TOLERANCE		DESCRIPTION	DATE
	INCHES	M/M		
.X	.015	.30	TITLE: HDMI 28AWG 30# 2M Gold Plated	CUSTOMER : CPC CUSTOMER NO.: AV18747
.XX	.010	.10		
.XXX	.005	.05		
DRAWN BY	Cxmao		SCALE	NONE
CHECK BY			UNIT	MM
APPD BY			DATE	09.05.20
			DRAWING NO.:	REV. A
			CAC250008	2/2

规格 (Specification) :28AWG HDMI		OD:7.3mm			
部品 (Component)		COMPONENT A	COMPONENT B	COMPONENT C	
导体 (Conductor)	构造 (Constitution) AWG/mm	7/0.127 (28AWG)	7/0.127 (28AWG)	7/0.127 (28AWG)	
	材质 (Material)	TINNED COPPER STRANDED	TINNED COPPER STRANDED	TINNED COPPER STRANDED	
	绞合外径 (Cabling OD) mm	0.38	0.38	0.38	
绝缘 (Insulation)	芯线数量 (NO of wire)	4P	1P	5C	
	芯线材质 (Material)	FOAM-PE+SKIN	HDPE	HDPE	
	芯线直径 (OD) mm	1.0±0.05	0.70±0.05	0.70±0.05	
	平均厚度 (Thickness)mm	0.3	0.16	0.16	
	颜色 (Color)	1. WHITE&BROWN 2. WHITE&RED 3. WHITE&GREEN 4. WHITE&BLUE	5. YELLOW&ORANGE	6. WHITE 7. PURPLE 8. RED 9. BLACK 10. GRAY	
集合 (Cabling)	铝箔麦拉 (AL/MYLAR)	AL. FACE OUTSIDE.	/	/	
	地线 (Drain)	构造 (Constitution) N/mm	7/0.127 (28AWG)	/	
		材质 (Material)	TINNED COPPER STRANDED	/	
	麦拉 (MYLAR)	麦拉 (MYLAR)	MYLAR	/	/
		铝箔麦拉 (AL/MYLAR)	AL. FACE OUTSIDE.		
		地线 (Drain)	7/0.127T (28AWG)		
编织 (Braid)	构造 (Constitution) N/mm	16/5/0.12			
	材质 (Material)	ALUMINIUM MAGNESIUM ALLOY			
	屏蔽率 (Coverage) %	50% ↑			
外被 (Jacket)	外被材质 (Material)	PVC			
	外被线径 (OD) mm	7.3±0.20			
	平均厚度 (Thickness)mm	0.80 (REF)			
	印字轮 (Marking)	E301195  AWM STYLE 20276 80°C 30V VW-1 HDMI REV1.3b CABLE			
	硬度 (Hardness)A	SHORE. A 80±3			
	颜色 (Color)	BLACK (PAK HENG COLOR CODE L0106D)			
UL型号 (Style)	UL20276				

电气性能 (Electric Characters):	物理性能 (Physical Characters):
1. Voltage rating: 30V 2. Temperature rating: 80°C 3. Spark test: AC- 1500V/In the air 4. Dielectric strength: AC-500V/ MIN 5. Insulation resistance: FOAM-PE/PE DC-500V 100MΩ. KM MIN. at 20°C 6. Conductor resistance: 28AWG-237Ω/KM MAX at 20°C 7. Impedance: 100±10Ω 8. Attenuation: at 0.3~825MHz<5dB/cable; at 0.825~2.475GHz<12dB/cable at 2.475~4.125GHz<20dB/cable at 4.125~5.100GHz<25dB/cable 9. Time Delay Skew: within a pair: ≤112ps/cable between pairs: ≤1.78ns/cable	1. Tensile strength test are before aging: JACKET:1500PSI min Aged:70% min 2. Elongation before aging: JACKET:100% min Aged:65% min 3. flame test of cable: VW-1

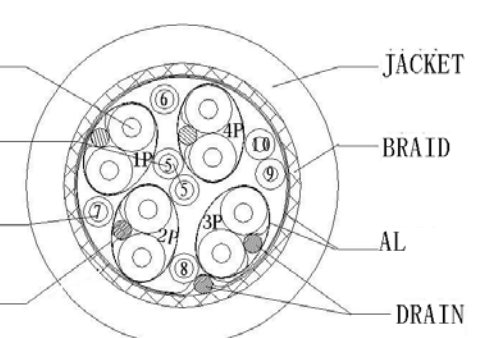
附产品图 (Diagram):	客户签回 (CUSTOMER'S SIGN):	
		完全接受 (FULL APPROVED) 拒收 (REJECTED)
	客户签名 (CUSTOMER'S SIGN)	
	备注 (NOTE)	
	APPROVE: PENG	PART NO:
	AUDITING:	EDITION:H0150803
	DRAWING: Yang	DATE:2008. 10. 07
	文件编号: PHQ4-EN-01-05	