

500 mA very low drop voltage regulator

Datasheet - production data



Features

- Input voltage from 2.5 to 16 V
- Very low dropout voltage (300 mV max. at 500 mA load)
- Low quiescent current (200 μ A typ. @ 500 mA load)
- Available in 1% precision in PPAK and DFN6 packages, 2% in DPAK
- 500 mA guaranteed output current
- Wide range of output voltages available on request: adjustable from 0.8 V, fixed up to 12 V in 100 mV steps
- Logic-controlled electronic shutdown
- Power Good (PPAK and DFN packages)
- Fast dynamic response to line and load changes
- Internal current and thermal protection
- Temperature range: - 40 °C to 125 °C

Applications

- PCs and laptop computers
- Battery-powered equipment
- Industrial and medical equipment
- Portable equipment

Description

The LDFM is a fast, very low drop linear regulator which operates from an input supply voltage in the range of 2.5 V to 16 V.

It is available in fixed and adjustable output voltage versions, from 0.8 V to 12 V.

The LDFM features high output precision, very low dropout voltage, low noise, and low quiescent current, therefore suitable for low voltage microprocessors and memory applications.

Enable logic control pin and Power Good output are featured on PPAK/DFN packages.

Current and thermal protection are provided.

Contents

| | | |
|-----------|--|-----------|
| 1 | Block diagram | 3 |
| 2 | Pin configuration | 4 |
| 3 | Typical application | 5 |
| 4 | Absolute maximum ratings | 6 |
| 5 | Electrical characteristics | 7 |
| 6 | Application information | 11 |
| 6.1 | External capacitors | 11 |
| 6.1.1 | Input capacitor | 11 |
| 6.1.2 | Output capacitor | 11 |
| 6.2 | Enable pin operation | 11 |
| 6.3 | Power Good | 11 |
| 7 | Typical performance characteristics | 12 |
| 8 | Package information | 16 |
| 8.1 | PPAK package information | 17 |
| 8.2 | DPAK package information | 19 |
| 8.3 | PPAK and DPAK packing information | 22 |
| 8.4 | DFN6 (2 x 2 mm) package information | 24 |
| 8.5 | DFN6 (2 x 2 mm) packing information | 27 |
| 8.6 | DFN6 (3 x 3 mm) package information | 29 |
| 8.7 | DFN6 (3 x 3 mm) packing information | 32 |
| 9 | Order code | 34 |
| 10 | Revision history | 35 |

1 Block diagram

Figure 1. Block diagram (generic version)

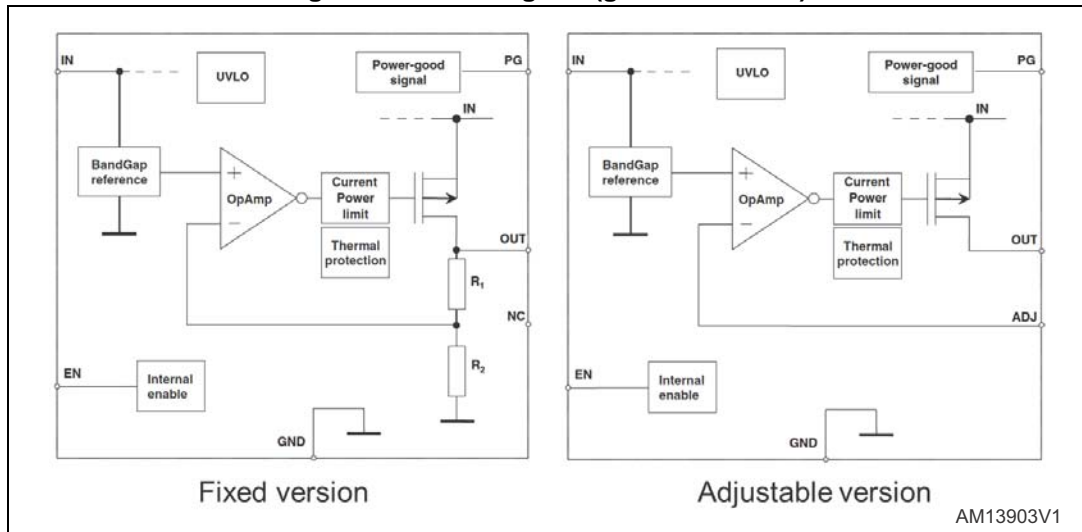

2 Pin configuration

Figure 2. Pin connection (top view)

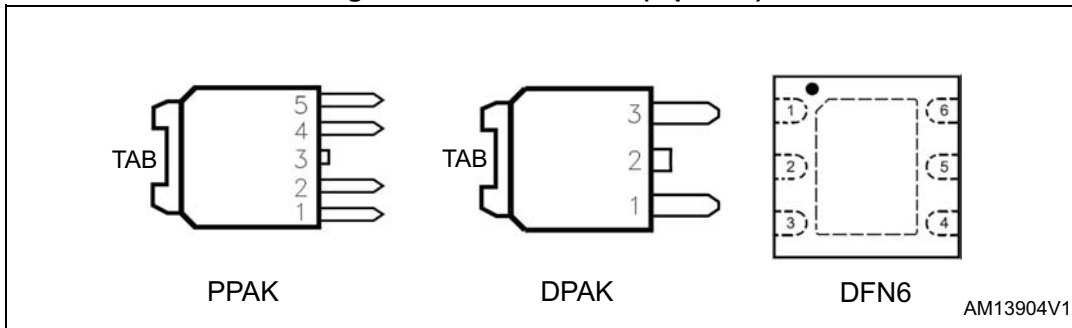

Table 1. Pin description DPAK, PPAK

| Pin n° | | Symbol | Function |
|--------|------|------------------|---|
| PPAK | DPAK | | |
| 5 | - | ADJ/PG | For adjustable versions: Error amplifier input pin. For fixed version: Power Good output |
| 2 | 1 | V _{IN} | Input voltage |
| 4 | 3 | V _{OUT} | Output voltage |
| 1 | - | EN | Enable pin logic input: Low = shutdown, High = active |
| 3 | 2 | GND | Ground |
| TAB | TAB | GND | Ground |

Table 2. Pin description DFN6-2x2 and 3x3

| Pin n° | Symbol | Function |
|-------------|------------------|---|
| 2 | ADJ/NC | For adjustable versions: error amplifier input pin. For fixed version: not connected |
| 6 | V _{IN} | Input voltage |
| 1 | V _{OUT} | Output Voltage |
| 5 | EN | Enable pin logic input: low = shutdown, high = active |
| 3 | PG | Power good output |
| 4 | GND | Ground |
| exposed pad | GND | Ground |

3 Typical application

Figure 3. Fixed versions

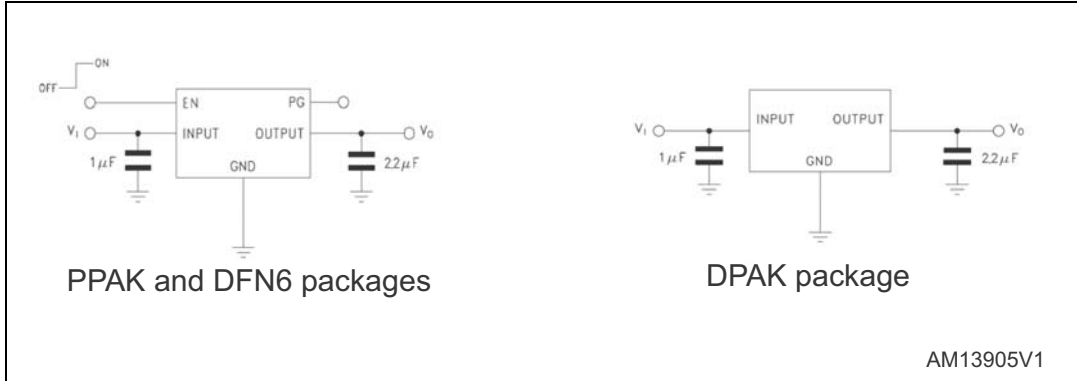
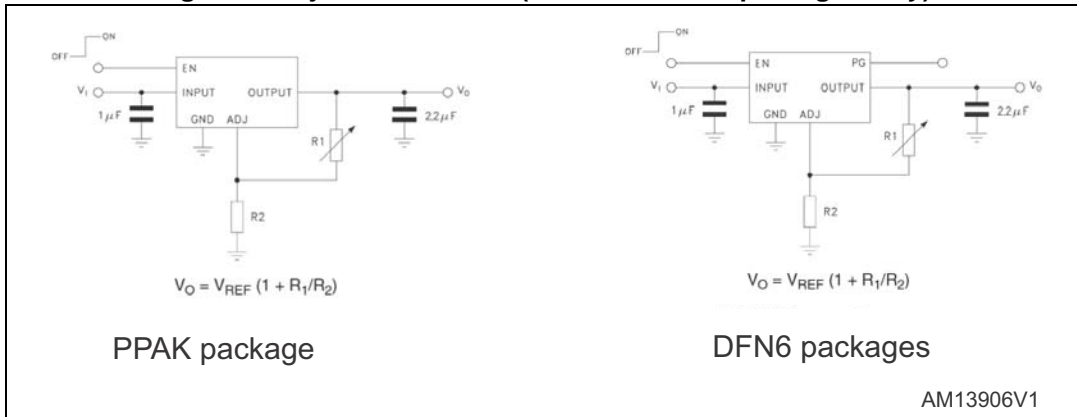

Figure 4. Adjustable version (PPAK and DFN6 packages only)



4 Absolute maximum ratings

Table 3. Absolute maximum ratings

| Symbol | Parameter | Value | Unit |
|------------|--------------------------------------|-------------------------|------|
| V_{IN} | DC input voltage | - 0.3 to 20 | V |
| V_{OUT} | DC output voltage | - 0.3 to $V_{IN} + 0.3$ | V |
| V_{EN} | Enable input voltage | - 0.3 to $V_{IN} + 0.3$ | V |
| V_{ADJ} | Adjust pin voltage | - 0.3 to 2 | V |
| V_{PG} | Power Good pin voltage | - 0.3 to $V_{IN} + 0.3$ | V |
| I_{LOAD} | Output current | Internally limited | mA |
| P_D | Power dissipation | Internally limited | mW |
| T_{STG} | Storage temperature range | - 65 to 150 | °C |
| T_{OP} | Operating junction temperature range | - 40 to 125 | °C |

Note: Absolute maximum ratings are those values beyond which damage to the device may occur. Functional operation under these conditions is not implied. All values are referred to GND.

Table 4. Thermal data

| Symbol | Parameter | Value | | | | Unit |
|------------|-------------------------------------|-------|------|----------|----------|------|
| | | PPAK | DPAK | DFN6-2x2 | DFN6-3x3 | |
| R_{thJA} | Thermal resistance junction-ambient | 100 | 100 | 65 | 55 | °C/W |
| R_{thJC} | Thermal resistance junction-case | 8 | 8 | 6.5 | 10 | °C/W |

5 Electrical characteristics

$T_J = 25\text{ °C}$, $V_{IN} = V_{OUT(NOM)} + 1\text{ V}^{(1)}$, $C_{IN} = 1\text{ }\mu\text{F}$, $C_{OUT} = 2.2\text{ }\mu\text{F}$, $I_{LOAD} = 10\text{ mA}$, $V_{EN} = 2\text{ V}$, unless otherwise specified.

Table 5. Electrical characteristics for LDFM (fixed versions)

| Symbol | Parameter | Test conditions | Min. | Typ. | Max. | Unit |
|------------------|--|---|------|------|------|---------------|
| V_{IN} | Operating input voltage | | 2.5 | | 16 | V |
| V_{OUT} | V_{OUT} accuracy, PPAK and DFN6 versions | $V_{OUT} + 1\text{ V}^{(1)} \leq V_{IN} \leq 16\text{ V}$ $I_{LOAD} = 10\text{ mA}$ | -1 | | 1 | % |
| | | $10\text{ mA} \leq I_{LOAD} \leq 500\text{ mA}$ $T_J = -40\text{ to }125\text{ °C}$ | -1.5 | | 1.5 | % |
| V_{OUT} | V_{OUT} accuracy, DPAK version | $V_{OUT} + 1\text{ V}^{(1)} \leq V_{IN} \leq 16\text{ V}$ $I_{LOAD} = 10\text{ mA}$ | -2 | | 2 | % |
| | | $10\text{ mA} \leq I_{LOAD} \leq 500\text{ mA}$ $T_J = -40\text{ to }125\text{ °C}$ | -3 | | 3 | % |
| ΔV_{OUT} | Static line regulation | $V_{OUT} + 1\text{ V}^{(1)} \leq V_{IN} \leq 16\text{ V}$ | | 0.01 | | %V |
| | | $V_{OUT} + 1\text{ V}^{(1)} \leq V_{IN} \leq 16\text{ V}$, $T_J = -40\text{ to }125\text{ °C}$ | | | 0.04 | |
| ΔV_{OUT} | Static load regulation | $10\text{ mA} \leq I_{LOAD} \leq 500\text{ mA}$ | | 0.1 | | %A |
| | | $10\text{ mA} \leq I_{LOAD} \leq 500\text{ mA}$, $T_J = -40\text{ to }125\text{ °C}$ | | 0.15 | 0.4 | |
| | | $10\text{ mA} \leq I_{LOAD} \leq 500\text{ mA}$, $T_J = -40\text{ to }125\text{ °C}$ DFN6 version | | | 10 | mV |
| V_{DROP} | Dropout voltage ⁽²⁾ | $I_{LOAD} = 500\text{ mA}$, $-40\text{ °C} < T_J < 125\text{ °C}$ | | 125 | 300 | mV |
| I_Q | Quiescent current | ON mode: $V_{EN} = 2\text{ V}$ $I_{LOAD} = 10\text{ mA to }500\text{ mA}$, $T_J = -40\text{ to }125\text{ °C}$ | | 200 | 800 | μA |
| | | OFF Mode: $V_{EN} = \text{GND}$, PPAK and DFN versions | | 30 | | |
| | | OFF Mode: $V_{EN} = \text{GND}$, PPAK and DFN versions, $-40\text{ °C} < T_J < 125\text{ °C}$ | | | 120 | |
| I_{SC} | Short-circuit current | | | 0.8 | | A |
| V_{EN} | Enable input logic low | $V_{IN} = 2.5\text{ V to }16\text{ V}$, $-40\text{ °C} < T_J < 125\text{ °C}$ | | | 0.8 | V |
| | Enable input logic high | | 2 | | | |
| I_{EN} | Enable pin input current | $V_{EN} = V_{IN}$ | | 5 | 10 | μA |

Table 5. Electrical characteristics for LDFM (fixed versions) (continued)

| Symbol | Parameter | Test conditions | Min. | Typ. | Max. | Unit |
|-------------------|-------------------------------|---|------|---------------------------|------|--|
| PG | Power Good output threshold | Rising edge | | 0.92* V _{OUT} | | V |
| | | Falling edge | | 0.8* V _{OUT} | | |
| | Power Good output voltage low | I _{SINK} = 6 mA, open drain output | | 0.4 | | |
| SVR | Supply voltage rejection | V _{IN} = 6 V +/- 0.5 V _{RIPPLE} Freq. = 120 Hz, V _{OUT} = 5 V | | 60 | | dB |
| | | V _{IN} = 6 V +/- 0.5 V _{RIPPLE} Freq. = 10 kHz, V _{OUT} = 5 V | | 52 | | |
| e _N | Output noise voltage | Bw = 10 Hz to 100 kHz, I _{LOAD} = 100 mA. C _{OUT} = 2.2 μF | | 45 | | μV _{RMS} /V _{OUT} |
| T _{SHDN} | Thermal shutdown | | | 170 | | °C |
| | Hysteresis | | | 10 | | |

1. For V_{OUT} < 1.5 V; V_{IN} = 2.5 V
2. Dropout voltage is the input-to-output voltage difference at which the output voltage is 100 mV below its nominal value. This specification does not apply for output voltages below 1.5 V.

$T_J = 25\text{ °C}$, $V_{IN} = V_{OUT(NOM)} + 1\text{ V}^{(1)}$, $C_{IN} = 1\text{ }\mu\text{F}$, $C_{OUT} = 2.2\text{ }\mu\text{F}$, $I_{LOAD} = 10\text{ mA}$, $V_{EN} = 2\text{ V}$, unless otherwise specified.

Table 6. Electrical characteristics for LDFM (adjustable version)

| Symbol | Parameter | Test conditions | Min. | Typ. | Max. | Unit |
|------------------|--------------------------------|---|------|-------|------|---------------|
| V_{IN} | Operating input voltage | | 2.5 | | 16 | V |
| V_{ADJ} | Reference voltage | $V_{IN} = V_{OUT} + 1\text{ V}^{(1)}$ | | 0.8 | | V |
| | Reference voltage tolerance | $V_{OUT} + 1\text{ V}^{(1)} \leq V_{IN} \leq 16\text{ V}$ $I_{LOAD} = 10\text{ mA}$ | -1 | | 1 | % |
| | | $10\text{ mA} \leq I_{LOAD} \leq 500\text{ mA}$ $T_J = -40\text{ to }125\text{ °C}$ | -1.5 | | 1.5 | |
| ΔV_{OUT} | Static line regulation | $V_{OUT} + 1\text{ V}^{(1)} \leq V_{IN} \leq 16\text{ V}$ | | 0.01 | | %V |
| | | $V_{OUT} + 1\text{ V}^{(1)} \leq V_{IN} \leq 16\text{ V}$, $T_J = -40\text{ to }125\text{ °C}$ | | | 0.04 | |
| ΔV_{OUT} | Static load regulation | $10\text{ mA} \leq I_{LOAD} \leq 500\text{ mA}$ | | 0.06 | | %A |
| | | $10\text{ mA} \leq I_{LOAD} \leq 500\text{ mA}$, $T_J = -40\text{ to }125\text{ °C}$ | | 0.2 | 0.4 | |
| | | $10\text{ mA} \leq I_{LOAD} \leq 500\text{ mA}$, $T_J = -40\text{ to }125\text{ °C}$ DFN6 version | | | | 10 |
| V_{DROP} | Dropout voltage ⁽²⁾ | V_{OUT} fixed to 2.5 V, $I_{LOAD} = 500\text{ mA}$, $-40\text{ °C} < T_J < 125\text{ °C}$ | | 125 | 300 | mV |
| I_Q | Quiescent current | ON mode: $V_{EN} = 2\text{ V}$ $I_{LOAD} = 10\text{ mA to }500\text{ mA}$, $T_J = -40\text{ to }125\text{ °C}$ | | 200 | 800 | μA |
| | | OFF Mode: $V_{EN} = \text{GND}$, PPAK and DFN versions | | 30 | | |
| | | OFF Mode: $V_{EN} = \text{GND}$, PPAK and DFN versions, $-40\text{ °C} < T_J < 125\text{ °C}$ | | | 120 | |
| I_{SC} | Short-circuit current | | | 0.8 | | A |
| V_{EN} | Enable input logic low | $V_{IN} = 2.5\text{ V to }16\text{ V}$, $-40\text{ °C} < T_J < 125\text{ °C}$ | | | 0.8 | V |
| | Enable input logic high | | 2 | | | |
| I_{EN} | Enable pin input current | $V_{EN} = V_{IN}$ | | 5 | 10 | μA |
| PG | Power Good output threshold | Rising edge | | 0.92* | | V |
| | | Falling edge | | 0.8* | | |
| | Power Good output voltage low | $I_{SINK} = 6\text{ mA}$, open drain output | | | 0.4 | |

Table 6. Electrical characteristics for LDFM (adjustable version) (continued)

| Symbol | Parameter | Test conditions | Min. | Typ. | Max. | Unit |
|-------------------|--------------------------|--|------|------|------|--|
| SVR | Supply voltage rejection | $V_{IN} = V_{OUT} + 1 \text{ V} \pm 0.5 V_{RIPPLE}$ Freq. = 120 Hz, $V_{OUT} = 0.8 \text{ V}$ | | 62 | | dB |
| | | $V_{IN} = V_{OUT} + 1 \text{ V} \pm 0.5 V_{RIPPLE}$ Freq. = 10 kHz, $V_{OUT} = 0.8 \text{ V}$ | | 55 | | |
| e_N | Output noise voltage | Bw = 10 Hz to 100 kHz, $I_{LOAD} = 100 \text{ mA}$. $C_{OUT} = 2.2 \mu\text{F}$ | | 50 | | $\frac{\mu\text{V}_{\text{RMS}}}{\text{s}/V_{\text{OUT}}}$ |
| T_{SHDN} | Thermal shutdown | | | 170 | | °C |
| | Hysteresis | | | 10 | | |

1. For $V_{OUT} < 1.5 \text{ V}$; $V_{IN} = 2.5 \text{ V}$.
2. Dropout voltage is the input-to-output voltage difference at which the output voltage is 100 mV below its nominal value. This specification does not apply for output voltages below 1.5 V.

6 Application information

6.1 External capacitors

The LDFM requires external capacitors for regulator stability. These capacitors must be selected to meet the requirements of minimum capacitance and equivalent series resistance (see [Figure 25 and 26](#)). It is advisable to locate the input/output capacitors as close as possible to the relative pins.

6.1.1 Input capacitor

An input capacitor with a minimum value of 1 μF is required with the LDFM. This capacitor must be located a distance of not more than 0.5" from the input pin of the device and returned to a clean analog ground. Any good quality ceramic capacitors can be used for this capacitor.

6.1.2 Output capacitor

It is possible to use ceramic capacitors but the output capacitor must meet the requirements for minimum amount of capacitance and E.S.R. (equivalent series resistance) value.

A minimum capacitance of 2.2 μF is a good choice to guarantee the stability of the regulator. However, other C_{OUT} values can be used according to [Figure 25 and 26](#), showing the allowable ESR range as a function of the output capacitance.

The output capacitor must maintain its ESR in the stable region over the full operating temperature range to assure stability. Also, capacitor tolerance and variation with temperature must be kept in consideration in order to assure the minimum amount of capacitance at all times.

6.2 Enable pin operation

The Enable pin can be used to turn OFF the regulator when pulled down, so drastically reducing the current consumption. When the enable feature is not used, this pin must be tied to V_{IN} to keep the regulator output ON at all times. To assure proper operation, the signal source used to drive the Enable pin must be able to swing above and below the specified thresholds listed in the electrical characteristics section (V_{EN}). The Enable pin must not be left floating because it is not internally pulled down/up.

6.3 Power Good

The LDFM features an open drain Power Good (PG) pin to sequence external supplies or loads and to provide fault detection. This pin requires an external resistor (R_{PG}) to pull PG high when the output is within the PG tolerance window. Typical values for this resistor range from 10 k Ω to 100 k Ω .

7 Typical performance characteristics

$C_{IN} = C_{OUT} = 1 \mu F$, $V_{IN} = V_{OUT} + 1 V$, V_{EN} to V_{IN} , $I_{OUT} = 10 mA$, unless otherwise specified.

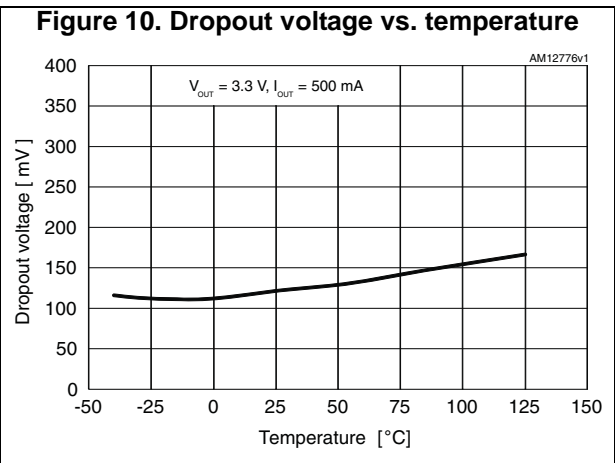
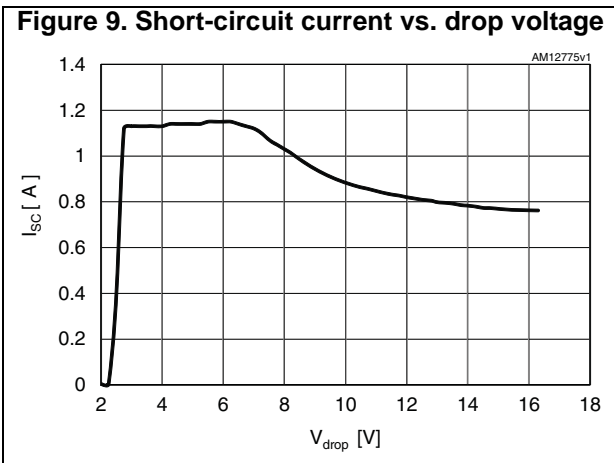
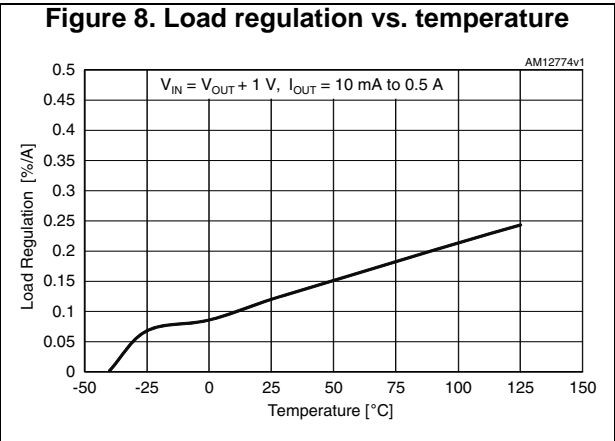
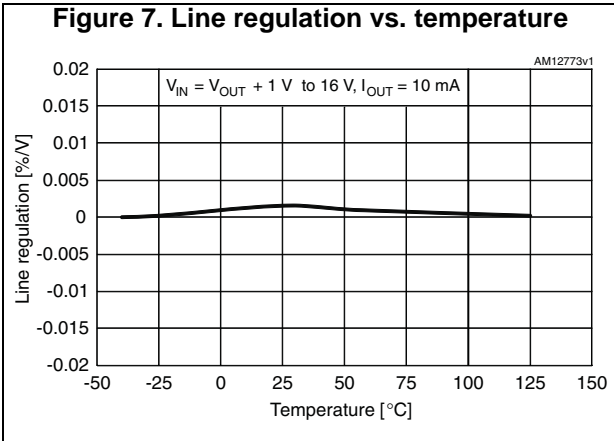
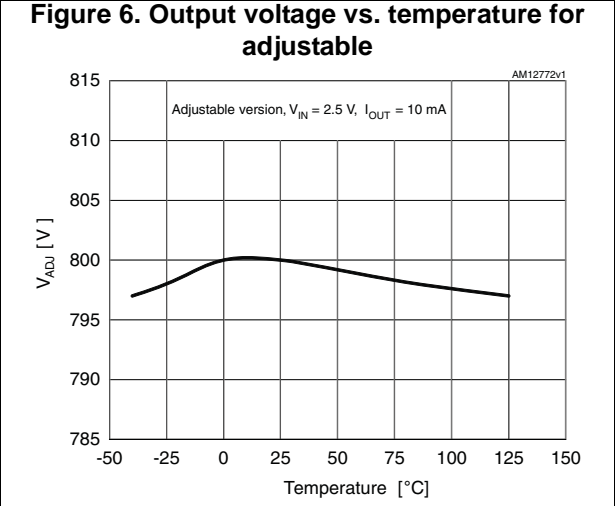
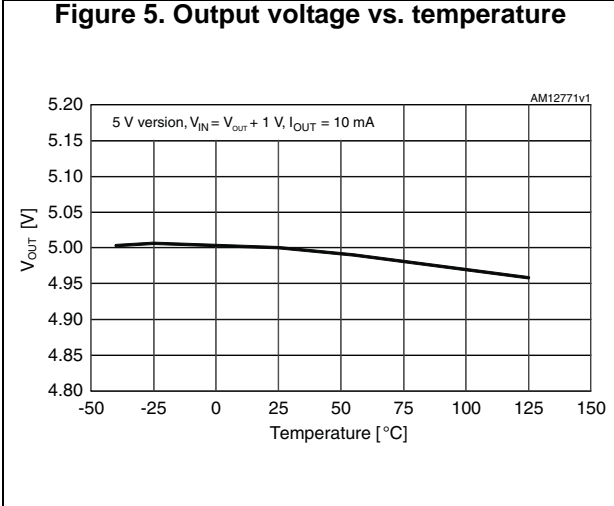

Figure 11. Quiescent current vs. temperature
($I_{OUT} = 10 \text{ mA}$)

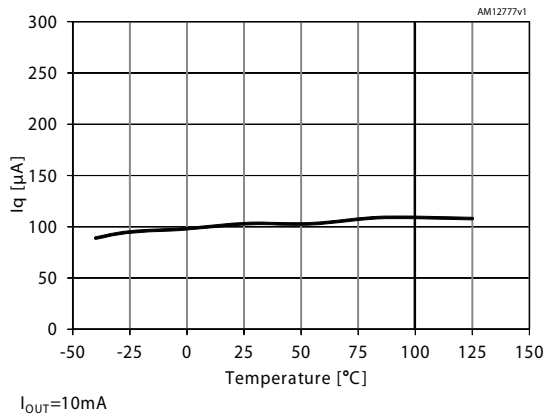

Figure 12. Quiescent current vs. temperature
($I_{OUT} = 500 \text{ mA}$)

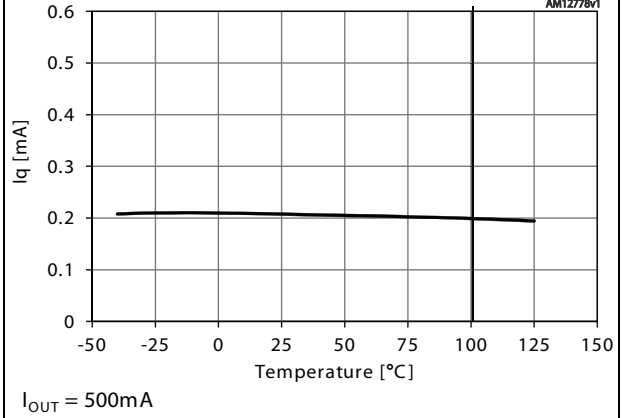

Figure 13. Shutdown current vs. temperature

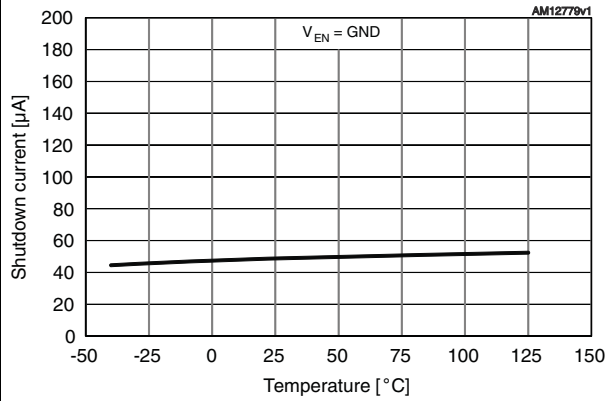

Figure 14. Enable pin current vs. temperature

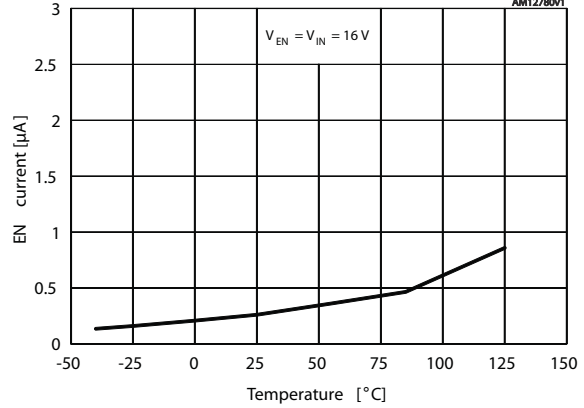

Figure 15. Enable high threshold vs. temperature

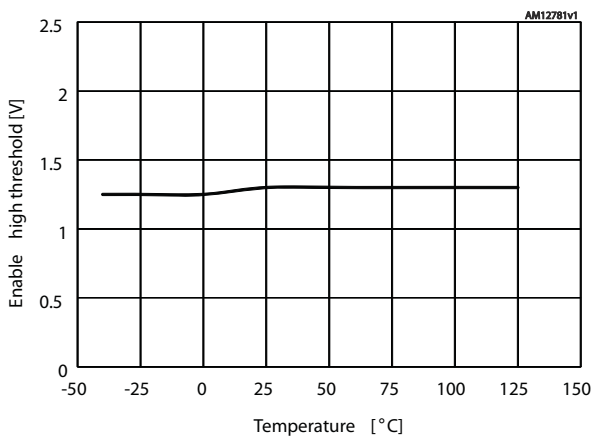

Figure 16. Enable low threshold vs. temperature

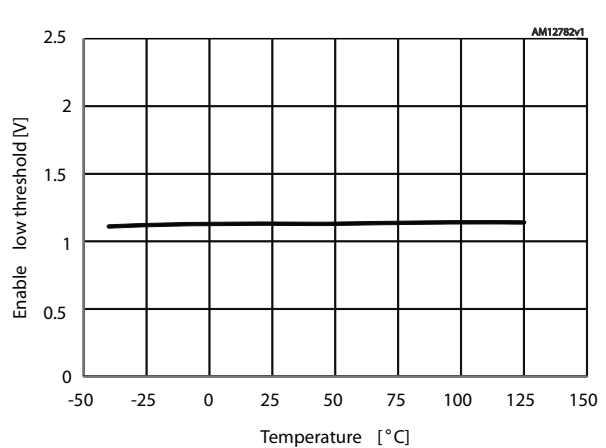

Figure 17. Output voltage vs. input voltage

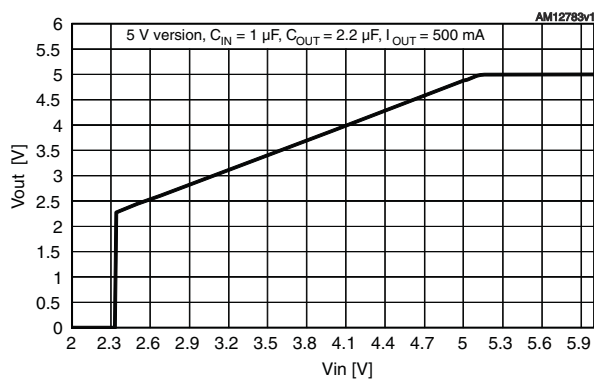
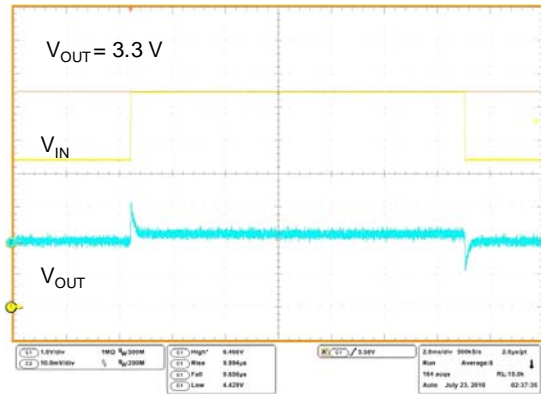
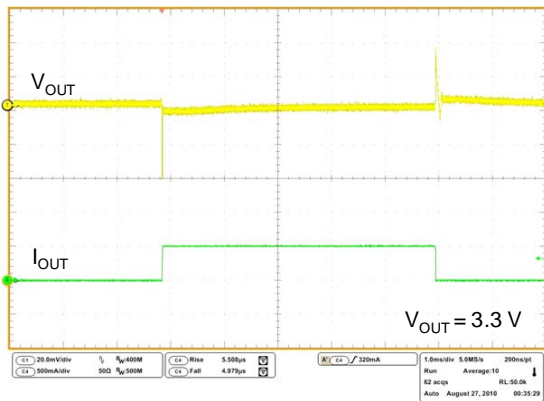

Figure 18. Line transient



V_{IN} = from 4.5 to 6.5 V, I_{OUT} = 10 mA, $t_{rise} = t_{fall} = 10 \mu s$, $C_{OUT} = 2.2 \mu F$

Figure 19. Load transient ($V_{OUT} = 3.3 V$)



$V_{EN} = V_{IN} = 4.5 V$, I_{OUT} = from 1 to 500 mA, $t_{rise} = t_{fall} = 5 \mu s$, $C_{OUT} = 2.2 \mu F$

Figure 20. Load transient ($V_{OUT} = V_{ADJ}$)

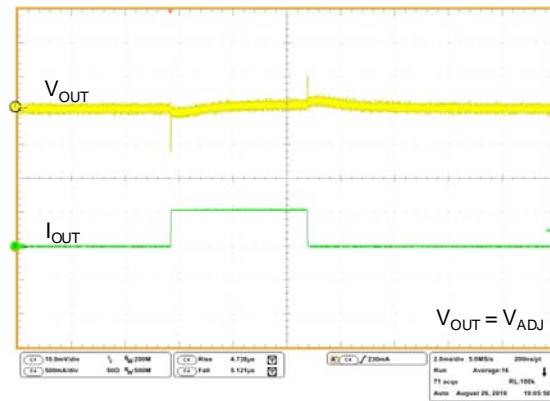

$V_{EN} = V_{IN} = 4.5 V$, I_{OUT} = from 1 to 500 mA, $t_{rise} = t_{fall} = 5 \mu s$, $C_{OUT} = 2.2 \mu F$

Figure 21. Startup transient

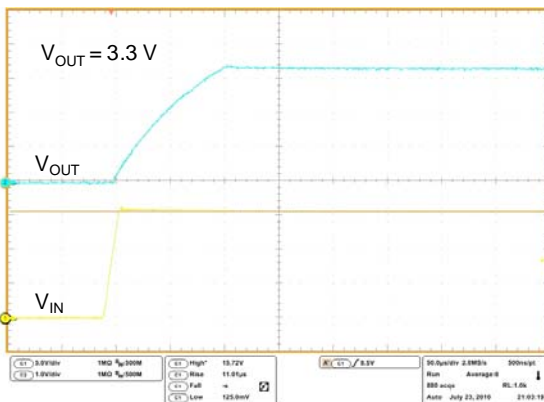

$V_{EN} = V_{IN}$ = from 0 to 16 V, $I_{OUT} = 10 mA$, $t_{rise} = 10 \mu s$, $C_{OUT} = 2.2 \mu F$

Figure 22. Enable transient

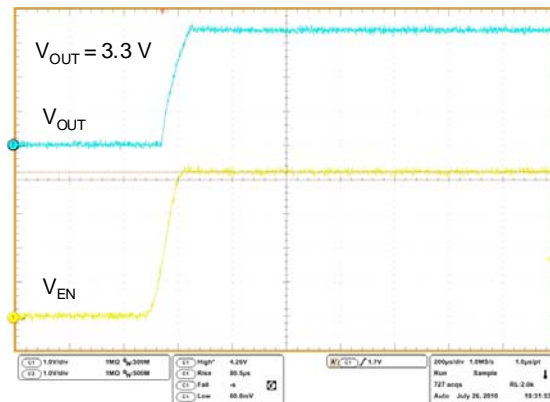

$V_{IN} = 4.3 V$, V_{EN} = from 0 to 4.3 V, $I_{OUT} = 10 mA$, $t_{rise} = 100 \mu s$, $C_{OUT} = 2.2 \mu F$

Figure 23. SVR vs. frequency ($V_{OUT} = 5\text{ V}$)

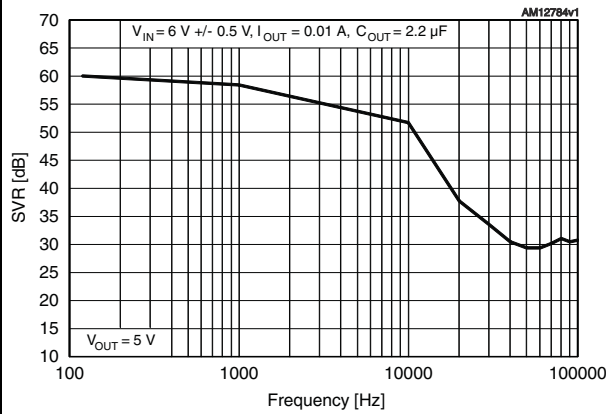

Figure 24. SVR vs. frequency ($V_{OUT} = V_{ADJ}$)

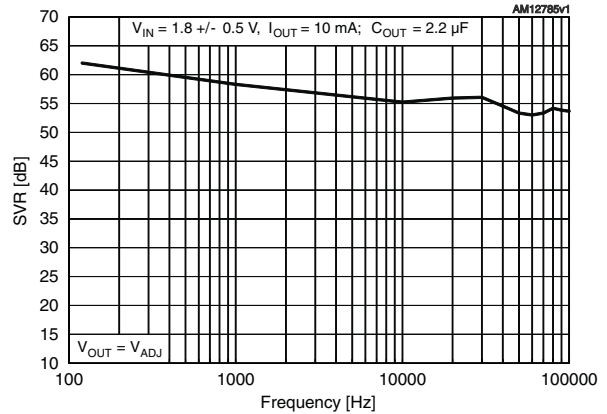

Figure 25. Stability plane adj (C_{OUT} , ESR)

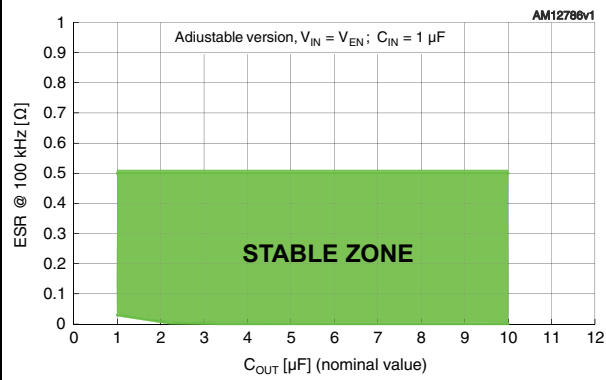
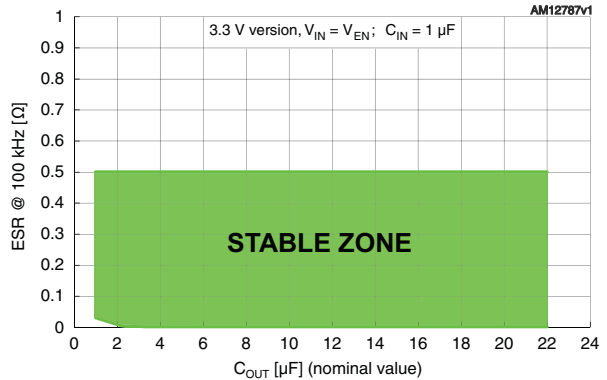

Figure 26. Stability plane 3.3 V (C_{OUT} , ESR)



8 Package information

In order to meet environmental requirements, ST offers these devices in different grades of ECOPACK® packages, depending on their level of environmental compliance. ECOPACK specifications, grade definitions and product status are available at: www.st.com. ECOPACK is an ST trademark.

8.1 PPAK package information

Figure 27. PPAK package outline

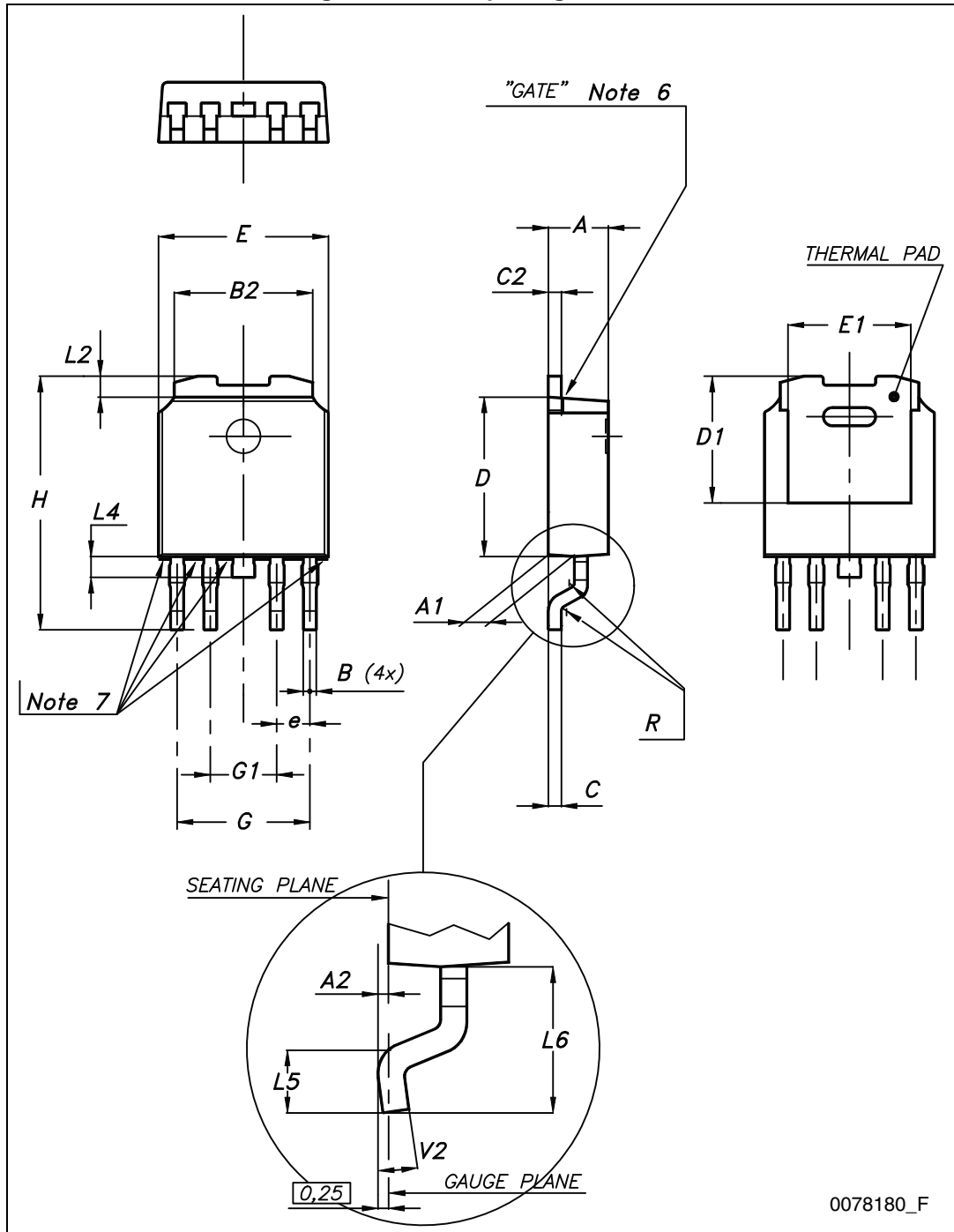

0078180_F

Table 7. PPAK mechanical data

| Dim. | mm | | |
|------|------|------|------|
| | Min. | Typ. | Max. |
| A | 2.2 | | 2.4 |
| A1 | 0.9 | | 1.1 |
| A2 | 0.03 | | 0.23 |
| B | 0.4 | | 0.6 |
| B2 | 5.2 | | 5.4 |
| C | 0.45 | | 0.6 |
| C2 | 0.48 | | 0.6 |
| D | 6 | | 6.2 |
| D1 | | 5.1 | |
| E | 6.4 | | 6.6 |
| E1 | | 4.7 | |
| e | | 1.27 | |
| G | 4.9 | | 5.25 |
| G1 | 2.38 | | 2.7 |
| H | 9.35 | | 10.1 |
| L2 | | 0.8 | 1 |
| L4 | 0.6 | | 1 |
| L5 | 1 | | |
| L6 | | 2.8 | |
| R | | 0.20 | |
| V2 | 0° | | 8° |

8.2 DPAK package information

Figure 28. DPAK package outline

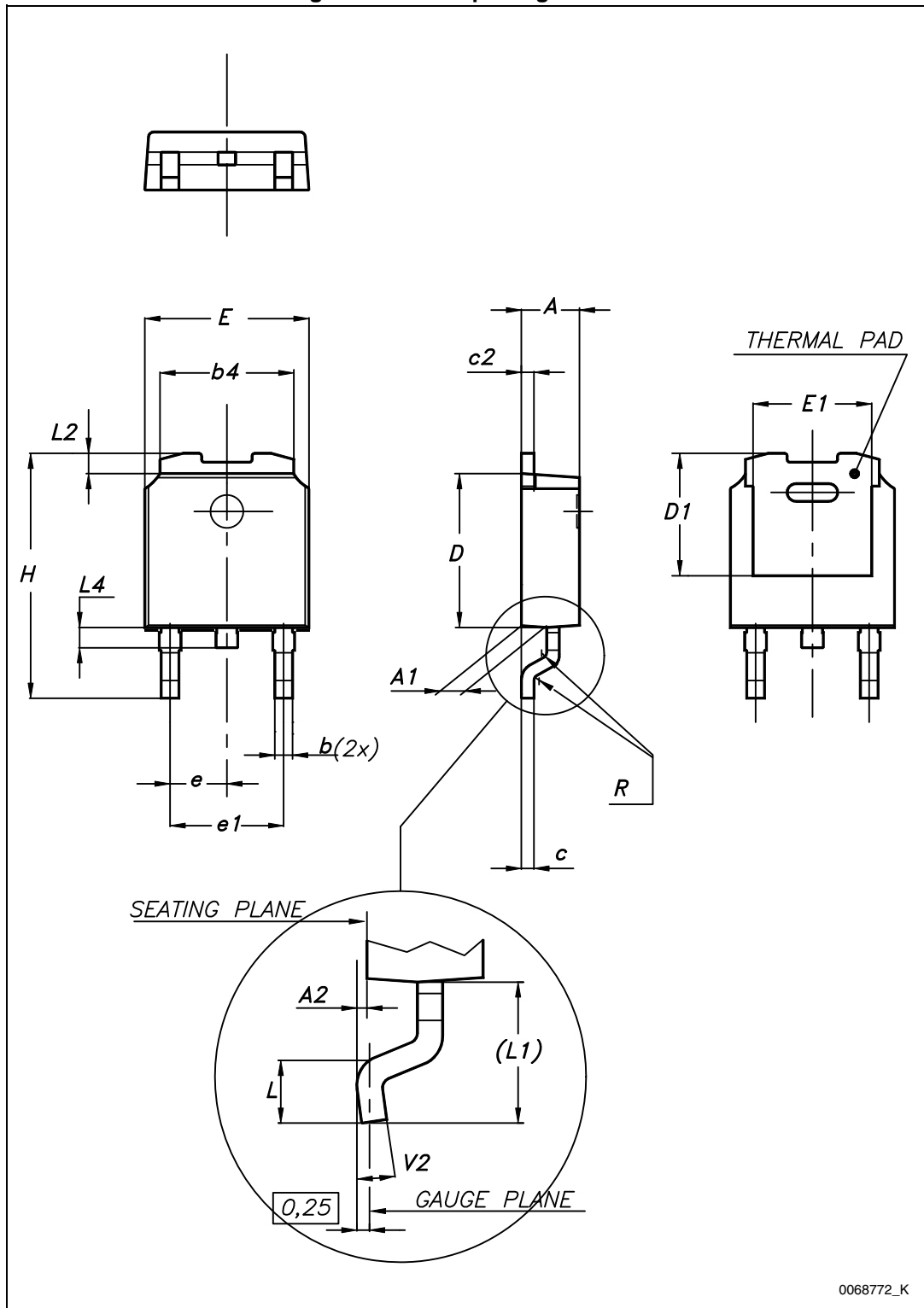

0068772_K

Table 8. DPAK mechanical data

| Dim. | mm | | |
|------|------|------|-------|
| | Min. | Typ. | Max. |
| A | 2.20 | | 2.40 |
| A1 | 0.90 | | 1.10 |
| A2 | 0.03 | | 0.23 |
| b | 0.64 | | 0.90 |
| b4 | 5.20 | | 5.40 |
| c | 0.45 | | 0.60 |
| c2 | 0.48 | | 0.60 |
| D | 6.00 | | 6.20 |
| D1 | | 5.10 | |
| E | 6.40 | | 6.60 |
| E1 | | 4.70 | |
| e | | 2.28 | |
| e1 | 4.40 | | 4.60 |
| H | 9.35 | | 10.10 |
| L | 1.00 | | 1.50 |
| (L1) | | 2.80 | |
| L2 | | 0.80 | |
| L4 | 0.60 | | 1.00 |
| R | | 0.20 | |
| V2 | 0° | | 8° |

Figure 29. DPAK recommended footprint (a)

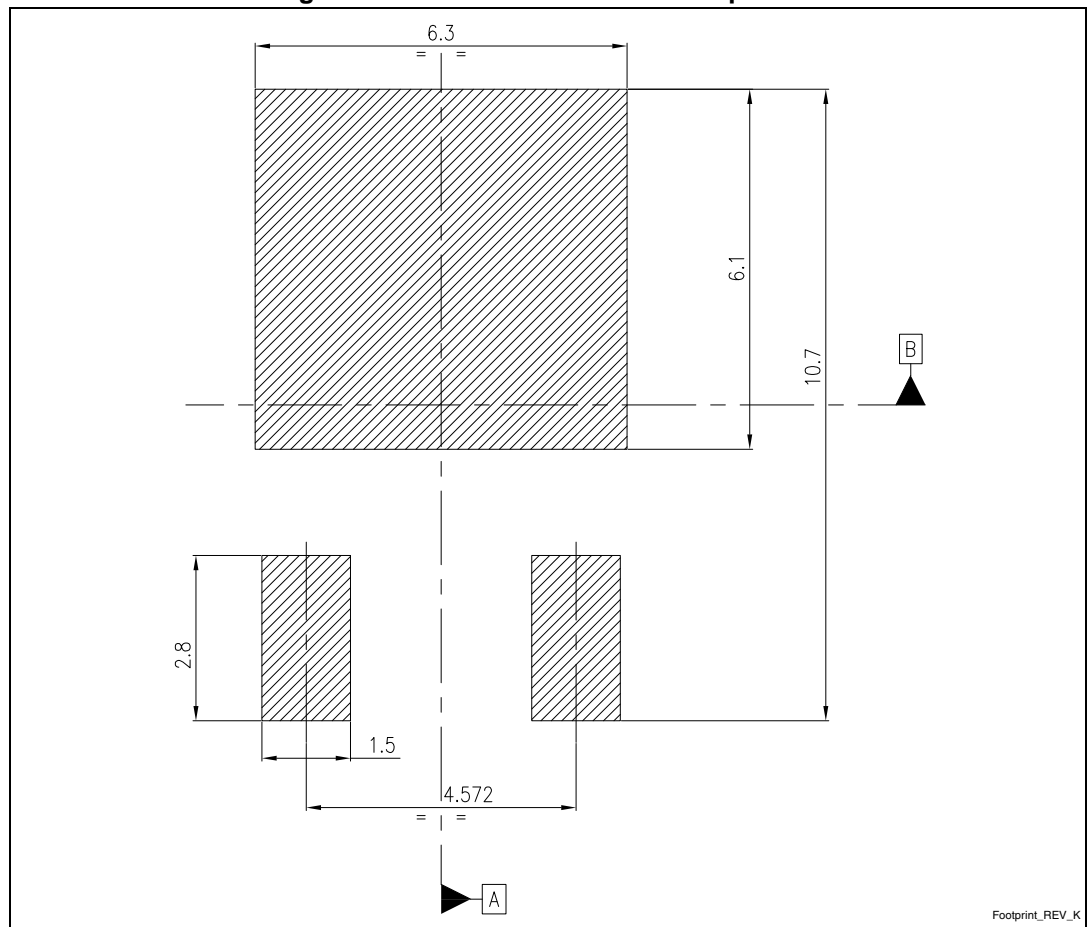

a. All dimensions are in millimeters.

8.3 PPAK and DPAK packing information

Figure 30. PPAK and DPAK tape outline

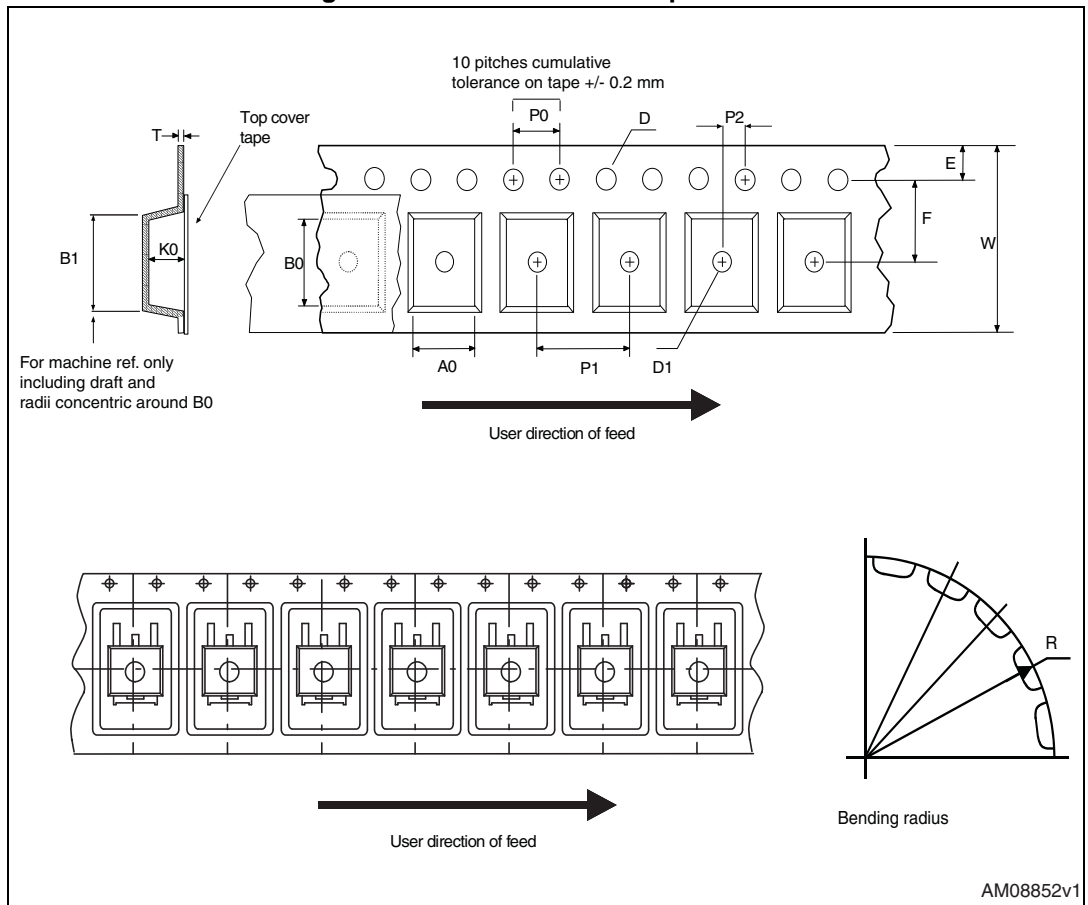
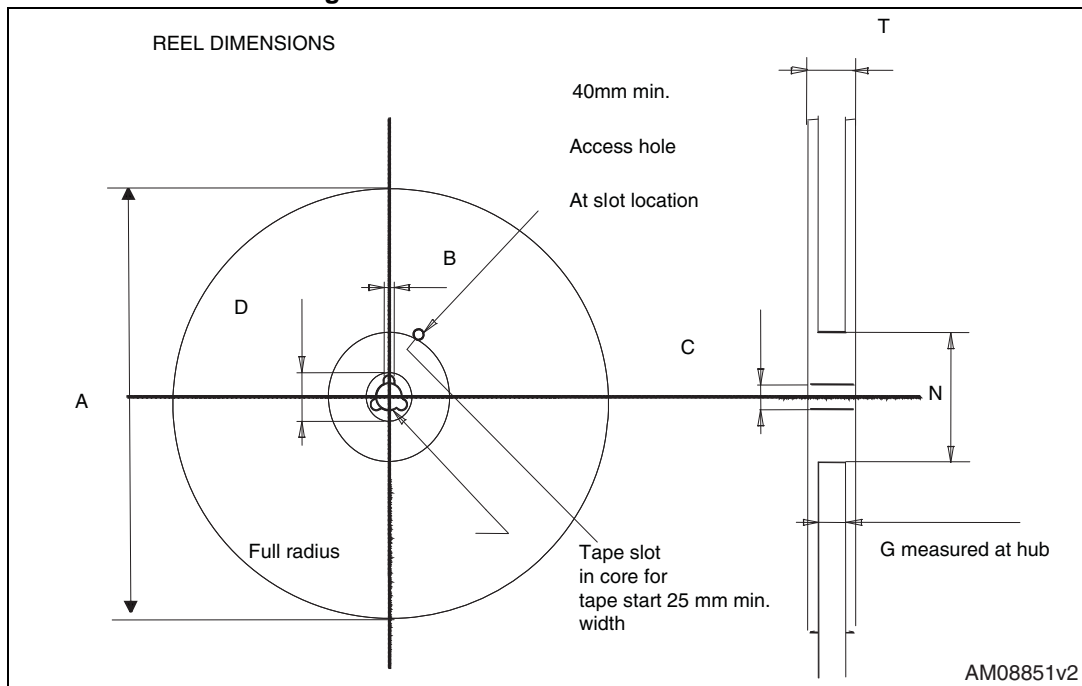

Figure 31. PPAK and DPAK reel outline



AM08851v2

Table 9. PPAK and DPAK tape and reel mechanical data

| Tape | | | Reel | | |
|------|------|------|------|-----------|------|
| Dim. | mm | | Dim. | mm | |
| | Min. | Max. | | Min. | Max. |
| A0 | 6.8 | 7 | A | | 330 |
| B0 | 10.4 | 10.6 | B | 1.5 | |
| B1 | | 12.1 | C | 12.8 | 13.2 |
| D | 1.5 | 1.6 | D | 20.2 | |
| D1 | 1.5 | | G | 16.4 | 18.4 |
| E | 1.65 | 1.85 | N | 50 | |
| F | 7.4 | 7.6 | T | | 22.4 |
| K0 | 2.55 | 2.75 | | | |
| P0 | 3.9 | 4.1 | | Base qty. | 2500 |
| P1 | 7.9 | 8.1 | | Bulk qty. | 2500 |
| P2 | 1.9 | 2.1 | | | |
| R | 40 | | | | |
| T | 0.25 | 0.35 | | | |
| W | 15.7 | 16.3 | | | |

8.4 DFN6 (2 x 2 mm) package information

Figure 32. DFN6 (2 x 2 mm) package outline

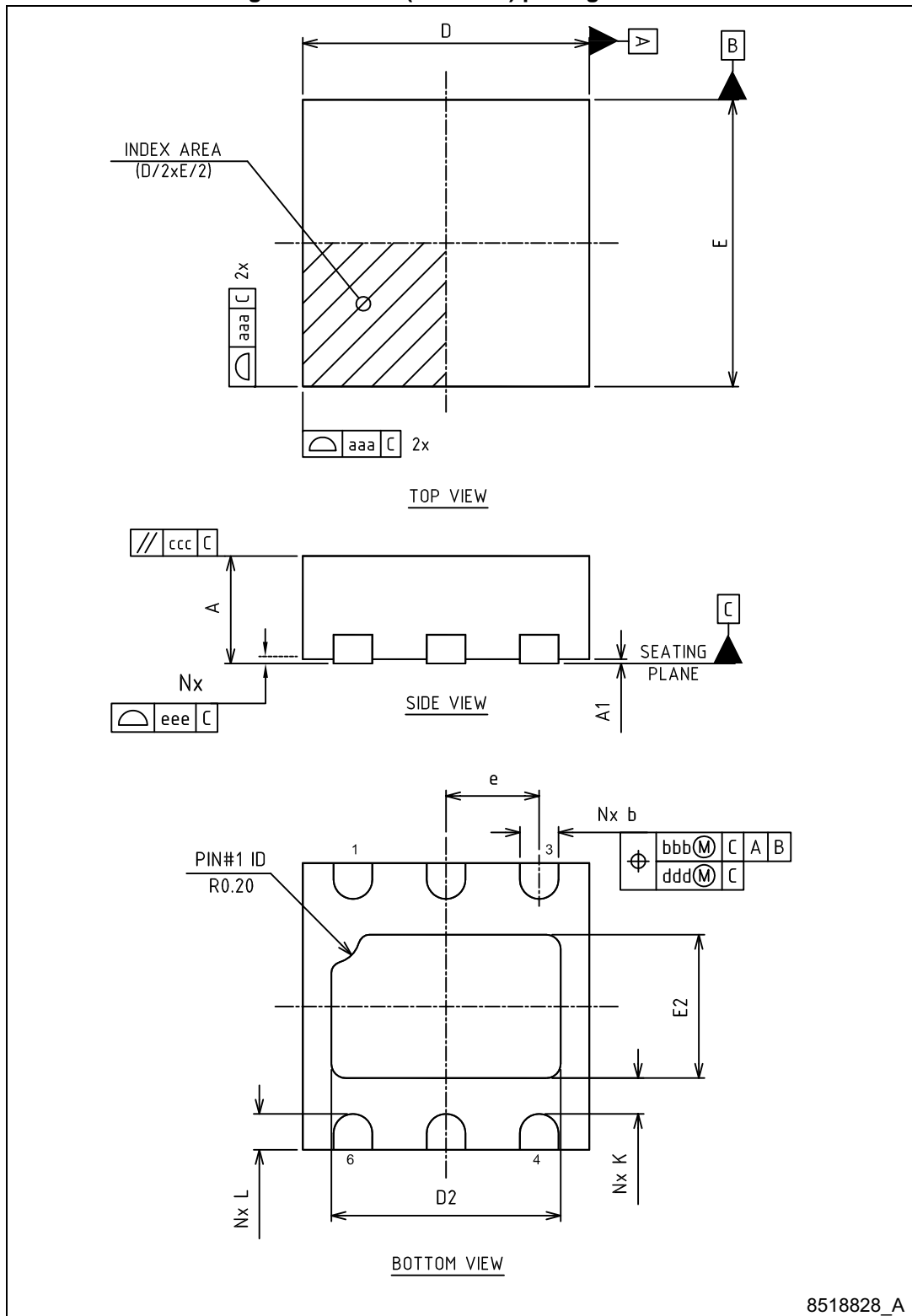

Table 10. DFN6 (2 x 2 mm) mechanical data

| Dim. | mm | | |
|------|----------|------|------|
| | Min. | Typ. | Max. |
| A | 0.80 | 0.90 | 1.00 |
| A1 | 0.00 | 0.02 | 0.05 |
| b | 0.25 | 0.30 | 0.35 |
| D | 2.00 BSC | | |
| E | 2.00 BSC | | |
| e | 0.65 BSC | | |
| D2 | 1.45 | 1.60 | 1.70 |
| E2 | 0.85 | 1.00 | 1.10 |
| L | 0.20 | 0.25 | 0.30 |
| K | 0.15 | | |
| aaa | 0.05 | | |
| bbb | 0.10 | | |
| ccc | 0.10 | | |
| ddd | 0.05 | | |
| eee | 0.08 | | |
| N | 6 | | |

8.5 DFN6 (2 x 2 mm) packing information

Figure 34. DFN6 (2 x 2 mm) tape and reel outline

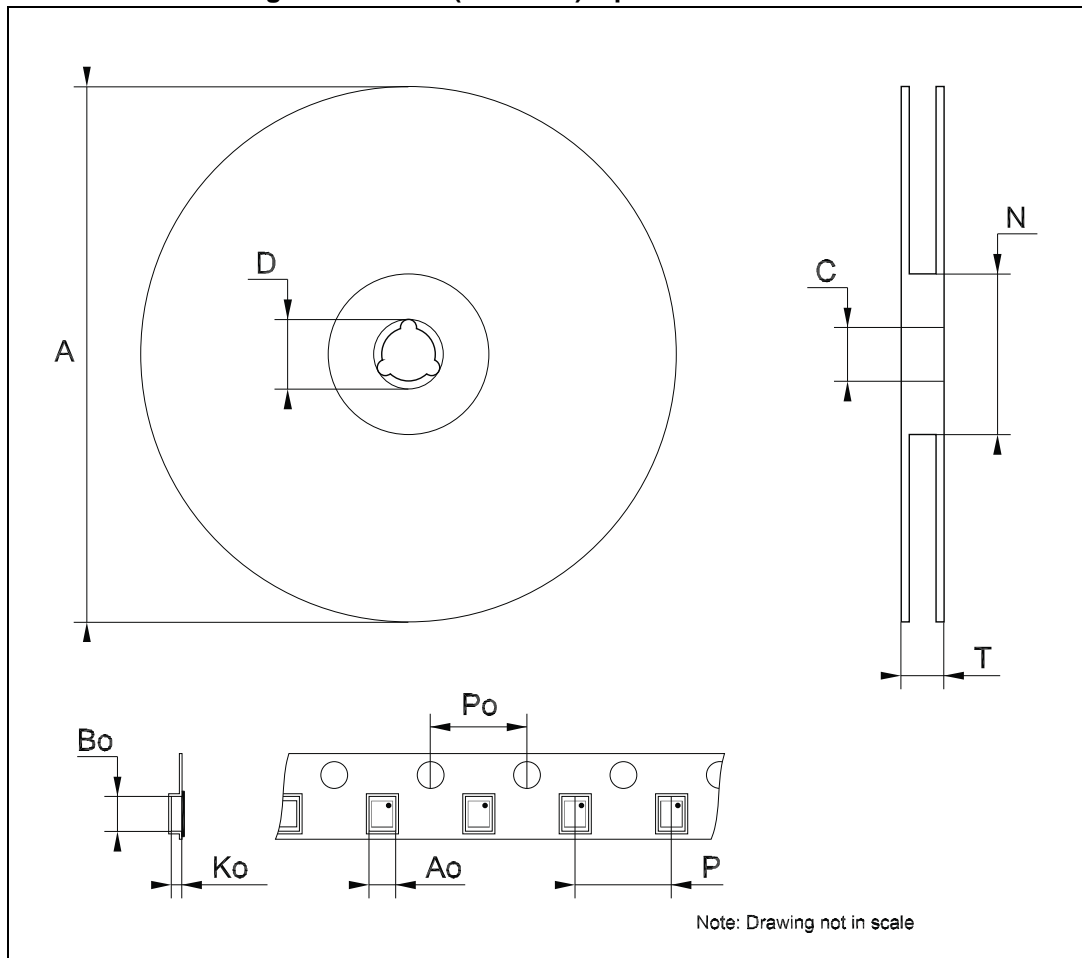

Table 11. DFN6 (2 x 2 mm) tape and reel mechanical data

| Dim. | mm | | |
|------|------|------|------|
| | Min. | Typ. | Max. |
| A | | | 180 |
| C | 12.8 | | 13.2 |
| D | 20.2 | | |
| N | 60 | | |
| T | | | 14.4 |
| Ao | | 2.4 | |
| Bo | | 2.4 | |
| Ko | | 1.3 | |
| Po | | 4 | |
| P | | 4 | |

8.6 DFN6 (3 x 3 mm) package information

Figure 35. DFN6 (3 x 3 mm) package outline

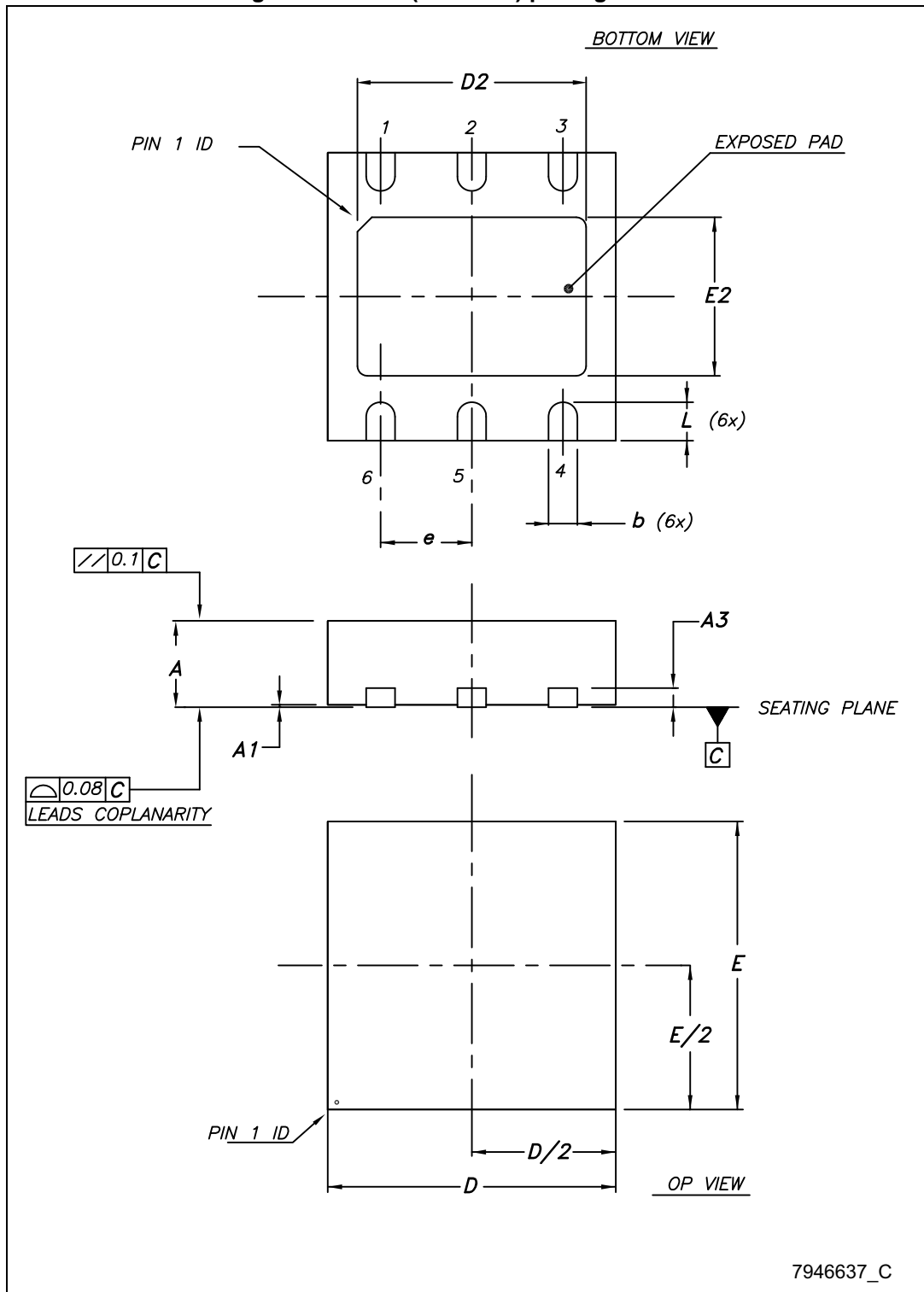
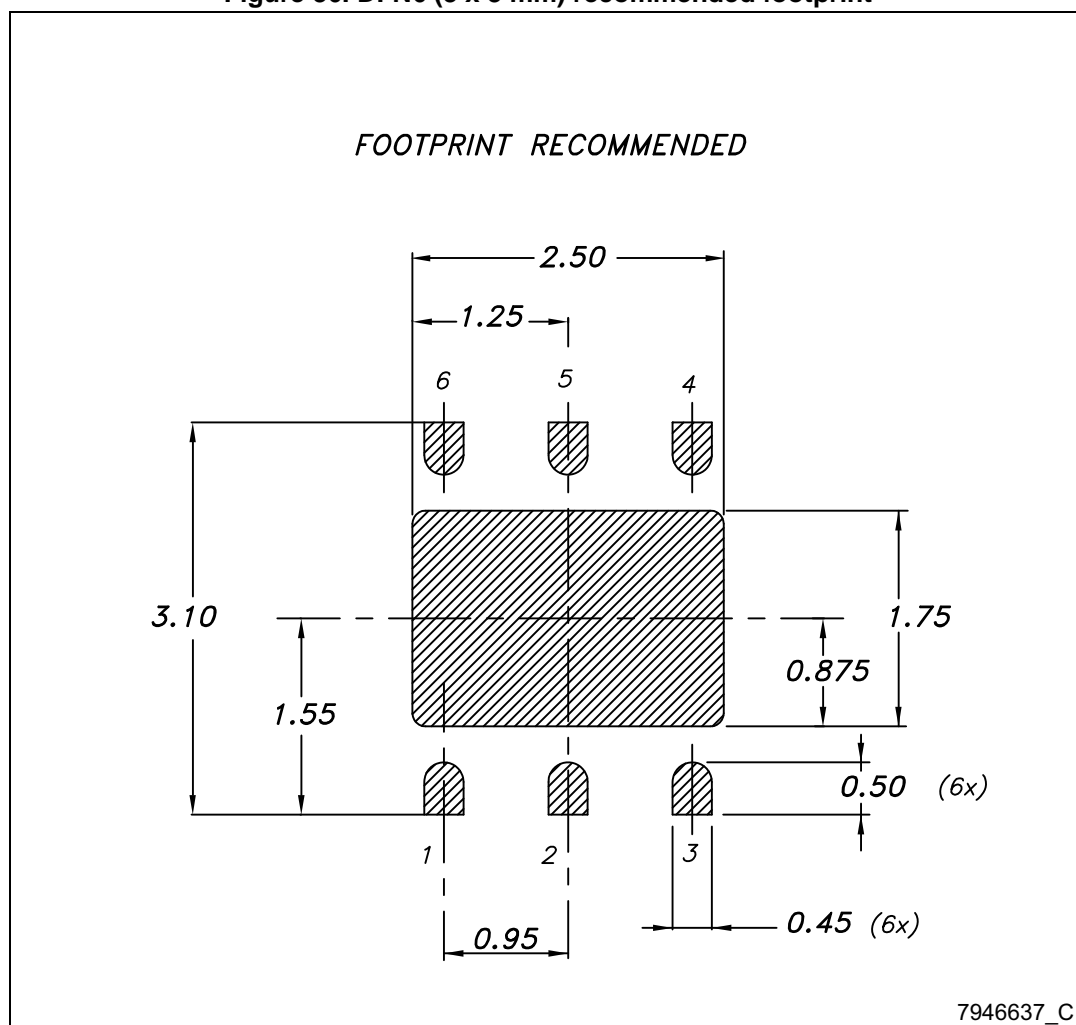

Table 12. DFN6 (3 x 3 mm) mechanical data

| Dim. | mm | | |
|------|------|------|------|
| | Min. | Typ. | Max. |
| A | 0.80 | | 1 |
| A1 | 0 | 0.02 | 0.05 |
| A3 | | 0.20 | |
| b | 0.23 | | 0.45 |
| D | 2.90 | 3 | 3.10 |
| D2 | 2.23 | | 2.50 |
| E | 2.90 | 3 | 3.10 |
| E2 | 1.50 | | 1.75 |
| e | | 0.95 | |
| L | 0.30 | 0.40 | 0.50 |

Figure 36. DFN6 (3 x 3 mm) recommended footprint



8.7 DFN6 (3 x 3 mm) packing information

Figure 37. DFN6 (3 x 3 mm) tape outline

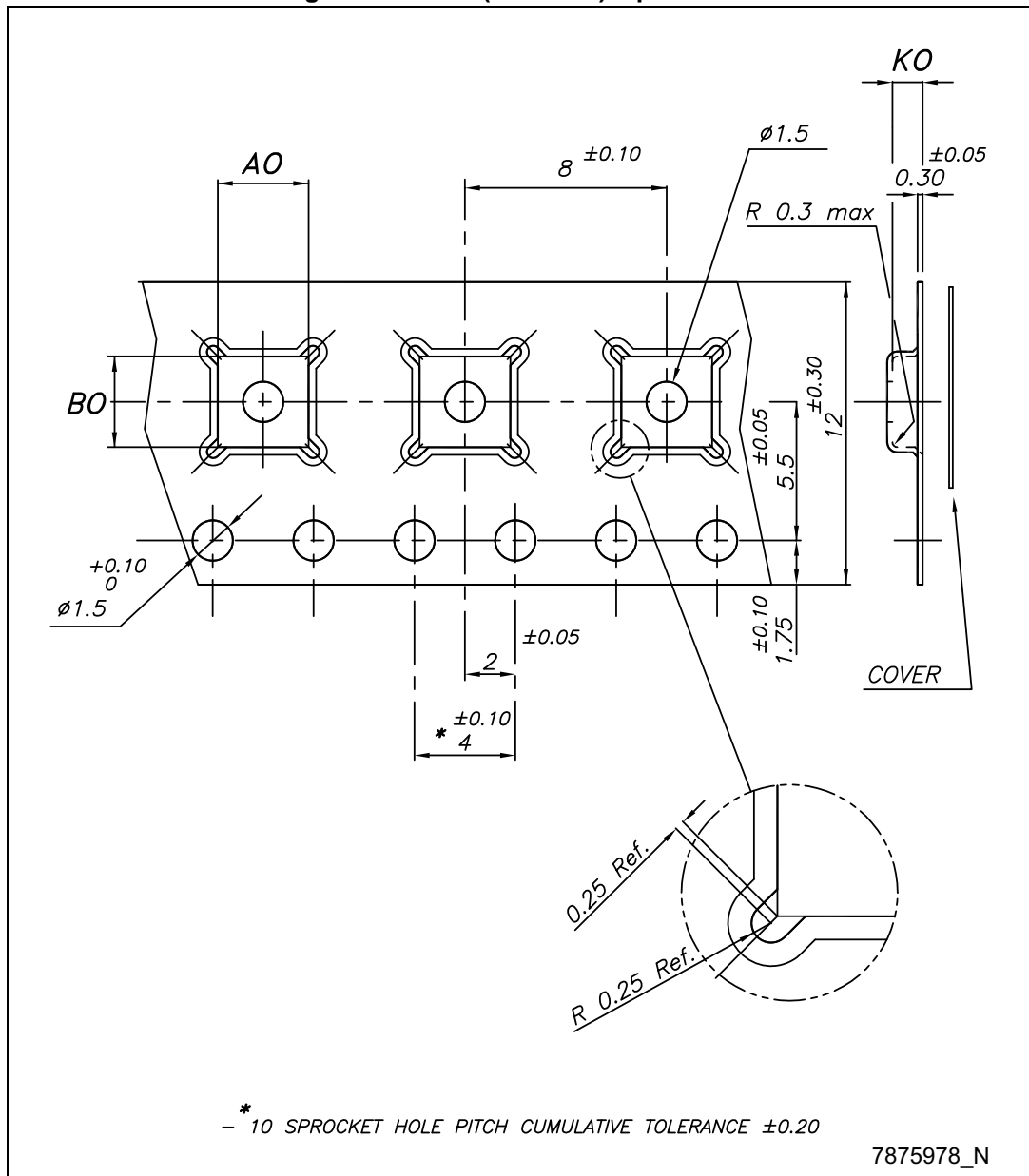

7875978_N

Figure 38. DFN6 (3 x 3 mm) reel outline

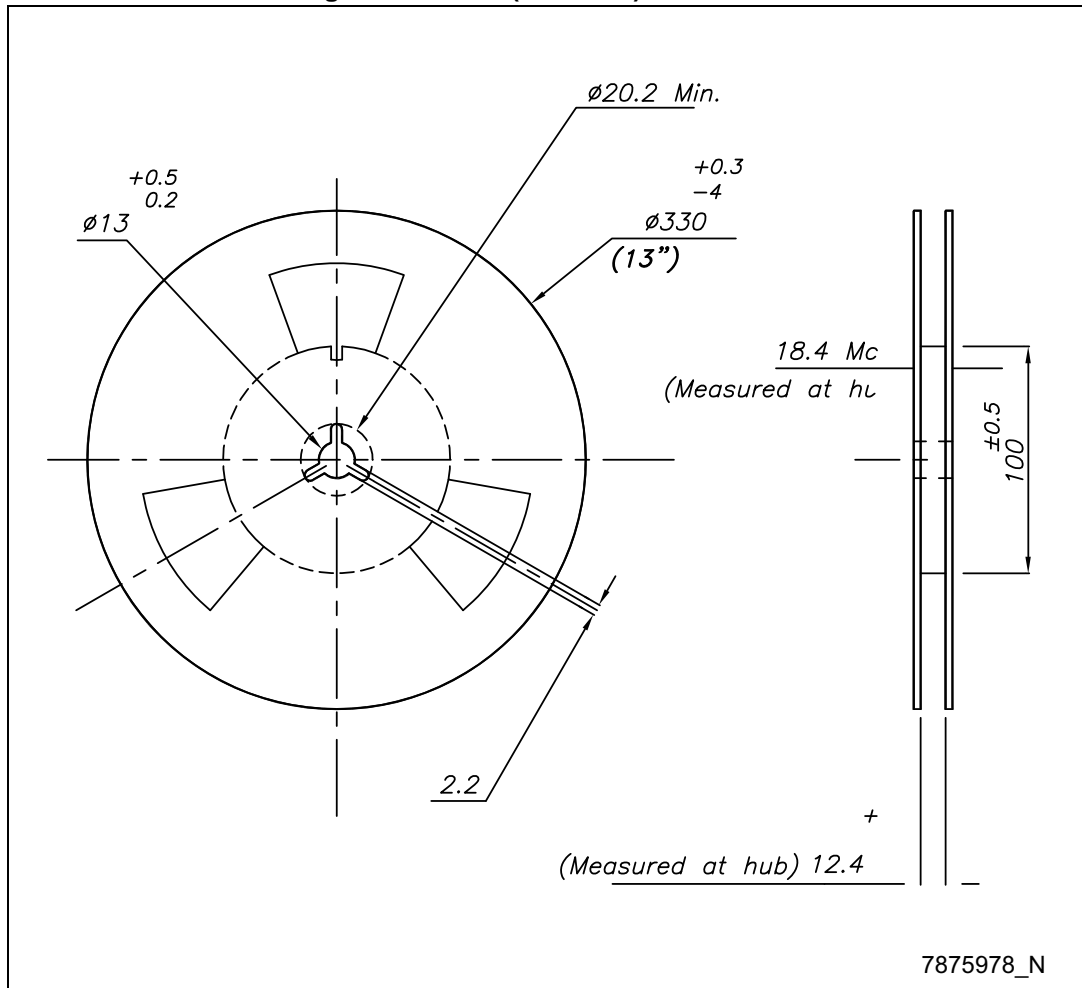

Table 13. DFN6 (3 x 3 mm) tape and reel mechanical data

| Dim. | mm | | |
|------|------|------|------|
| | Min. | Typ. | Max. |
| A0 | 3.20 | 3.30 | 3.40 |
| B0 | 3.20 | 3.30 | 3.40 |
| K0 | 1 | 1.10 | 1.20 |

9 Order code

Table 14. Order codes

| Order code | Packages | Output voltages |
|-------------|----------|-----------------------|
| LDFMPT-TR | PPAK | Adjustable from 0.8 V |
| LDFMPUR | DFN6-3x3 | |
| LDFMPVR | DFN6-2x2 | |
| LDFM50DT-TR | DPAK | 5 V |
| LDFM50PT-TR | PPAK | |

10 Revision history

Table 15. Document revision history

| Date | Revision | Changes |
|-------------|----------|---|
| 28-Aug-2012 | 1 | Initial release. |
| 22-Nov-2013 | 2 | Part numbers LDFM and LDFM50 have been unified under LDFM. Updated the Features and the Description in cover page. Cancelled Table1: Device summary. Updated Section 2: Pin configuration , Section 3: Typical application , Section 4: Absolute maximum ratings , Section 5: Electrical characteristics and Section 8: Package information . Added Section 8.7: DFN6 (3 x 3 mm) packing information and Section 9: Order code . Minor text changes. |
| 15-Jun-2015 | 3 | Updated Table 5: Electrical characteristics for LDFM (fixed versions) and Table 6: Electrical characteristics for LDFM (adjustable version) . Minor text changes. |

IMPORTANT NOTICE – PLEASE READ CAREFULLY

STMicroelectronics NV and its subsidiaries ("ST") reserve the right to make changes, corrections, enhancements, modifications, and improvements to ST products and/or to this document at any time without notice. Purchasers should obtain the latest relevant information on ST products before placing orders. ST products are sold pursuant to ST's terms and conditions of sale in place at the time of order acknowledgement.

Purchasers are solely responsible for the choice, selection, and use of ST products and ST assumes no liability for application assistance or the design of Purchasers' products.

No license, express or implied, to any intellectual property right is granted by ST herein.

Resale of ST products with provisions different from the information set forth herein shall void any warranty granted by ST for such product.

ST and the ST logo are trademarks of ST. All other product or service names are the property of their respective owners.

Information in this document supersedes and replaces information previously supplied in any prior versions of this document.

© 2015 STMicroelectronics – All rights reserved