

BUF16821EVM-USB Evaluation Board and Software Tutorial

This user's guide describes the characteristics, operation, and use of the BUF16821EVM-USB evaluation board. It discusses how to set up and configure the software and hardware, and reviews various aspects of the program operation. Throughout this document, the terms *evaluation board*, *evaluation module*, and *EVM* are synonymous with the BUF16821EVM-USB. This user's guide also includes information regarding operating procedures and input/output connections, an electrical schematic, PCB layout drawings, and a parts list for the EVM.

Contents

1	Overview	2
2	BUF16821EVM-USB Hardware Setup	4
3	BUF16821EVM-USB Software	7
4	BUF16821EVM-USB Software	14
5	BUF16821EVM-USB Software Overview	17
6	Hardware and Schematic	25

List of Figures

1	Hardware Included with BUF16821EVM-USB Kit	3
2	BUF16821EVM-USB Hardware Setup	4
3	BUF16821EVM-USB Board Block Diagram	5
4	USB_DIG_Platform Block Diagram	7
5	Typical Hardware Connections for BUF16821EVM-USB	8
6	Connecting External Power to the EVM	9
7	Connecting the USB Cable to the USB_DIG_Platform	10
8	Confirmation of USB_DIG_Platform Driver Installation	10
9	BUF16821EVM-USB Default Jumper Settings	11
10	BUF16821EVM-USB Software Installation	15
11	BUF16821EVM-USB License Agreements	16
12	BUF16821EVM-USB Software Installation Progress	16
13	BUF16821EVM-USB Software <i>About</i> Button	17
14	BUF16821EVM-USB Software: Communication Error with the USB_DIG_Platform	17
15	JMP5 Setting For Logic '1'	18
16	JMP5 Setting for Logic '0'	18
17	Measuring and Entering Power-Supply Voltage	19
18	Auto Write Feature Enabled	20
19	Save to File Dialog Box Button and Window	21
20	File Format of Saved Data	22
21	Load From File Button and Window	23
22	Run Batch Dialog Button and Window	24

PowerPAD is a trademark of Texas Instruments.
 Microsoft, Windows are registered trademarks of Microsoft Corporation.
 I²C is a trademark of NXP Semiconductors.
 WinZIP is a registered trademark of WinZip International LLC.
 All other trademarks are the property of their respective owners.

23	Control Panel Button and Window	25
24	BUF16821EVM-USB Schematic	26
25	BUF16821EVM-USB PCB Top Layer (Component Side).....	27

1 Overview

The BUF16821 is a programmable gamma-voltage generator and V_{COM} calibrator with integrated two-bank memory. This device offers 16 programmable gamma channels and two programmable V_{COM} channels, making it ideal for 10-bit source TFT-LCD reference drivers. The BUF16821EVM-USB is a platform for evaluating the performance of the [BUF16821](#) under various signal, reference, and supply conditions.

This document gives a general overview of the BUF16821EVM-USB, and provides a general description of the features and functions to be considered while using this evaluation module.

1.1 BUF16821EVM-USB Kit Contents

Table 1 summarizes the contents of the BUF16821EVM-USB kit. Figure 1 shows all of the included hardware. Contact the [Texas Instruments Product Information Center](#) nearest you if any component is missing. It is highly recommended that you also check the [BUF16821 product folder](#) on the TI web site at www.ti.com to verify that you have the latest versions of the related software.

Table 1. BUF16821EVM-USB Kit Contents

Item	Quantity
BUF16821EVM-USB PCB Test Board	1
USB_DIG_Platform PCB	1
USB Cable	1
+6V Power Supply	1
User's Guide CD-ROM	1

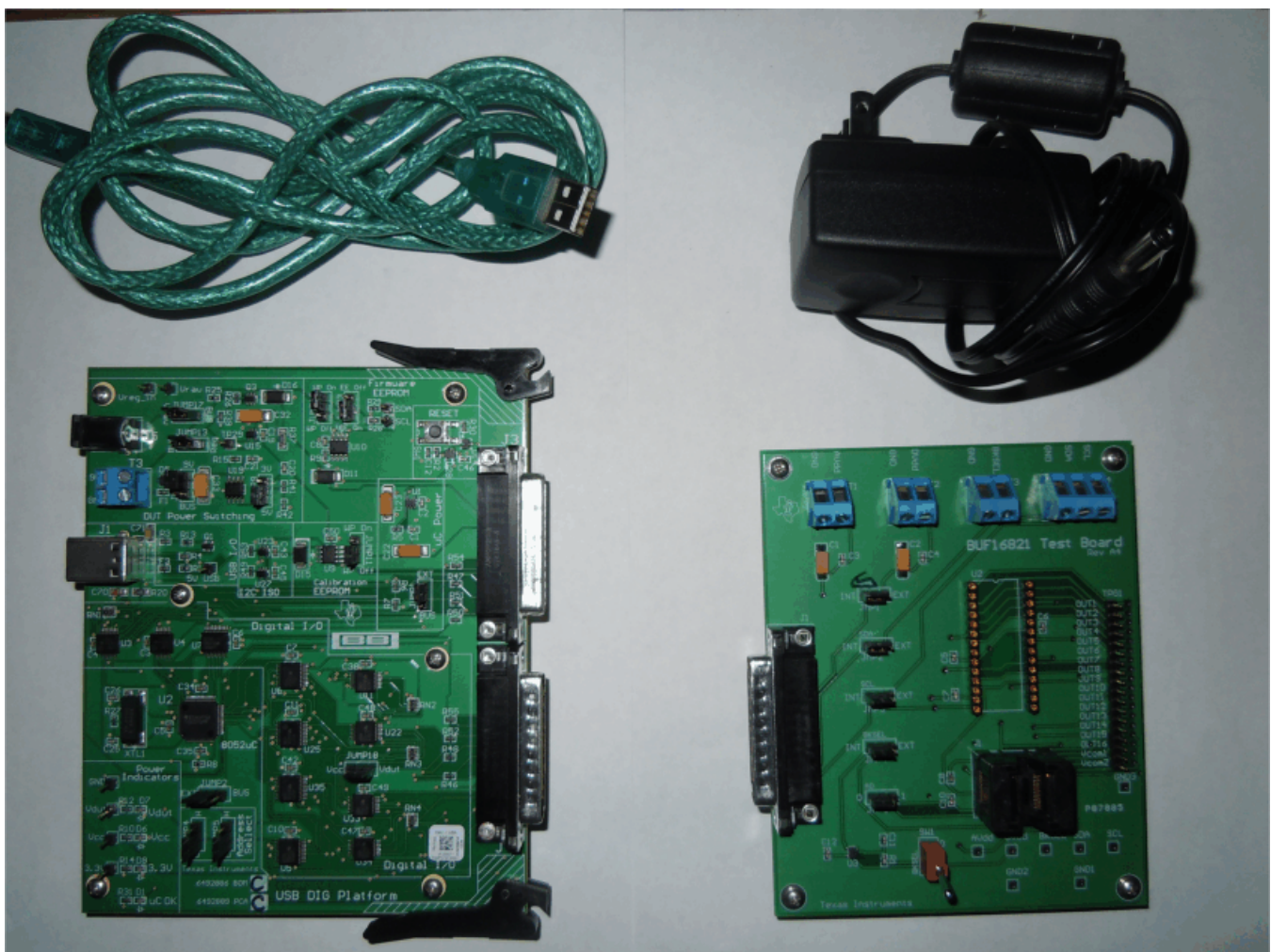

Figure 1. Hardware Included with BUF16821EVM-USB Kit

1.2 Related Documentation from Texas Instruments

The following documents provide information regarding Texas Instruments' integrated circuits used in the assembly of the BUF16821EVM-USB. This user's guide is available from the TI web site under literature number **SBOU106**. Any letter appended to the literature number corresponds to the document revision that is current at the time of the writing of this document. Newer revisions may be available from the [TI web site](#), or call the Texas Instruments' Literature Response Center at (800) 477-8924 or the Product Information Center at (972) 644-5580. When ordering, identify the document by both title and literature number.

Table 2. Related Documentation

Document	Literature Number
BUF16821 Product Data Sheet	SBOS428B
USB_DIG_Platform User Guide	SBOU058

2 BUF16821EVM-USB Hardware Setup

Figure 2 shows the system setup for the BUF16821EVM-USB. The PC runs software that communicates with the USB_DIG_Platform. The USB_DIG_Platform generates the analog and digital signals used to communicate with the 16821EVM-USB. Connectors on the BUF16821EVM-USB test board allow the user to connect to the system under test conditions and monitor the power, current, and voltage.

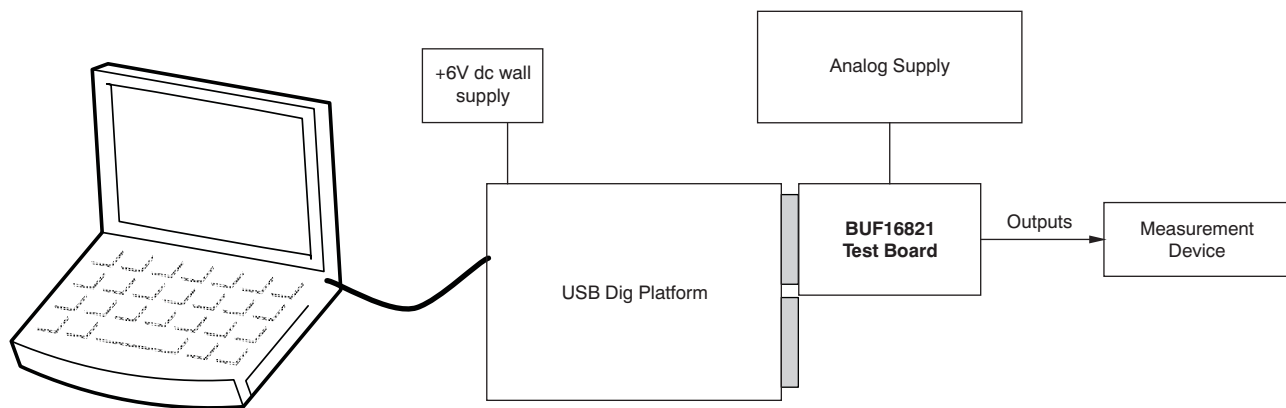

Figure 2. BUF16821EVM-USB Hardware Setup

2.1 Theory of Operation for BUF16821 Hardware

A block diagram of the BUF16821 test board hardware setup is shown in Figure 3. The functionality of the PCB is such that it provides connections to the I²C™ interface and general-purpose inputs/outputs (GPIOs) on the USB_DIG_Platform board. It also provides connection points for external connections of the shunt voltage, bus voltage, and ground.

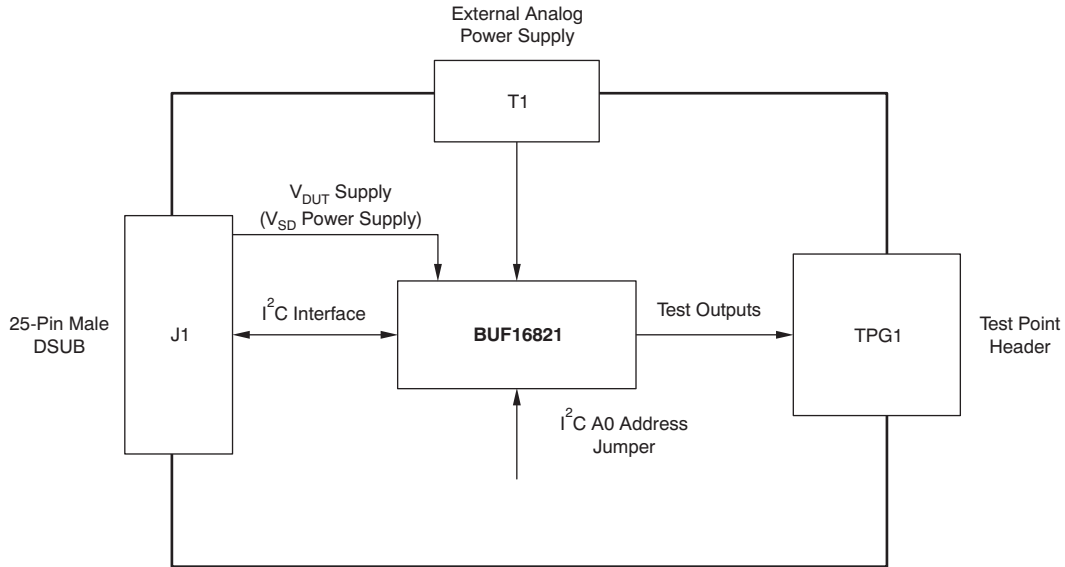

Figure 3. BUF16821EVM-USB Board Block Diagram

2.2 Signal Definitions of J1 (25-Pin Male DSUB)

Table 3 lists the various signals connected to J1 on the BUF16821EVM-USB test board.

Table 3. Signal Definition of J1 (25-Pin Male DSUB) on BUF16821EVM-USB Board

Pin on J1	Signal	BUF16821 Pin
1	N/C	No connection
2	N/C	No connection
3	N/C	No connection
4	N/C	No connection
5	N/C	No connection
6	N/C	No connection
7	N/C	No connection
8	N/C	No connection
9	I2C_SCK	No connection
10	I2C_SDA2	No connection
11	N/C	No connection
12	I2C_SCK_ISO	I ² C clock signal (SCL) channel 1; can be disconnected using a switch
13	I2C_SDA_ISO	I ² C data signal (SDA) channel 1; can be disconnected using a switch
14	N/C	No connection
15	N/C	No connection
16	N/C	No connection
17	V _{DUT}	Switched 3V/5V power. Note that when power is switched off, digital I/O is also switched off.
18	V _{CC}	No connection
19	N/C	No connection
20	N/C	No connection
21	GND	Common ground connection
22	SPI_SCK	No connection
23	SPI_CS1	No connection
24	SPI_DOUT1	No connection
25	SPI_DIN1	No connection

2.2.1 Theory of Operation for USB_DIG_Platform

Figure 4 shows the block diagram for the USB_DIG_Platform. This platform is a general-purpose data acquisition system that is used on several different Texas Instruments evaluation modules. The details of its operation are included in a separate document, [SBOU058](#) (available for download at [www.ti.com](#)). The block diagram shown in Figure 4 gives a brief overview of the platform. The primary control device on the USB_DIG_Platform is the [TUSB3210](#).

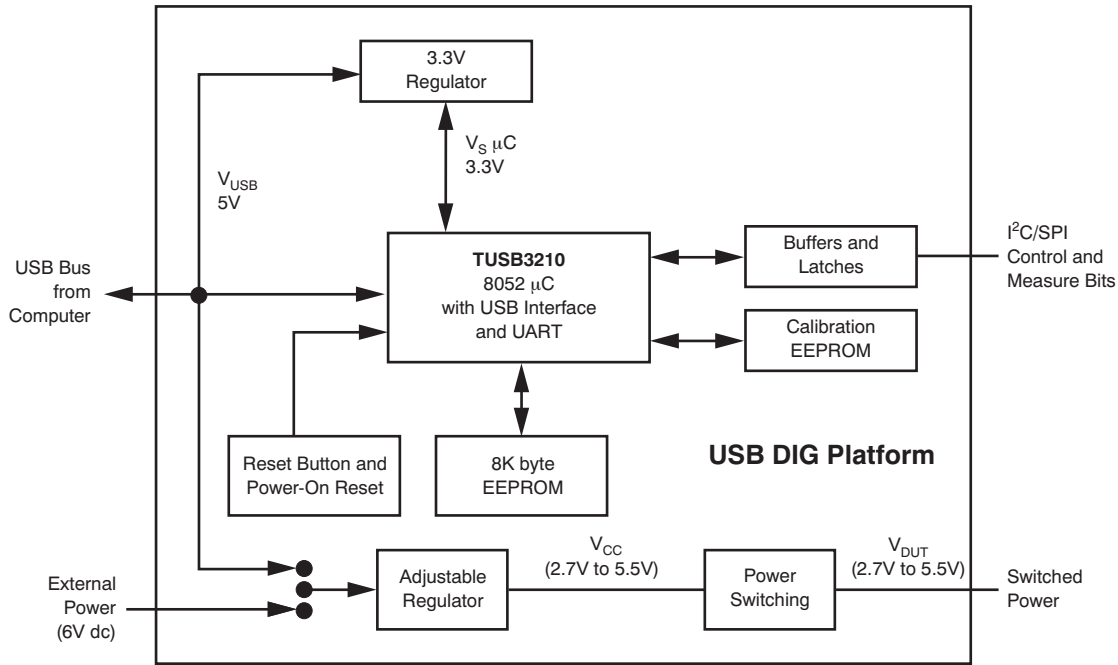

Figure 4. USB_DIG_Platform Block Diagram

3 BUF16821EVM-USB Software

The BUF16821EVM-USB hardware overview involves connecting the two PCBs of the EVM together, applying power, connecting the USB cable, and setting the jumpers. This section presents the details of this procedure.

3.1 Electrostatic Discharge Warning

CAUTION

Many of the components on the BUF16821EVM-USB are susceptible to damage by electrostatic discharge (ESD). Customers are advised to observe proper ESD handling precautions when unpacking and handling the EVM, including the use of a grounded wrist strap at an approved ESD workstation.

3.2 Typical Hardware Connections

To set up the BUF16821EVM-USB hardware, connect the two PCBs of the EVM together (that is, the BUF16821 Test Board and USB_DIG_Platform board) via a 25-pin DSUB connector, and apply a power source. The external connections may be the real-world system that the BUF16821 will be incorporated into. Figure 5 illustrates the typical hardware connections.

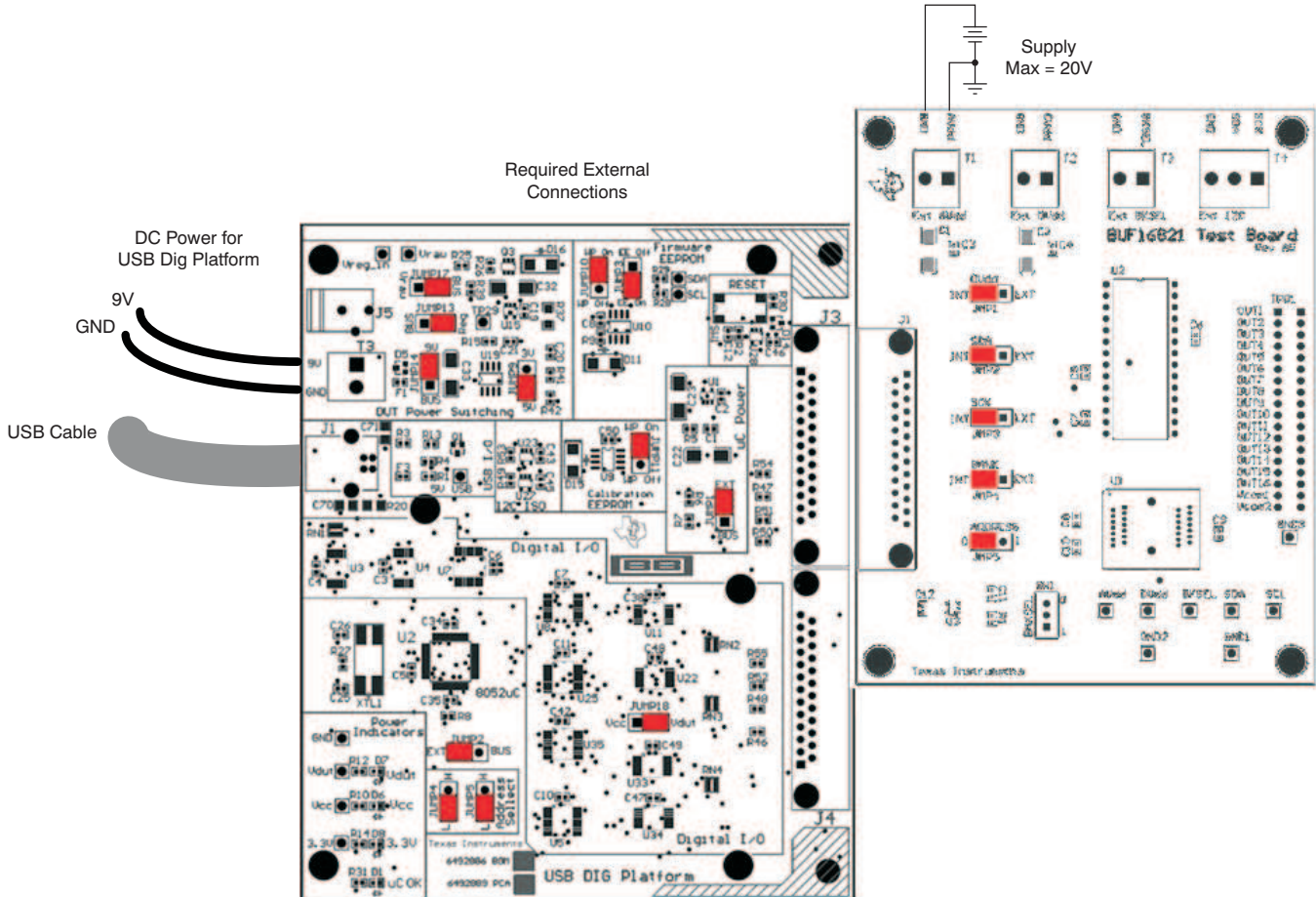

Figure 5. Typical Hardware Connections for BUF16821EVM-USB

3.3 Connecting the Hardware

To connect the two PCBs of the BUF16821EVM-USB together, gently push on both sides of the DSUB connectors (as shown in [Figure 6](#)). Note that the USB_DIG_Platform board has two DSUB connectors; either may be used. Make sure that the two connectors are completely pushed together; loose connections may cause intermittent operation.

3.4 Connecting Power

After the two parts of the BUF16821EVM-USB are conjoined, connect the power to the USB_DIG_Platform board, as [Figure 6](#) shows. Always connect power before connecting the USB cable. If you connect the USB cable before connecting the power, the computer will attempt to communicate with an unpowered device that will not be able to respond.

NOTE: It is always necessary to connect the power to the USB_DIG_Platform board before connecting the USB cable.

In addition, the BUF16821EVM-USB also requires an external power source. This source is not included with the kit. Its voltage may differ depending on your specific testing needs. The source will be used to provide dc supply voltage to terminal T1 on the BUF16821EVM-USB.

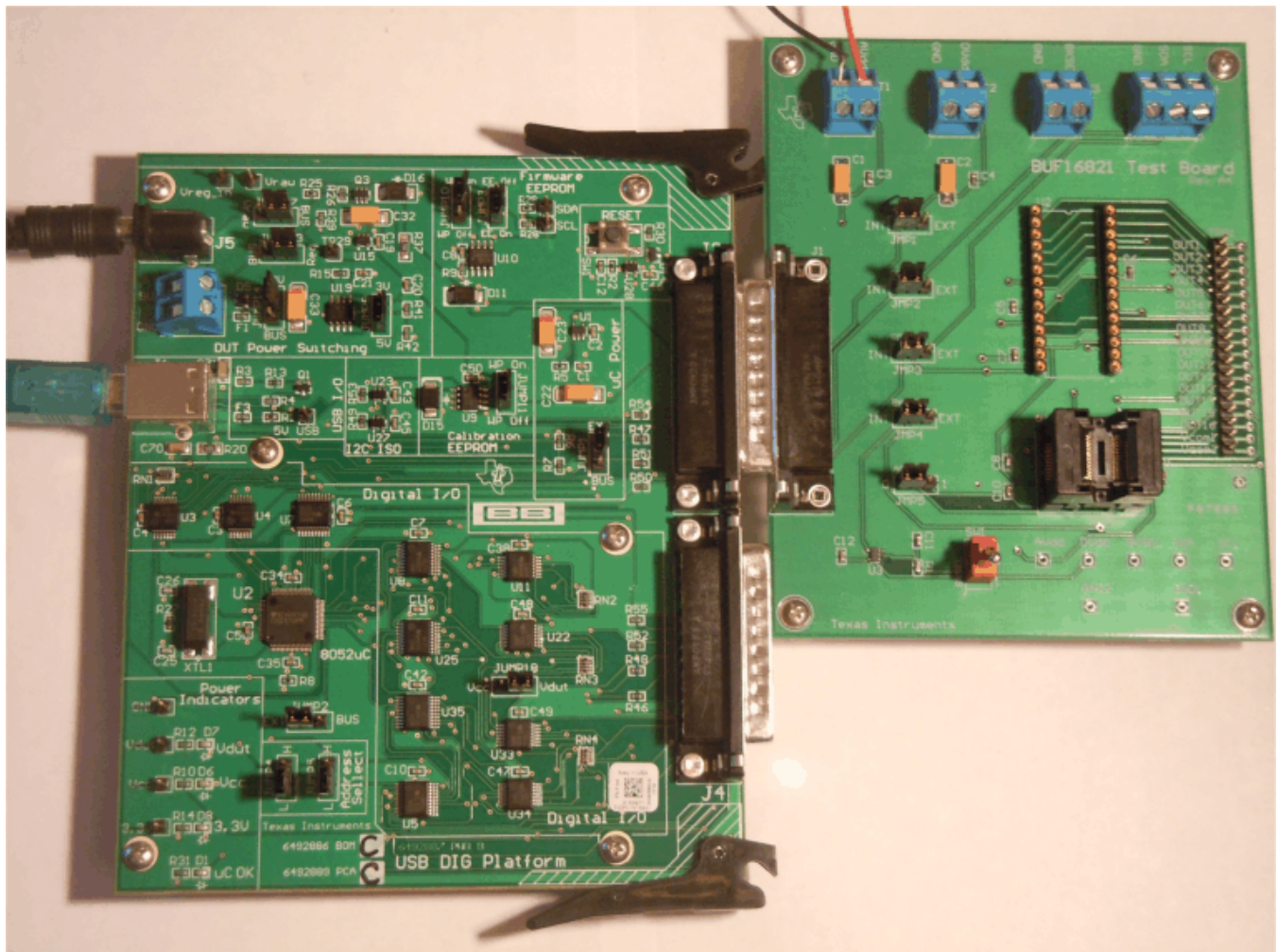

Figure 6. Connecting External Power to the EVM

3.5 Connecting the USB Cable to the USB_DIG_Platform

Once power is connected, the USB cable must be connected to the USB_DIG_Platform, as shown in [Figure 7](#). Note that the BUF16821EVM-USB test board and the USB_DIG_Platform board must each be powered on before connecting the USB cable. Typically, the computer will respond with a *Found New Hardware, USB Device* pop-up dialog. The pop-up window typically changes to *Found New Hardware, USB Human Interface Device*. This pop-up indicates that the device is ready to be used. The USB_DIG_Platform uses the human interface device drivers that are part of the Microsoft® Windows® operating system.

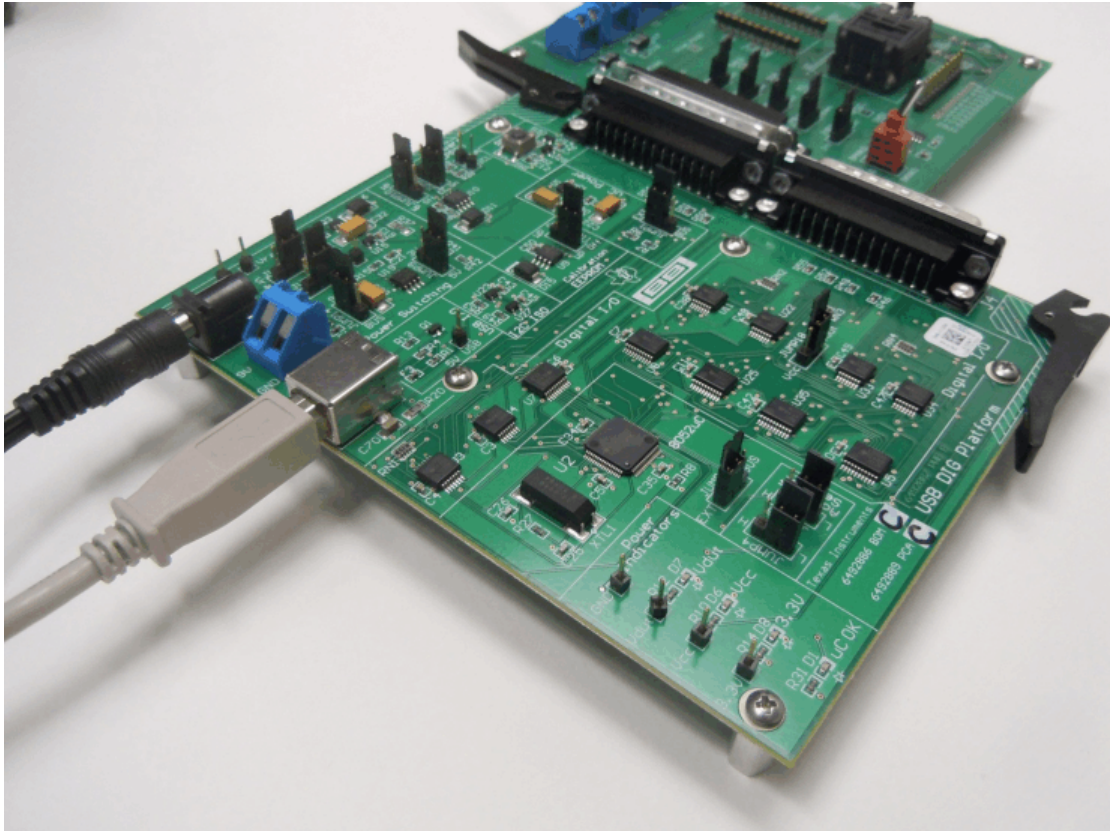

Figure 7. Connecting the USB Cable to the USB_DIG_Platform

In some cases, the Windows *Add Hardware Wizard* may pop up. If this prompt appears, allow the system device manager to install the human interface drivers by clicking **Yes** when requested to install drivers. Windows will confirm installation of the drivers with the message shown in [Figure 8](#).



Figure 8. Confirmation of USB_DIG_Platform Driver Installation

3.6 BUF16821EVM-USB Default Jumper Settings

Figure 9 shows the default jumper configuration for the BUF16821EVM-USB. In general, the jumper settings of the USB_DIG_Platform will not need to be changed. You may want to change some of the jumpers on the BUF16821EVM-USB board to match your specific configuration. For example, you may wish to set a specific I²C address.

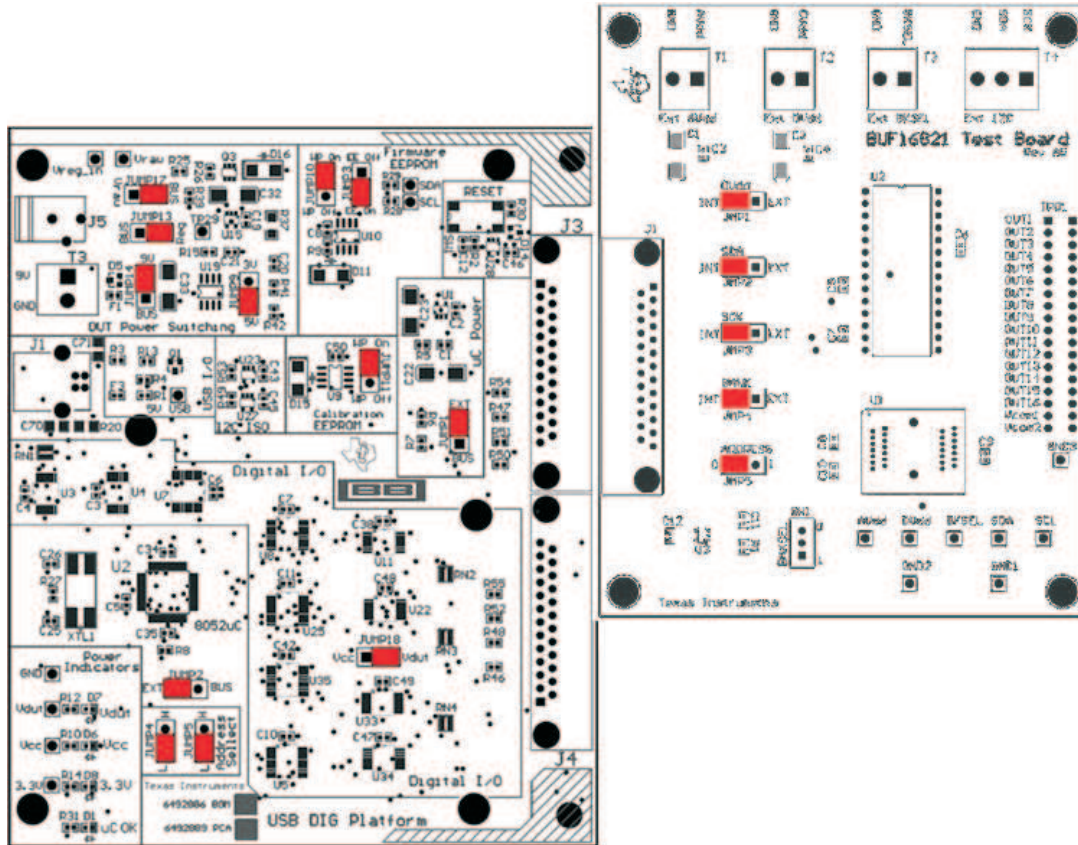

Figure 9. BUF16821EVM-USB Default Jumper Settings

Jumpers 1 through 4 on the BUF16821EVM-USB are all typically set to the same position. When set to the *INT* position, the signals from the digital supply, bank select, and the digital communication lines are generated and controlled from the USB_DIG_Platform or by the onboard bank select switch. When these jumpers are set to the *EXT* position, the previously-described signals connect to the terminal strips T2, T3, and T4. Jumper 5 controls the I²C address pin for the BUF16821. This jumper can set the address for A0 to either high or low.

Table 4 summarizes the function of the BUF16821EVM-USB test board jumpers. For most applications, Jumpers 1 through 5 are all set to the default positions.

Table 4. BUF16821EVM-USB Test Board Jumper Functions

Jumper	Default	Purpose
JMP1		This jumper selects whether the V_{SD} pin on the BUF16821 is connected to the V_{DUT} signal generated from the USB_DIG_Platform or whether the digital supply pin is connected to terminal T2, allowing for an external supply to power the digital circuitry. The default INT position connects the V_{SD} pin to the V_{DUT} control signal.
JMP2		This jumper selects whether the SDA pin on the BUF16821 is connected to the I2C_SDA_ISO signal generated from the USB_DIG_Platform or whether the SDA pin is connected to terminal T4, allowing for an external source to control the I ² C data line. The default INT position connects the SDA pin to the I2C_SDA_ISO control signal.
JMP3		This jumper selects whether the SCL pin on the BUF16821 is connected to the I2C_SCK_ISO signal generated from the USB_DIG_Platform or whether the SCL pin is connected to terminal T4, allowing for an external source to control the I ² C clock line. The default INT position connects the SCL pin to the I2C_SCK_ISO control signal.
JMP4		This jumper selects whether the BKSEL pin on the BUF16821 is controlled by the manual switch located on the BUF16821EVM-USB or whether the BKSEL can be controlled by an external source connected to terminal T3. The default INT position allows the BKSEL pin to be controlled by the manual switch.
JMP5		This jumper selects the I ² C A0 address. Two separate I ² C addresses can be selected depending upon whether JMP1 is set to high or low.

Table 5 summarizes the function of the USB_DIG_Platform jumpers. For most applications, the default jumper position should be used. A separate document ([SBOU058](#)) gives details regarding the operation and design of the USB_DIG_Platform.

Table 5. USB_DIG_Platform Jumper Functions

Jumper	Default	Purpose
JUMP1	EXT	This jumper selects external power or bus power. External power is applied on J5 or T3 (9V dc). Bus power is 5V from the USB bus. External power is typically used because the USB Bus power is noisy.
JUMP2	EXT	Same as JUMP1.
JUMP3	EE ON	This jumper determines where the TUSB3210 will load the USB_DIG_Platform firmware upon power-up or reset. The <i>EE Off</i> position is used for development for development or firmware update.
JUMP4, JUMP5	L, L	This jumper sets the address for the USB board. The only reason to change from the default setting is if multiple boards are being used.
JUMP9	5V	This jumper selects the voltage of the device under test supply ($V_{DUT} = 5V$ or $3V$). This jumper is typically the only jumper that is changed for most applications.
JUMP10	WP ON	This write protects the firmware EEPROM.
JUMP11	WP ON	This write protects the calibration EEPROM.

Table 5. USB_DIG_Platform Jumper Functions (continued)

Jumper	Default	Purpose
JUMP13	REG	Uses the regulator output to generate the V_{DUT} supply. The USB bus can be used as the V_{DUT} supply.
JUMP14	9V	Uses the external power (9V as opposed to the bus).
JUMP17	BUS	While in the BUS position V_{DUT} operation is normal. While in the V_{RAW} position the V_{DUT} supply is connected to an external source. This configuration allows for any value of V_{DUT} between 3V and 5V. ⁽¹⁾
JUMP18	V_{DUT}	Connects the pull-up on GPIO to the V_{DUT} supply or the V_{CC} supply.

⁽¹⁾ **CAUTION:** Adjusting outside of this range will damage the EVM.

3.7 BUF16821EVM-USB Features

This section describes some of the hardware features present on the BUF16821EVM-USB test board.

3.7.1 BKSEL: OTP Bank Selection Switch

The BKSEL switch located on the BUF16821EVM-USB Test Board selects the memory bank to be used when operating the EVM. Bank 0 selects the gamma curve that is stored in Bank_0 of the BUF16821. Bank 1 selects the gamma curve that is stored in Bank_1 of the BUF16821. This switch also determines the OTP bank that is written to by the BUF16821EVM-USB software. Note that this switch is not effective if JMP4 is set to EXT.

3.7.2 JMP1: I²C SCK Control Setting

Jumper JMP1 selects where the BUF16821 digital supply pin is connected. If JMP1 is set in the INT position, the VSD pin is connected to the switchable VDUT signal generated from the USB DIG Platform. This voltage can be set to either 3.3V or 5V depending on how JUMP9 on the USB DIG Platform is set. While JMP1 is set to the INT position, the VSD Power button on the BUF16821 software is able to control whether the VDUT supply voltage is turned on or off.

When JMP1 is set in the EXT position, an external supply connected to terminal T2 can be used to provide the digital supply voltage for the BUF16821.

3.7.3 JMP2: V_{SD} Control Setting

Jumper JMP2 selects where the BUF16821 I2C SDA pin is connected. If JMP2 is set in the INT position, the I2C data signal is generated from the I2C_SDA_ISO signal from the USB DIG Platform.

When JMP2 is set in the EXT position, an external source connected to SDA pin of terminal T4 can be used to provide the I2C SDA signal for the BUF16821.

3.7.4 JMP3: BKSEL Control Setting

Jumper JMP3 selects where the BUF16821 I2C SCL pin is connected. If JMP3 is set in the INT position, the I2C clock signal is generated from the I2C_SCK_ISO signal from the USB DIG Platform.

When JMP3 is set in the EXT position, an external source connected to SCL pin of terminal T4 can be used to provide the I2C SCK signal for the BUF16821.

3.7.5 JMP4: I²C SDA Control Setting

Jumper JMP4 determines how the OTP memory bank selection is controlled. There are two settings JMP4 can be set to. Position INT specifies that control of the BKSEL pin is handled on the BUF16821 Test Board by the BKSEL switch. Position EXT for JMP4 allows for an external control signal connected to terminal T3 to determine the selection of which OTP bank to be used.

3.7.6 JMP5: I²C Address Hardware Setting

Jumper JMP5 is used to set the hardware setting for the A0 I2C address pin on the BUF16821. Using JMP5, the A0 address can be set to either logic “1” or logic “0” to allow for two unique I2C addresses. See the section 5.2.1 on how to configure the BUF16821EVM software to match the JMP1 hardware setting.

3.7.7 BUF16821 Device Placement

The BUF16821EVM-USB allows the user two separate locations on the board where the BUF16821 test device can be installed.

The U2 location allows for a BUF16821 device that is soldered down on a DIP adaptor board to be installed on the BUF16821EVM. The output capability of the BUF16821 that is soldered on this adaptor board can be fully evaluated. The power pad of this soldered BUF16821 is connected correctly allowing the device to dissipate the necessary power while being evaluated.

The U1 location on the BUF16821EVM is a 28-pin test socket that allows the user to evaluate and program many devices very quickly. One drawback to this socket is that there is no connection to the PowerPAD™ of the BUF16821. Because of this drawback, while mounted in this socket, the BUF16821 cannot be operated at its full output capability as a result of thermal dissipation limitations.

CAUTION

Only one location should be populated at a time. The use of both locations simultaneously will damage one or both of the devices being tested.

3.7.8 Terminal Strip TPG1

Terminal strip TPG1 provides the individual output signals on a single row of headers as well as a row of vias. This footprint provides the user with multiple options regarding how to interface the output signals of the BUF16821 with the available display panel. Users can develop a custom cable to connect the headers to their respective panels directly, or to solder directly to the individual vias.

4 BUF16821EVM-USB Software

4.1 Hardware Requirements

The BUF16821EVM-USB software has been tested on Microsoft® Windows® XP, Vista, and Windows 7 operating systems (OS) with United States and European regional settings.

4.2 Software Installation

The BUF16821EVM-USB software is included on the CD that is shipped with the EVM kit. It is also available through the [BUF16821EVM-USB product folder](#) on the TI website. To install the software to a computer, insert the disc into an available CD-ROM drive. Navigate to the drive contents and open the BUF16821EVM-USB software folder. Locate the compressed file (*BUF16821EVM-USB.zip*) and open it using WinZIP® or a similar file compression program; extract the BUF16821EVM-USB files into a specific BUF16821EVM-USB folder (for example, *C:\BUF16821EVM-USB*) on your hard drive.

Once the files are extracted, navigate to the BUF16821EVM-USB folder you created on the hard drive. Locate the *setup.exe* file and execute it to start the installation. The BUF16821 software installer file then begins the installation process as shown in [Figure 10](#).

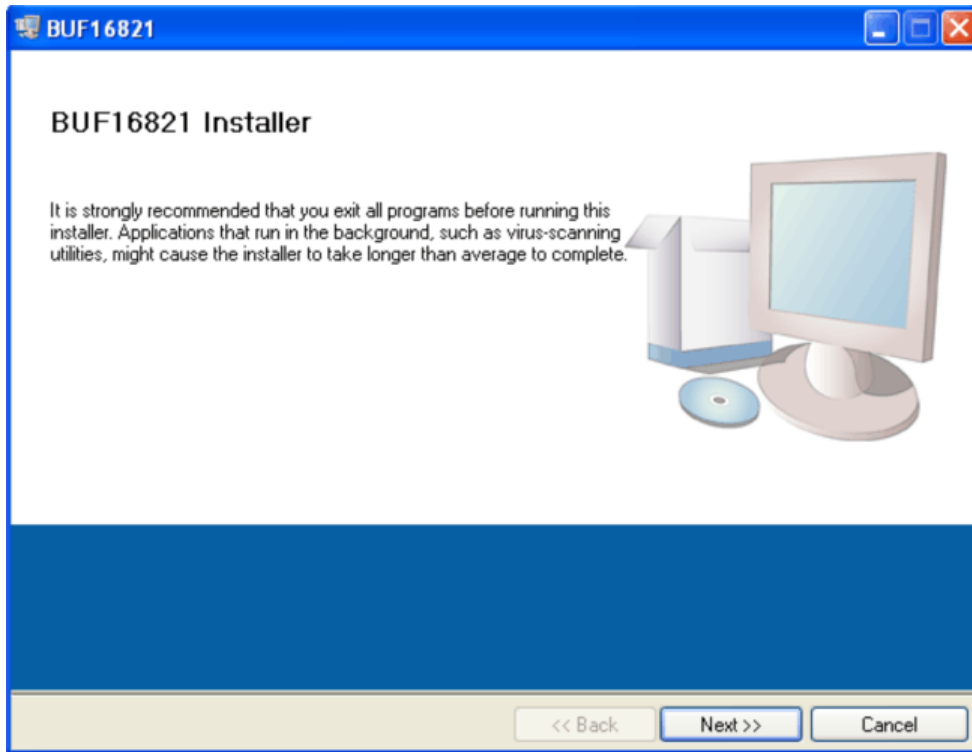

Figure 10. BUF16821EVM-USB Software Installation

After the installation process initializes, the user is given the choice of selecting the directory in which to install the program; the default location is *C:\Program Files\BUF16821* and *C:\Program Files\National Instruments*. Following this option, two license agreements are presented that must be accepted, as shown in [Figure 11](#). After accepting the Texas Instruments and National Instruments license agreements, the progress bar opens and shows the installation of the software, as [Figure 12](#) illustrates. Once the installation process is completed, click **Finish**.

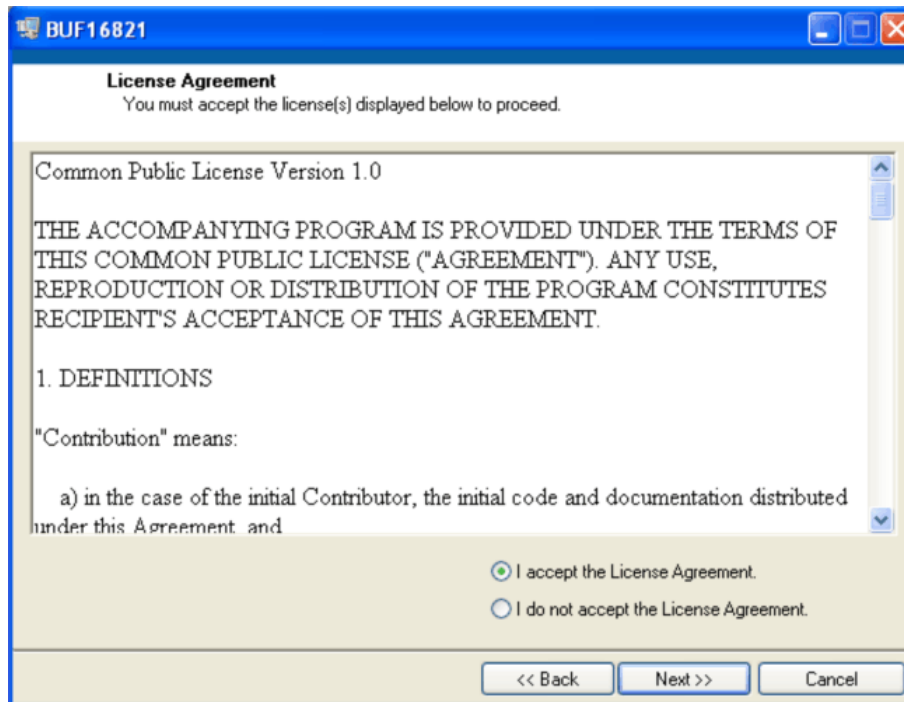

Figure 11. BUF16821EVM-USB License Agreements

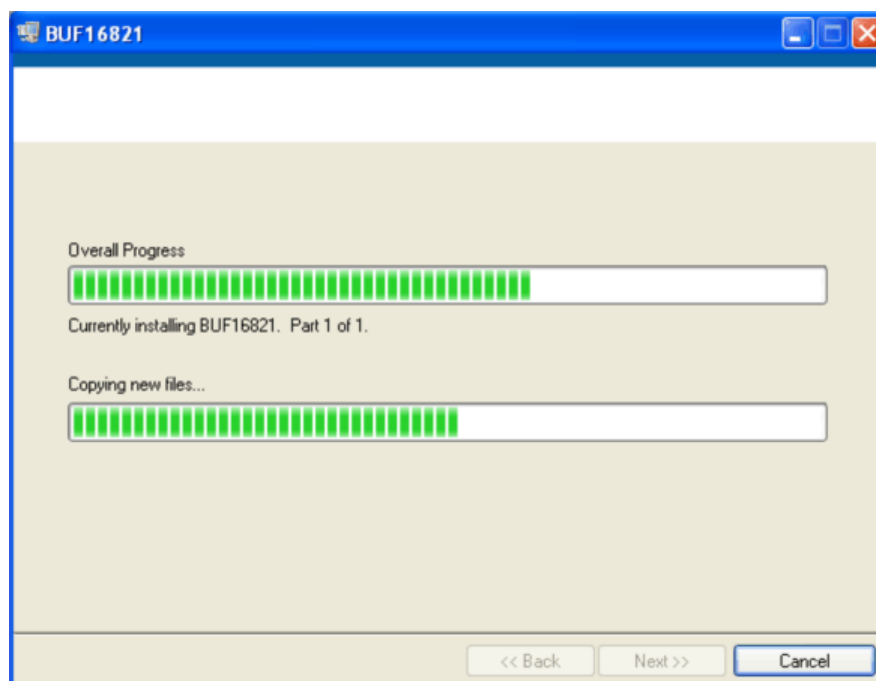

Figure 12. BUF16821EVM-USB Software Installation Progress

4.3 Software Description and Set-Up

The BUF16821EVM-USB software allows the user to read and write to all registers in the BUF16821 gamma correction buffer. Furthermore, it allows programming of the OTP register on the BUF16821. The software also permits the user to select either I²C address. Press the **About** button, as shown in Figure 13, to verify that you have the latest version of the software.

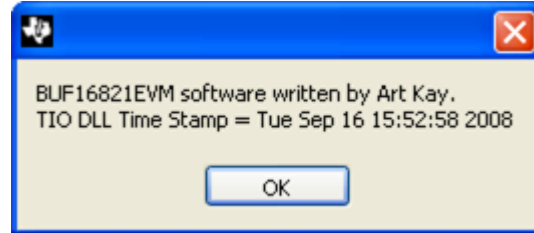

Figure 13. BUF16821EVM-USB Software *About* Button

5 BUF16821EVM-USB Software Overview

This section discusses how to use the BUF16821EVM-USB software.

5.1 Starting the BUF16821EVM-USB Software

The BUF16821 software can be operated through the Windows *Start* menu. From *Start*, select *All Programs*; then select the *BUF16821EVM-USB* program.

Figure 14 shows an error that pops up if the computer cannot communicate with the EVM. If you receive this error, first check to see that the USB cable is properly connected on both ends. This error can also occur if you connect the USB cable before the USB_DIG_Platform power source. Another possible source for this error is a problem with your PC USB Human Interface Device driver. Make sure that the device is recognized when the USB cable is plugged in; recognition is indicated by a Windows-generated confirmation sound.

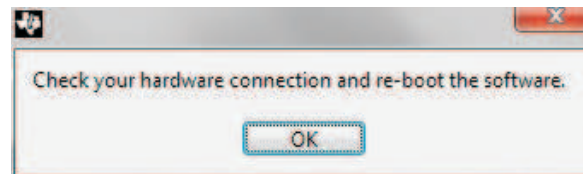

Figure 14. BUF16821EVM-USB Software: Communication Error with the USB_DIG_Platform

5.2 Using the BUF16821 Software

5.2.1 I²C Address Selection

As mentioned previously in the *BUF16821EVM-USB Features* section (see [Section 3.7](#)), jumper JMP5 is used to set the I²C address pin of the BUF16821. [Figure 15](#) shows how both the hardware and software must be set to allow for communication between the BUF16821EVM-USB and the software. Without jumper JMP5 and the software address button configured correctly, the software will not be able to communicate with the BUF16821 device.

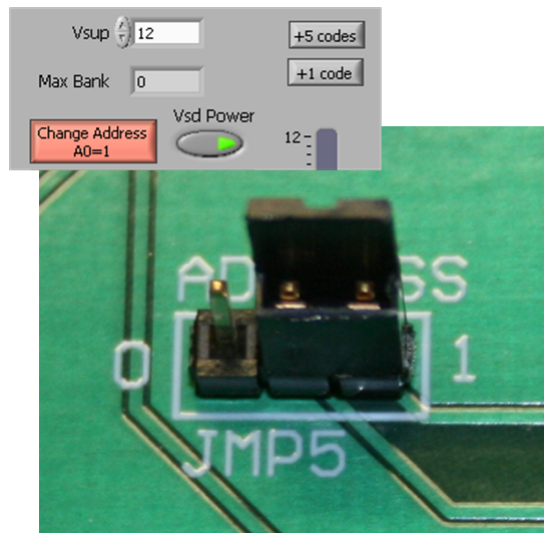

Figure 15. JMP5 Setting For Logic '1'

When JMP5 and the software are set as [Figure 16](#) shows, the second I²C address can be configured.

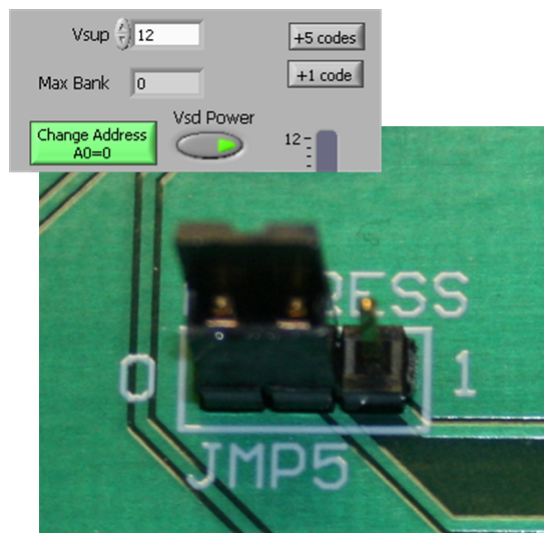

Figure 16. JMP5 Setting for Logic '0'

5.2.2 Measuring the Power Supply

You must measure the power supply (V_s) with respect to the GND on the BUF16821EVM-USB test board and enter it in the V_{SUP} field located in the top section of the software interface, as shown in [Figure 17](#).

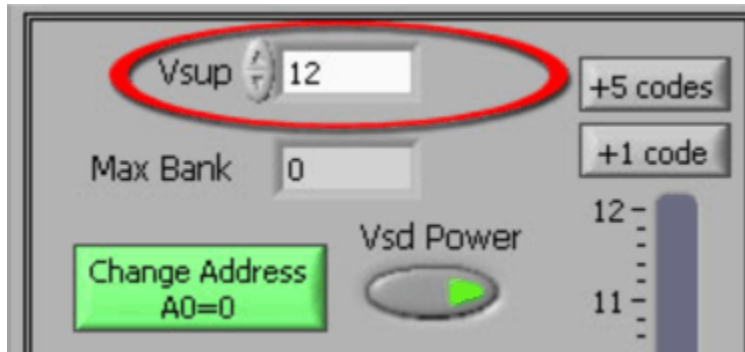

Figure 17. Measuring and Entering Power-Supply Voltage

The voltages calculated for each channel are based on the value entered as V_{SUP} , as shown in [Equation 1](#). Note that Code is the value found in the channel registry converted to decimal format.

$$V_{CHANNEL} = \frac{V_{SUP} \times Code}{1024} \quad (1)$$

5.2.3 Read DAC Button

By pressing the **Read DAC** button in the BUF16821EVM-USB software, all of the BUF16821 DAC/ V_{COM} registers are read to obtain the respective current register contents. Once the read procedure is complete, all of the corresponding text boxes are updated to show the current values present in the DAC/ V_{COM} registers.

5.2.4 Write DAC Button

The method used to write the values in the DAC/ V_{COM} registers is based on whether or not the Auto Write feature is enabled. The BUF16821 has two methods of writing information into the DAC/ V_{COM} registers. The first method allows for the output voltage to change immediately after the writing to the DAC register. In the BUF16821EVM-USB software, this mode is configured by enabling the Auto Write feature found in the *Buffer* dropdown menu. In this mode, as an individual channel is written to, the output voltage changes as soon as the user moves to a different text box in the software. The second method of writing to the DAC/ V_{COM} registers allows for the user to write multiple channels and then have all of the output voltages change at the same time, rather than each channel voltage changing as soon as it is written to.

Disabling the Auto Write feature in the software allows the user to enter all of the values desired for all of the channels and then press the **Write DAC** button to change all of the output voltage of all of the channels at one time. When the Auto Write feature is enabled, no change occurs to the output voltages when the **Write DAC** button is pressed. No change occurs because after the text box for a given channel has been updated, as soon as another item in the software is clicked, the Auto Write feature automatically performs a write command to the updated channel that then updates the output voltage. When in the Auto Write enabled mode, the **Write DAC** button cannot be pressed with different data in the corresponding channel text boxes than the values already stored in the DAC/ V_{COM} register; thus, no change occurs.

[Figure 18](#) shows the location in the Buffer Menu showing the Auto Write feature enabled. Clicking on the Auto Write feature again enables/disables the feature, depending on its current state.

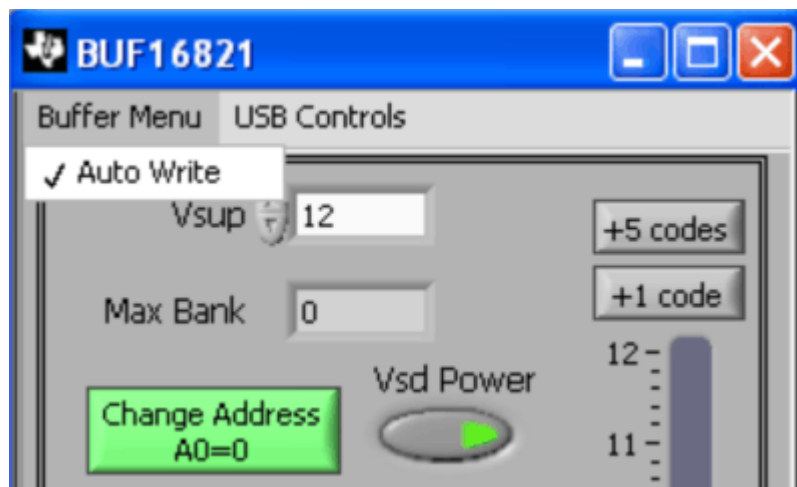

Figure 18. Auto Write Feature Enabled

5.2.5 Reset Button

Pressing the **Reset** button in the BUF16821EVM-USB software performs two functions. The first function is to call a General-Call Reset for the BUF16821. The status of the DAC/ V_{COM} registers after this General-Call Reset has been called depends upon whether the OTP has been programmed or not. If the OTP has been programmed, the channel registers are loaded with the most recent values programmed into the OTP memory. If the OTP memory has not been programmed, the channel registers default to *1000000000*, or mid-supply. The second function performed after the reset button is pressed is that a Read DAC call is made to update the corresponding channel text boxes to the current value for each channel.

5.2.6 Save to File Button

The register configurations of the BUF16821 DACs are displayed in both analog voltage and in hexadecimal formats. The DAC codes (that is, gamma voltages) can be saved into a text file by using the **Save to File** button.

Pressing the **Save to File** button opens a file-save dialog box similar to that shown in [Figure 19](#). Pressing the folder icon creates a new folder on your PC. It is a good idea to create a directory exclusively for BUF16821 DAC code (that is, gamma voltage) files. Enter a unique file name in the *File name* field to store your BUF16821 register information. Press the **OK** button to save the file.

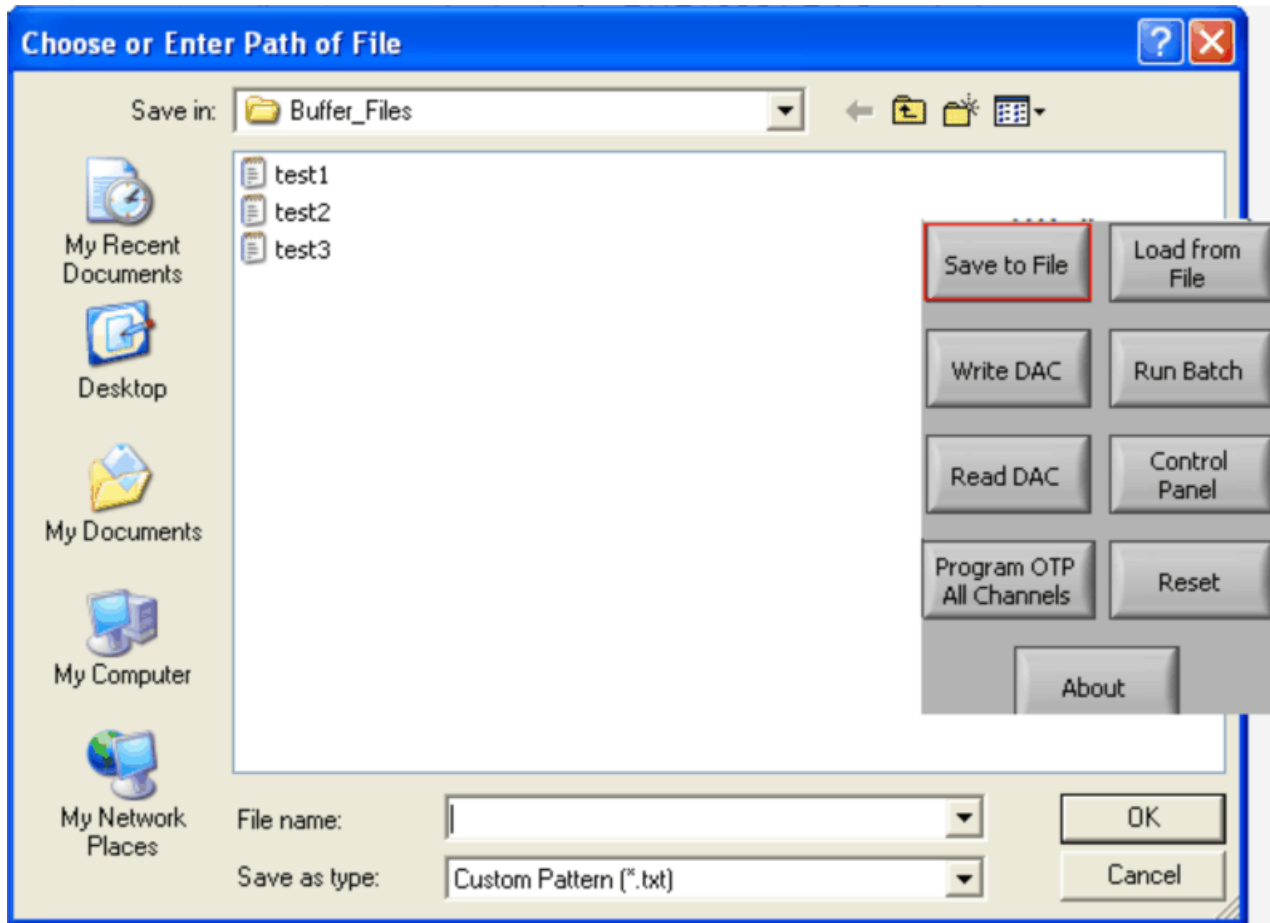

Figure 19. Save to File Dialog Box Button and Window

Saved BUF16821 DAC codes (gamma voltages) exist in a text file that can be opened in a text editor, as [Figure 20](#) illustrates.

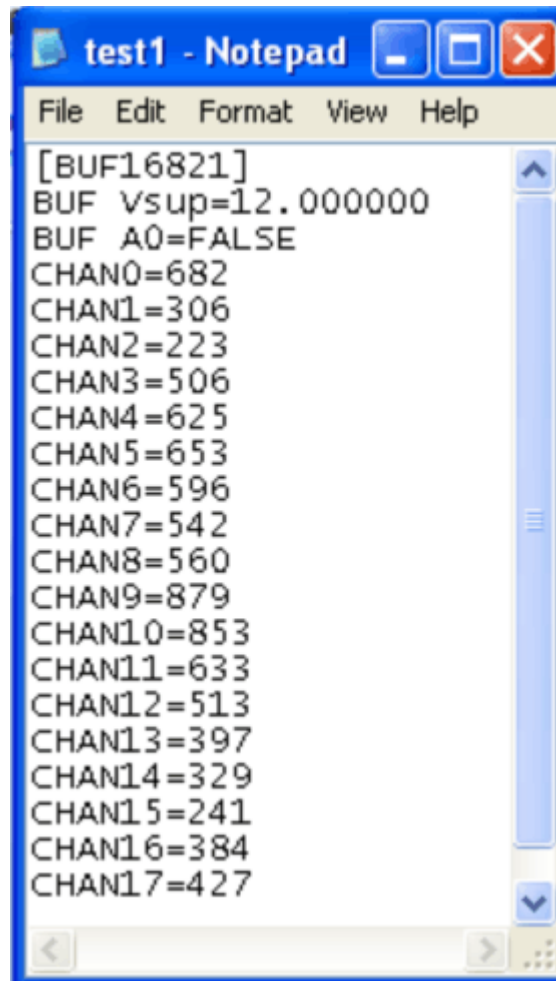

Figure 20. File Format of Saved Data

5.2.7 Load From File Button

The BUF16821EVM-USB software is also able to load data saved from previous evaluations. A saved register configuration can be loaded into the BUF16821 using the **Load From File** button, as shown in Figure 21. The program remembers where you saved the last register configuration. Simply select the desired configuration and press *Open*.

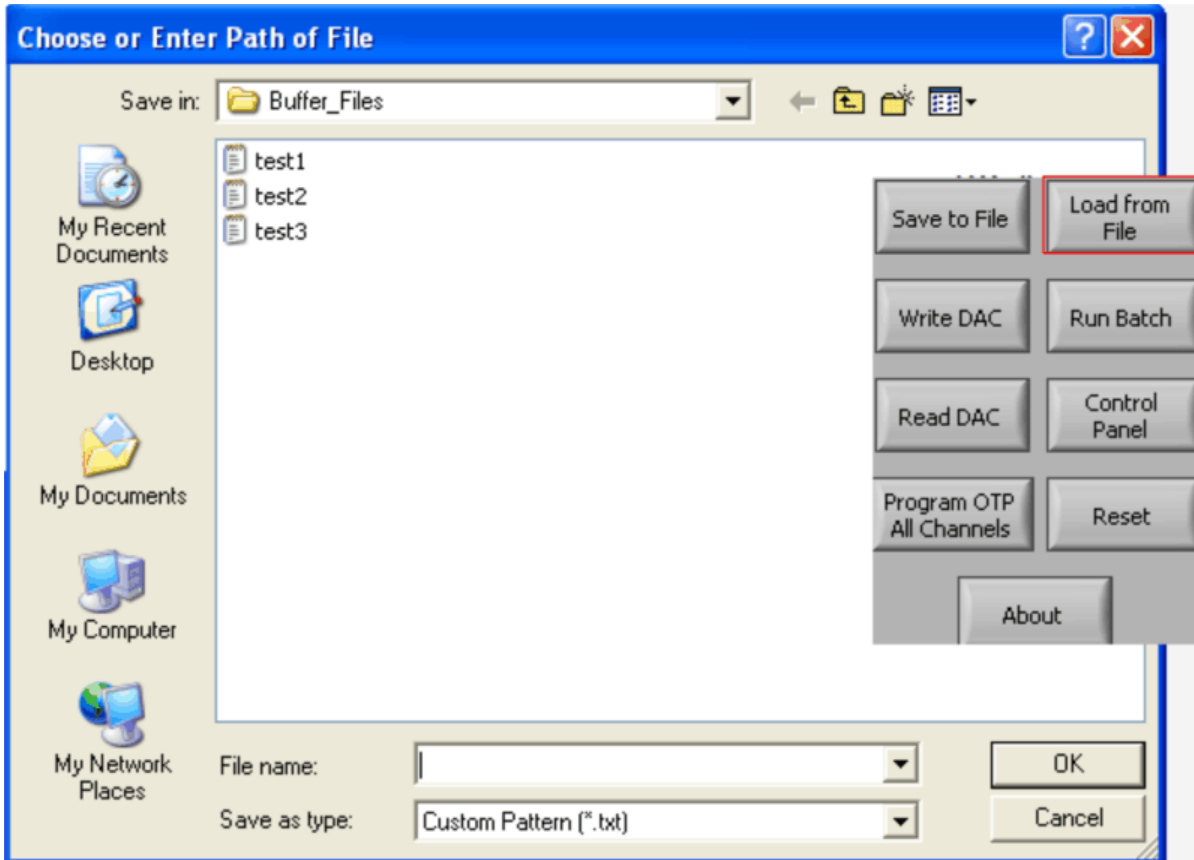

Figure 21. Load From File Button and Window

5.2.8 Changing the DAC/V_{COM} Analog Voltage

The voltage of any of the DAC or V_{COM} channels can be adjusted in several ways. First, you can change the voltage by entering the desired voltage directly in the voltage text box. In order to be able to manually type the voltage into the text box, you must first click on the cell to be edited. Click a second time and the cell turns from blue to black, and allows the user to type the updated voltage in the cell. The hexadecimal DAC codes can be entered in the *Code* column in the same manner.

Another method of changing the voltage of a DAC or V_{COM} channel is through the use of the slider on the main software window. There is only a single slider that is used for all channels. In order to use the slider to adjust the voltage of a particular channel, that channel must first be selected. To select a channel, click on either the channel number, voltage, or code of a particular channel. The entire channel row highlights in blue to show the user that the channel is selected. Adjusting the slider bar then only updates the highlighted channel.

The final method to change DAC/V_{COM} voltages is through the **±1 Code** and **±5 Code** buttons on the main software window. These buttons allow for fine and coarse adjustments, respectively, to the highlighted channel, giving the user the ability to quickly step the channel output up or down as needed without having to manually enter the changes in the *Code* column.

5.2.9 Run Batch Button

The **Run Batch** button (as highlighted in [Figure 22](#)) enables the user to configure the BUF16821 to cycle through different register configurations in a continuous loop. When connected to the end application, this feature can be used to cycle through different gamma settings to determine what the optimal settings must be for a given application.

When the **Run Batch** button is pressed, a new dialog box displays as [Figure 22](#) shows. The delay time is the amount of time allowed between loading new configurations into the BUF16821 DUT.

Use the **Single Step Up** and **Single Step Down** buttons to step through the selected files manually. The currently-selected file name is displayed in the lower left corner area of the dialog box. Double-click on the file names to select them. Once a series of filenames have been selected, the check box turns dark. Double-click on a filename again to unselect it from the batch run.

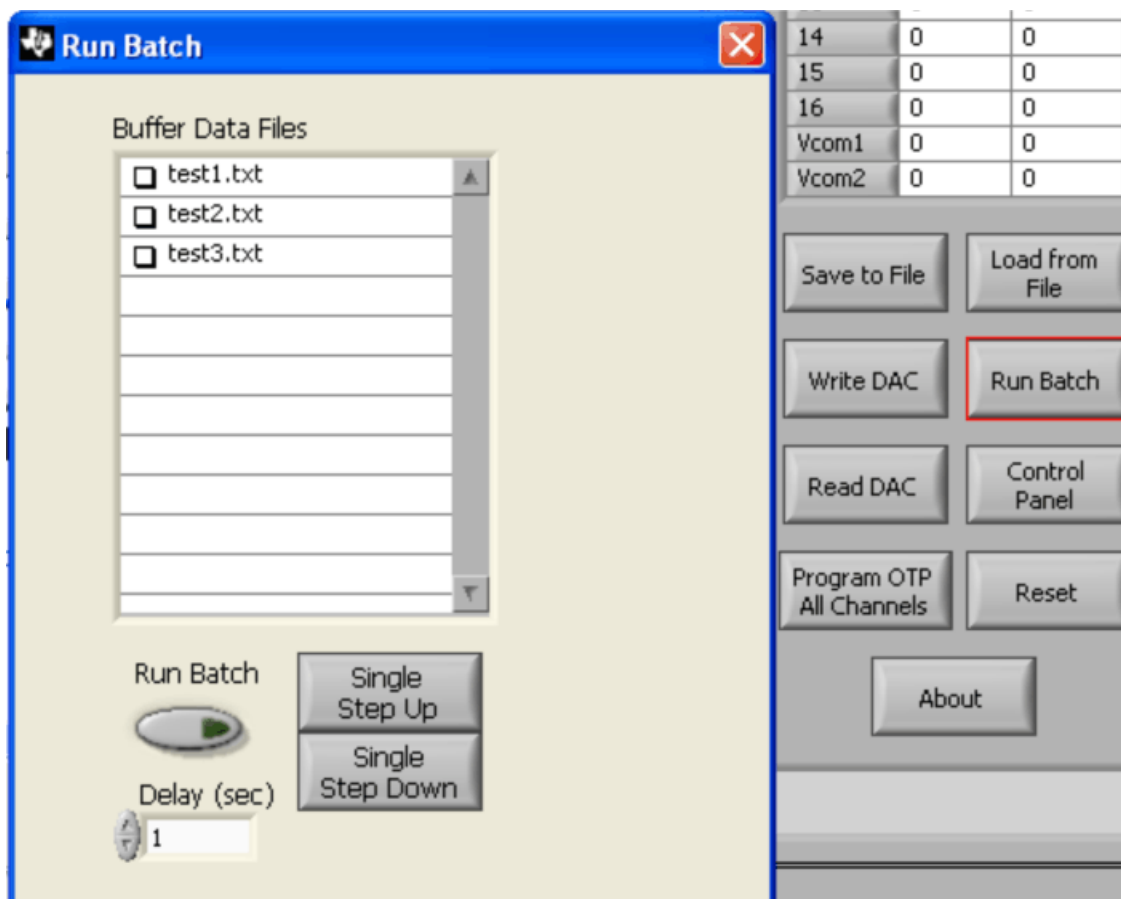

Figure 22. Run Batch Dialog Button and Window

5.2.10 Control Panel Button

Pressing the **Control Panel** button brings up a display panel that allows you to adjust each channel using a set of graphical sliders, as shown in [Figure 23](#). Simply drag the slider to adjust the desired channel output. The DAC code and corresponding output value of each channel change automatically. This function is similar to the slider present on the primary BUF16821EVM-USB software window that changes based on the channel that highlighted (as discussed in the [above section](#)).

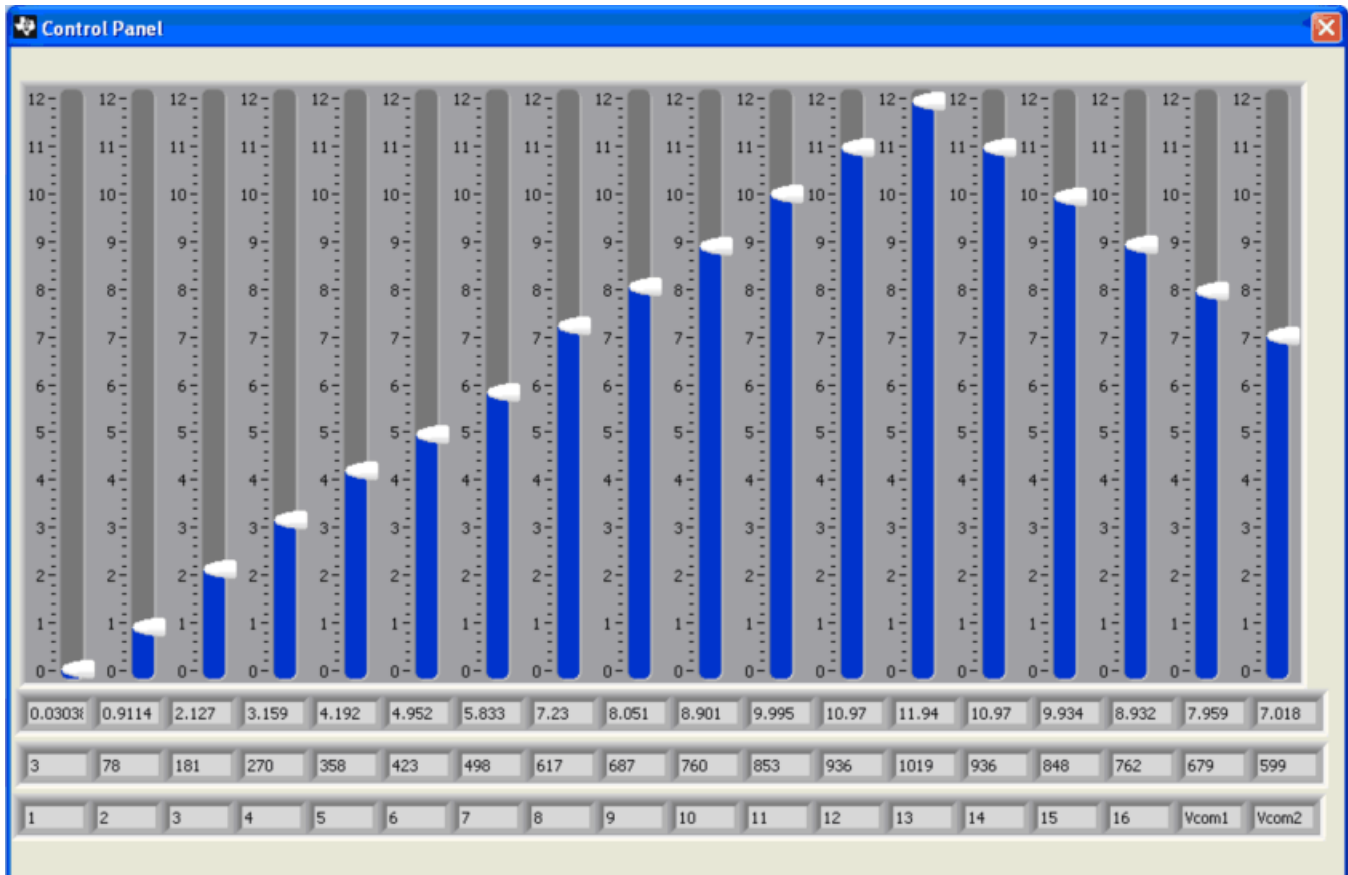

Figure 23. Control Panel Button and Window

5.2.11 Program OTP All Channels Button

Pressing the **Program OTP All Channels** button allows you to program the current gamma curve into the nonvolatile memory in the BUF16821. All channels (including the V_{COM}) are then programmed simultaneously. The values are stored in the memory bank that is selected via the BKSEL switch (see Section 3.7.2xx).

6 Hardware and Schematic

This section contains the complete bill of materials, schematic diagram, and PCB layouts for the BUF16821EVM-USB.

NOTE: Board layouts are not to scale. These are intended to show how the board is laid out; they are not intended to be used for manufacturing BUF16821EVM-USB PCBs.

6.1 Schematic

Figure 24 shows the schematic for the BUF16821EVM-USB.

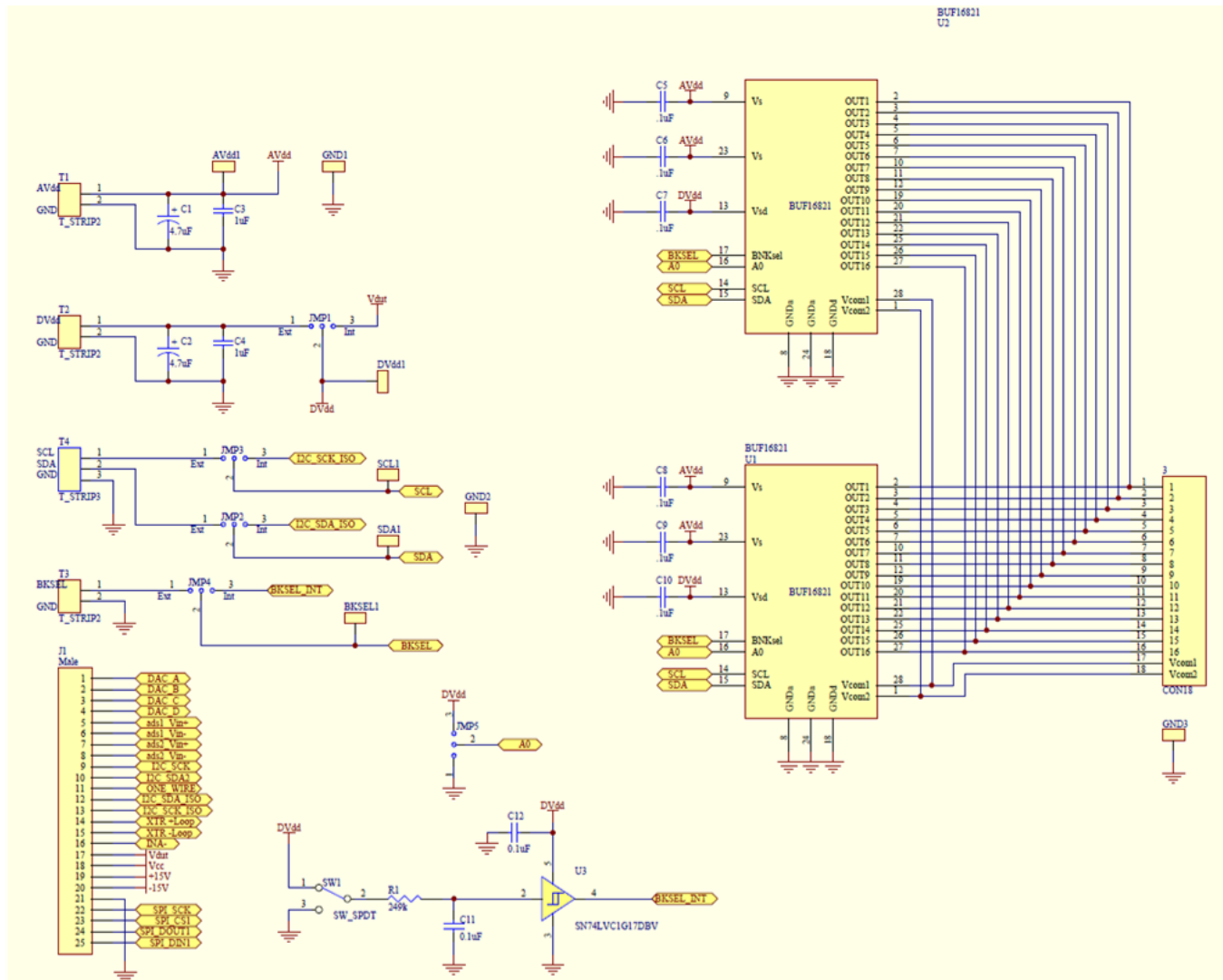

Figure 24. BUF16821EVM-USB Schematic

6.2 PCB Layouts

Figure 25 shows the PCB layout of the BUF16821EVM-USB.

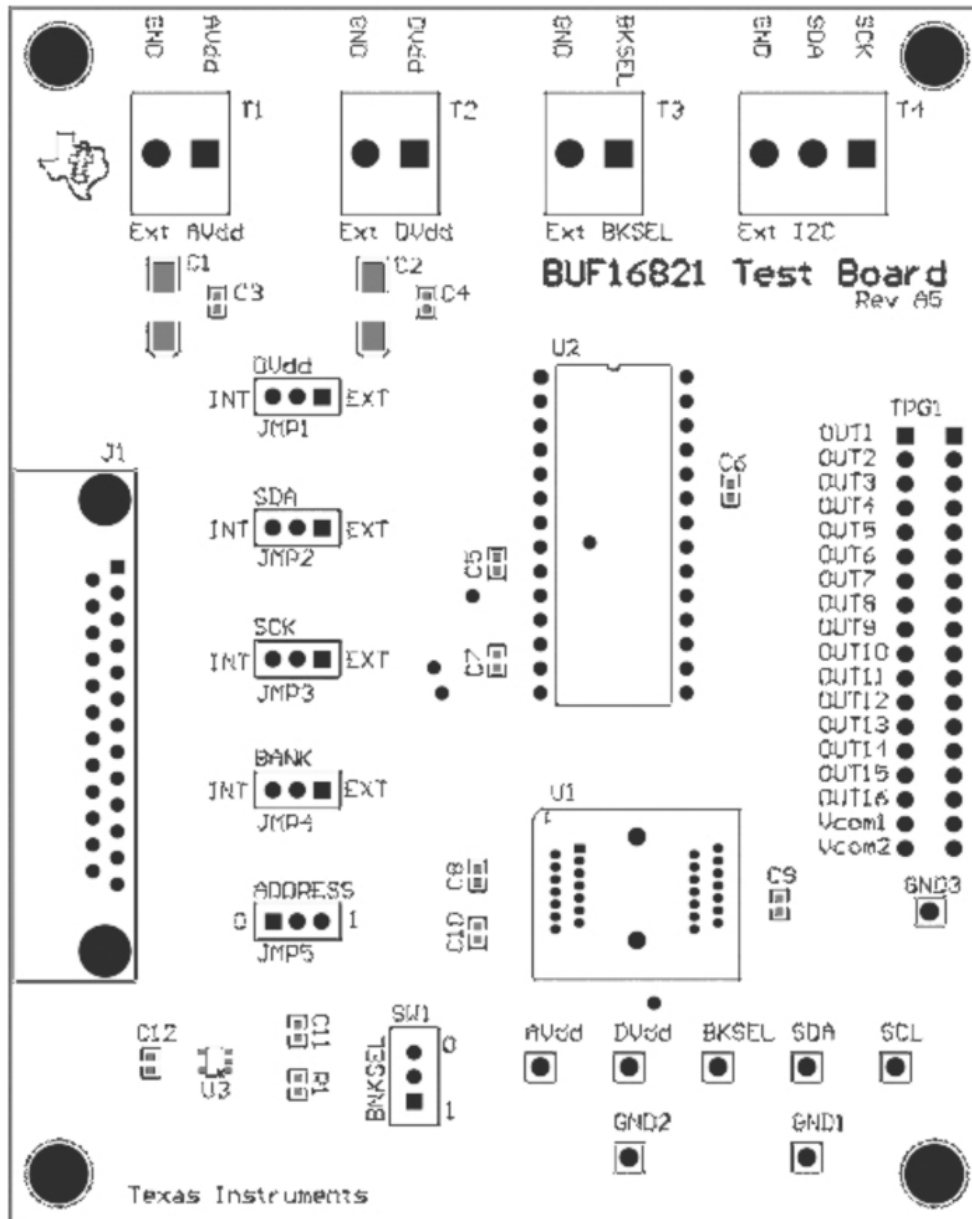

Figure 25. BUF16821EVM-USB PCB Top Layer (Component Side)

6.3 Bill of Materials

Table 6 lists the bill of materials for this EVM.

Table 6. Bill of Materials

Item No.	Qty	Value	Ref Des	Description	Vendor/Mfr	Part Number
1	1	249 kΩ	R1	Resistor, 249 kΩ 1/16W .5% 0603 SMD	Susumu Co Ltd	RR0816P-2493-D-39D
2	2	4.7 μF	C1, C2	Capacitor, Tantalum, 4.7 μF 35V 10% SMD	Vishay/Sprague	293D475X9035C2TE3
3	2	1 μF	C3, C4	Capacitor, Ceramic, 1 μF 25V Y5V 0603	Murata Electronics North America	GRM188F51E105ZA12D
4	8	0.1 μF	C5-C12	Capacitor, 0.10-μF 25-V Ceramic Y5V 0603	Kemet	C0603C104Z3VACTU
5	1		U1	Socket, TSSOP 28-Pin ZIF	ENPLAS	OTS-28(28)-0.65-01
6	2		U2	Connector, RCPT .100" 14-Pos Gold T/H	Samtec Inc	SS-114-G-2
7	1		U3	IC Buffer Schmitt Trigger SOT235	Texas Instruments	SN74LVC1G17DBVR
8	1	DSUB25M	J1	Connector, D-SUB Plug R/A 25-Pos 30Gold (with threaded inserts and board locks)	AMP/Tyco Electronics	5747842-4
9	1		SW1	Switch Toggle SPDT .4VA PC Mount	E-Switch	200AWMSP1T1A1M2RE
10	3		T1-T3	Terminal block 5MM 2-Pos	On-Shore Technology Inc	ED300/2
11	1		T4	Terminal block 5MM 3-Pos	On-Shore Technology Inc	ED300/3
12	1		T5	Connector, Header 18-Pos .100" SGL Gold	Samtec	TSW-118-07-G-S
13	8		Test Points, All	Connector, Header 1-Pos .100" SGL Gold	Samtec	TSW-101-07-G-S
14	4	Standoff	None	Standoffs, Hex , 4-40 Threaded, 0.500" length, 0.250" OD, Aluminum Iridite Finish	Keystone	2203
15	4	Screw	None	Screw Machine Phillips 4-40X1/4 SS	Building Fasteners	PMSSS 440 0025 PH
16	5		JMP1-JMP5	Connector, Header 3-Pos .100" SGL Gold	Samtec	TSW-103-07-G-S

Evaluation Board/Kit Important Notice

Texas Instruments (TI) provides the enclosed product(s) under the following conditions:

This evaluation board/kit is intended for use for **ENGINEERING DEVELOPMENT, DEMONSTRATION, OR EVALUATION PURPOSES ONLY** and is not considered by TI to be a finished end-product fit for general consumer use. Persons handling the product(s) must have electronics training and observe good engineering practice standards. As such, the goods being provided are not intended to be complete in terms of required design-, marketing-, and/or manufacturing-related protective considerations, including product safety and environmental measures typically found in end products that incorporate such semiconductor components or circuit boards. This evaluation board/kit does not fall within the scope of the European Union directives regarding electromagnetic compatibility, restricted substances (RoHS), recycling (WEEE), FCC, CE or UL, and therefore may not meet the technical requirements of these directives or other related directives.

Should this evaluation board/kit not meet the specifications indicated in the User's Guide, the board/kit may be returned within 30 days from the date of delivery for a full refund. **THE FOREGOING WARRANTY IS THE EXCLUSIVE WARRANTY MADE BY SELLER TO BUYER AND IS IN LIEU OF ALL OTHER WARRANTIES, EXPRESSED, IMPLIED, OR STATUTORY, INCLUDING ANY WARRANTY OF MERCHANTABILITY OR FITNESS FOR ANY PARTICULAR PURPOSE.**

The user assumes all responsibility and liability for proper and safe handling of the goods. Further, the user indemnifies TI from all claims arising from the handling or use of the goods. Due to the open construction of the product, it is the user's responsibility to take any and all appropriate precautions with regard to electrostatic discharge.

EXCEPT TO THE EXTENT OF THE INDEMNITY SET FORTH ABOVE, NEITHER PARTY SHALL BE LIABLE TO THE OTHER FOR ANY INDIRECT, SPECIAL, INCIDENTAL, OR CONSEQUENTIAL DAMAGES.

TI currently deals with a variety of customers for products, and therefore our arrangement with the user **is not exclusive.**

TI assumes **no liability for applications assistance, customer product design, software performance, or infringement of patents or services described herein.**

Please read the User's Guide and, specifically, the Warnings and Restrictions notice in the User's Guide prior to handling the product. This notice contains important safety information about temperatures and voltages. For additional information on TI's environmental and/or safety programs, please contact the TI application engineer or visit www.ti.com/esh.

No license is granted under any patent right or other intellectual property right of TI covering or relating to any machine, process, or combination in which such TI products or services might be or are used.

FCC Warning

This evaluation board/kit is intended for use for **ENGINEERING DEVELOPMENT, DEMONSTRATION, OR EVALUATION PURPOSES ONLY** and is not considered by TI to be a finished end-product fit for general consumer use. It generates, uses, and can radiate radio frequency energy and has not been tested for compliance with the limits of computing devices pursuant to part 15 of FCC rules, which are designed to provide reasonable protection against radio frequency interference. Operation of this equipment in other environments may cause interference with radio communications, in which case the user at his own expense will be required to take whatever measures may be required to correct this interference.

EVM Warnings and Restrictions

It is important to operate this EVM within the input voltage range of 9V (min) to 20V (max) and the output voltage range of 9V (min) to 20V (max).

Exceeding the specified input range may cause unexpected operation and/or irreversible damage to the EVM. If there are questions concerning the input range, please contact a TI field representative prior to connecting the input power.

Applying loads outside of the specified output range may result in unintended operation and/or possible permanent damage to the EVM. Please consult the EVM User's Guide prior to connecting any load to the EVM output. If there is uncertainty as to the load specification, please contact a TI field representative.

During normal operation, some circuit components may have case temperatures greater than +25°C. The EVM is designed to operate properly with certain components above +25°C as long as the input and output ranges are maintained. These components include but are not limited to linear regulators, switching transistors, pass transistors, and current sense resistors. These types of devices can be identified using the EVM schematic located in the EVM User's Guide. When placing measurement probes near these devices during operation, please be aware that these devices may be very warm to the touch.

Mailing Address: Texas Instruments, Post Office Box 655303, Dallas, Texas 75265
Copyright © 2011, Texas Instruments Incorporated

IMPORTANT NOTICE

Texas Instruments Incorporated and its subsidiaries (TI) reserve the right to make corrections, modifications, enhancements, improvements, and other changes to its products and services at any time and to discontinue any product or service without notice. Customers should obtain the latest relevant information before placing orders and should verify that such information is current and complete. All products are sold subject to TI's terms and conditions of sale supplied at the time of order acknowledgment.

TI warrants performance of its hardware products to the specifications applicable at the time of sale in accordance with TI's standard warranty. Testing and other quality control techniques are used to the extent TI deems necessary to support this warranty. Except where mandated by government requirements, testing of all parameters of each product is not necessarily performed.

TI assumes no liability for applications assistance or customer product design. Customers are responsible for their products and applications using TI components. To minimize the risks associated with customer products and applications, customers should provide adequate design and operating safeguards.

TI does not warrant or represent that any license, either express or implied, is granted under any TI patent right, copyright, mask work right, or other TI intellectual property right relating to any combination, machine, or process in which TI products or services are used. Information published by TI regarding third-party products or services does not constitute a license from TI to use such products or services or a warranty or endorsement thereof. Use of such information may require a license from a third party under the patents or other intellectual property of the third party, or a license from TI under the patents or other intellectual property of TI.

Reproduction of TI information in TI data books or data sheets is permissible only if reproduction is without alteration and is accompanied by all associated warranties, conditions, limitations, and notices. Reproduction of this information with alteration is an unfair and deceptive business practice. TI is not responsible or liable for such altered documentation. Information of third parties may be subject to additional restrictions.

Resale of TI products or services with statements different from or beyond the parameters stated by TI for that product or service voids all express and any implied warranties for the associated TI product or service and is an unfair and deceptive business practice. TI is not responsible or liable for any such statements.

TI products are not authorized for use in safety-critical applications (such as life support) where a failure of the TI product would reasonably be expected to cause severe personal injury or death, unless officers of the parties have executed an agreement specifically governing such use. Buyers represent that they have all necessary expertise in the safety and regulatory ramifications of their applications, and acknowledge and agree that they are solely responsible for all legal, regulatory and safety-related requirements concerning their products and any use of TI products in such safety-critical applications, notwithstanding any applications-related information or support that may be provided by TI. Further, Buyers must fully indemnify TI and its representatives against any damages arising out of the use of TI products in such safety-critical applications.

TI products are neither designed nor intended for use in military/aerospace applications or environments unless the TI products are specifically designated by TI as military-grade or "enhanced plastic." Only products designated by TI as military-grade meet military specifications. Buyers acknowledge and agree that any such use of TI products which TI has not designated as military-grade is solely at the Buyer's risk, and that they are solely responsible for compliance with all legal and regulatory requirements in connection with such use.

TI products are neither designed nor intended for use in automotive applications or environments unless the specific TI products are designated by TI as compliant with ISO/TS 16949 requirements. Buyers acknowledge and agree that, if they use any non-designated products in automotive applications, TI will not be responsible for any failure to meet such requirements.

Following are URLs where you can obtain information on other Texas Instruments products and application solutions:

Products

Audio	www.ti.com/audio
Amplifiers	amplifier.ti.com
Data Converters	dataconverter.ti.com
DLP® Products	www.dlp.com
DSP	dsp.ti.com
Clocks and Timers	www.ti.com/clocks
Interface	interface.ti.com
Logic	logic.ti.com
Power Mgmt	power.ti.com
Microcontrollers	microcontroller.ti.com
RFID	www.ti-rfid.com
RF/IF and ZigBee® Solutions	www.ti.com/lprf

Applications

Communications and Telecom	www.ti.com/communications
Computers and Peripherals	www.ti.com/computers
Consumer Electronics	www.ti.com/consumer-apps
Energy and Lighting	www.ti.com/energy
Industrial	www.ti.com/industrial
Medical	www.ti.com/medical
Security	www.ti.com/security
Space, Avionics and Defense	www.ti.com/space-avionics-defense
Transportation and Automotive	www.ti.com/automotive
Video and Imaging	www.ti.com/video
Wireless	www.ti.com/wireless-apps

TI E2E Community Home Page

e2e.ti.com

Mailing Address: Texas Instruments, Post Office Box 655303, Dallas, Texas 75265
Copyright © 2011, Texas Instruments Incorporated