



April 2015

MCT5210M, MCT5211M

6-Pin DIP Low Input Current Phototransistor Optocouplers

Features

- High $CTR_{CE(SAT)}$ Comparable to Darlington
- High Common Mode Transient Rejection: 5 kV/ μ s
- Data Rates Up to 150 kbits/s (NRZ)
- Safety and Regulatory Approvals:
 - UL1577, 4,170 VAC_{RMS} for 1 Minute
 - DIN-EN/IEC60747-5-5, 850 V Peak Working Insulation Voltage

Applications

- CMOS to CMOS/LSTTL Logic Isolation
- LSTTL to CMOS/LSTTL Logic Isolation
- RS-232 Line Receiver
- Telephone Ring Detector
- AC Line Voltage Sensing
- Switching Power Supply

Description

The MCT5210M and MCT5211M devices consist of a high-efficiency AlGaAs infrared emitting diode coupled with an NPN phototransistor in a six-pin dual-in-line package.

The devices are well suited for CMOS to LSTTL/TTL interfaces, offering 250% $CTR_{CE(SAT)}$ with 1 mA of LED input current. With an LED input current of 1.6 mA, data rates to 20K bits/s are possible.

Both can easily interface LSTTL to LSTTL/TTL, and with use of an external base-to-emitter resistor data rates of 100K bits/s can be achieved.

Schematic

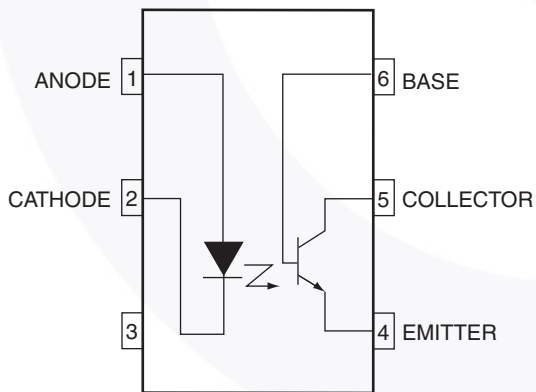

Figure 1. Schematic

Package Outlines

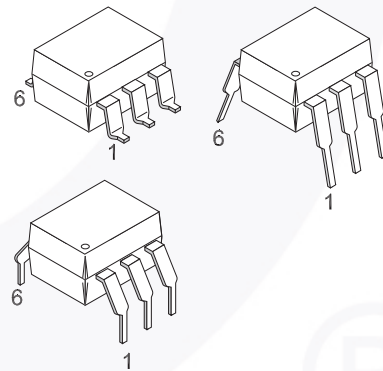

Figure 2. Package Outlines

MCT5210M, MCT5211M — 6-Pin DIP Low Input Current Phototransistor Optocouplers

Safety and Insulation Ratings

As per DIN EN/IEC 60747-5-5, this optocoupler is suitable for “safe electrical insulation” only within the safety limit data. Compliance with the safety ratings shall be ensured by means of protective circuits.

Parameter		Characteristics
Installation Classifications per DIN VDE 0110/1.89 Table 1, For Rated Mains Voltage	< 150 V _{RMS}	I–IV
	< 300 V _{RMS}	I–IV
Climatic Classification		55/100/21
Pollution Degree (DIN VDE 0110/1.89)		2
Comparative Tracking Index		175

Symbol	Parameter	Value	Unit
V _{PR}	Input-to-Output Test Voltage, Method A, V _{IORM} × 1.6 = V _{PR} , Type and Sample Test with t _m = 10 s, Partial Discharge < 5 pC	1360	V _{peak}
	Input-to-Output Test Voltage, Method B, V _{IORM} × 1.875 = V _{PR} , 100% Production Test with t _m = 1 s, Partial Discharge < 5 pC	1594	V _{peak}
V _{IORM}	Maximum Working Insulation Voltage	850	V _{peak}
V _{IOTM}	Highest Allowable Over-Voltage	6000	V _{peak}
	External Creepage	≥ 7	mm
	External Clearance	≥ 7	mm
	External Clearance (for Option TV, 0.4" Lead Spacing)	≥ 10	mm
DTI	Distance Through Insulation (Insulation Thickness)	≥ 0.5	mm
T _S	Case Temperature ⁽¹⁾	175	°C
I _{S,INPUT}	Input Current ⁽¹⁾	350	mA
P _{S,OUTPUT}	Output Power ⁽¹⁾	800	mW
R _{IO}	Insulation Resistance at T _S , V _{IO} = 500 V ⁽¹⁾	> 10 ⁹	Ω

Note:

1. Safety limit values – maximum values allowed in the event of a failure.

Absolute Maximum Ratings

Stresses exceeding the absolute maximum ratings may damage the device. The device may not function or be operable above the recommended operating conditions and stressing the parts to these levels is not recommended. In addition, extended exposure to stresses above the recommended operating conditions may affect device reliability. The absolute maximum ratings are stress ratings only.

Symbol	Parameters	Value	Unit
TOTAL DEVICE			
T _{STG}	Storage Temperature	-40 to +125	°C
T _{OPR}	Operating Temperature	-40 to +100	°C
T _J	Junction Temperature	-40 to +125	°C
T _{SOL}	Lead Solder Temperature	260 for 10 seconds	°C
P _D	Total Device Power Dissipation @ 25°C (LED plus detector)	225	mW
	Derate Linearly From 25°C	3.5	mW/°C
EMITTER			
I _F	Continuous Forward Current	50	mA
V _R	Reverse Input Voltage	6	V
I _{F(pk)}	Forward Current – Peak (1 μs pulse, 300 pps)	3.0	A
P _D	LED Power Dissipation @ 25°C	75	mW
	Derate Linearly From 25°C	1.0	mW/°C
DETECTOR			
I _C	Continuous Collector Current	150	mA
P _D	Detector Power Dissipation @ 25°C	150	mW
	Derate Linearly From 25°C	2.0	mW/°C

Electrical Characteristics

$T_A = 25^\circ\text{C}$ unless otherwise specified.

Individual Component Characteristics

Symbol	Parameters	Test Conditions	Min.	Typ.	Max.	Unit
EMITTER						
V_F	Input Forward Voltage	$I_F = 5\text{ mA}$		1.25	1.50	V
$\frac{\Delta V_F}{\Delta T_A}$	Forward Voltage Temperature Coefficient	$I_F = 2\text{ mA}$		-1.75		mV/°C
V_R	Reverse Voltage	$I_R = 10\text{ }\mu\text{A}$	6			V
C_J	Junction Capacitance	$V_F = 0\text{ V}$, $f = 1.0\text{ MHz}$		18		pF
DETECTOR						
BV_{CEO}	Breakdown Voltage, Collector-to-Emitter	$I_C = 1.0\text{ mA}$, $I_F = 0$	30	100		V
BV_{CBO}	Breakdown Voltage, Collector-to-Base	$I_C = 10\text{ }\mu\text{A}$, $I_F = 0$	30	120		V
BV_{EBO}	Breakdown Voltage, Emitter-to-Base	$I_E = 10\text{ }\mu\text{A}$, $I_F = 0$	5	10		V
I_{CER}	Dark Current, Collector-to-Emitter	$V_{CE} = 10\text{ V}$, $I_F = 0$, $R_{BE} = 1\text{ M}\Omega$		1	100	nA
C_{CE}	Capacitance, Collector-to-Emitter	$V_{CE} = 0$, $f = 1\text{ MHz}$		10		pF
C_{CB}	Capacitance, Collector-to-Base	$V_{CB} = 0$, $f = 1\text{ MHz}$		80		pF
C_{EB}	Capacitance, Emitter-to-Base	$V_{EB} = 0$, $f = 1\text{ MHz}$		15		pF

Electrical Characteristics (Continued)T_A = 25°C unless otherwise specified.**Transfer Characteristics**

Symbol	Characteristics	Test Conditions	Device	Min.	Typ.	Max.	Unit
DC CHARACTERISTICS							
CTR _{CE(SAT)}	Saturated Current Transfer Ratio Collector-to-Emitter ⁽²⁾	I _F = 3.0 mA, V _{CE} = 0.4 V	MCT5210M	60			%
		I _F = 1.6 mA, V _{CE} = 0.4 V	MCT5211M	100			%
		I _F = 1.0 mA, V _{CE} = 0.4 V		75			%
CTR _(CE)	Current Transfer Ratio Collector-to-Emitter ⁽²⁾	I _F = 3.0 mA, V _{CE} = 5.0 V	MCT5210M	70			%
		I _F = 1.6 mA, V _{CE} = 5.0 V	MCT5211M	150			%
		I _F = 1.0 mA, V _{CE} = 5.0 V		110			%
CTR _(CB)	Current Transfer Ratio Collector-to-Base ⁽³⁾	I _F = 3.0 mA, V _{CE} = 4.3 V	MCT5210M	0.2			%
		I _F = 1.6 mA, V _{CE} = 4.3 V	MCT5211M	0.3			%
		I _F = 1.0 mA, V _{CE} = 4.3 V		0.25			%
V _{CE(SAT)}	Saturation Voltage	I _F = 3.0 mA, I _{CE} = 1.8 mA	MCT5210M			0.4	V
		I _F = 1.6 mA, I _{CE} = 1.6 mA	MCT5211M			0.4	V
AC CHARACTERISTICS							
T _{PHL}	Propagation Delay HIGH-to-LOW ⁽⁴⁾	R _L = 330 Ω, R _{BE} = ∞	I _F = 3.0 mA, V _{CC} = 5.0 V	MCT5210M	10		μs
		R _L = 3.3 kΩ, R _{BE} = 39 kΩ			7		μs
		R _L = 750 Ω, R _{BE} = ∞	I _F = 1.6 mA, V _{CC} = 5.0 V	MCT5211M	14		μs
		R _L = 4.7 kΩ, R _{BE} = 91 kΩ			15		μs
		R _L = 1.5 kΩ, R _{BE} = ∞	I _F = 1.0 mA, V _{CC} = 5.0 V	MCT5211M	17		μs
		R _L = 10 kΩ, R _{BE} = 160 kΩ			24		μs
T _{PLH}	Propagation Delay LOW-to-HIGH ⁽⁵⁾	R _L = 330 Ω, R _{BE} = ∞	I _F = 3.0 mA, V _{CC} = 5.0 V	MCT5210M	0.4		μs
		R _L = 3.3 kΩ, R _{BE} = 39 kΩ			8		μs
		R _L = 750 Ω, R _{BE} = ∞	I _F = 1.6 mA, V _{CC} = 5.0 V	MCT5211M	2.5		μs
		R _L = 4.7 kΩ, R _{BE} = 91 kΩ			11		μs
		R _L = 1.5 kΩ, R _{BE} = ∞	I _F = 1.0 mA, V _{CC} = 5.0 V	MCT5211M	7		μs
		R _L = 10 kΩ, R _{BE} = 160 kΩ			16		μs

Notes:

- DC Current Transfer Ratio (CTR_{CE}) is defined as the transistor collector current (I_{CE}) divided by the input LED current (I_F) x 100%, at a specified voltage between the collector and emitter (V_{CE}).
- The collector base Current Transfer Ratio (CTR_{CB}) is defined as the transistor collector base photocurrent (I_{CB}) divided by the input LED current (I_F) time 100%.
- Referring to Figure 16 the T_{PHL} propagation delay is measured from the 50% point of the rising edge of the data input pulse to the 1.3 V point on the falling edge of the output pulse.
- Referring to Figure 16 the T_{PLH} propagation delay is measured from the 50% point of the falling edge of data input pulse to the 1.3 V point on the rising edge of the output pulse.

Electrical Characteristics (Continued)

$T_A = 25^\circ\text{C}$ unless otherwise specified.

Isolation Characteristics

Symbol	Characteristic	Test Conditions	Min.	Typ.	Max.	Unit
V_{ISO}	Input-Output Isolation Voltage ⁽⁶⁾	$t = 1$ Minute	4170			$V_{\text{AC}_{\text{RMS}}}$
R_{ISO}	Isolation Resistance ⁽⁶⁾	$V_{\text{I-O}} = \pm 500$ VDC, $T_A = 25^\circ\text{C}$	10^{11}			Ω
C_{ISO}	Isolation Capacitance ⁽⁷⁾	$V_{\text{I-O}} = 0$ V, $f = 1$ MHz		0.4	0.6	pF
CM_{H}	Common Mode Transient Rejection – Output HIGH	$V_{\text{CM}} = 50$ V _{P-P} , $R_{\text{L}} = 750$ Ω , $I_{\text{F}} = 0$		5000		V/ μs
CM_{L}	Common Mode Transient Rejection – Output LOW	$V_{\text{CM}} = 50$ V _{P-P} , $R_{\text{L}} = 750$ Ω , $I_{\text{F}} = 1.6$ mA		5000		V/ μs

Notes:

- Device considered a two terminal device: pins 1, 2, and 3 shorted together and pins 5, 6 and 7 are shorted together.
- C_{ISO} is the capacitance between the input (pins 1, 2, 3 connected) and the output (pin 4, 5, 6 connected).

Typical Performance Curves

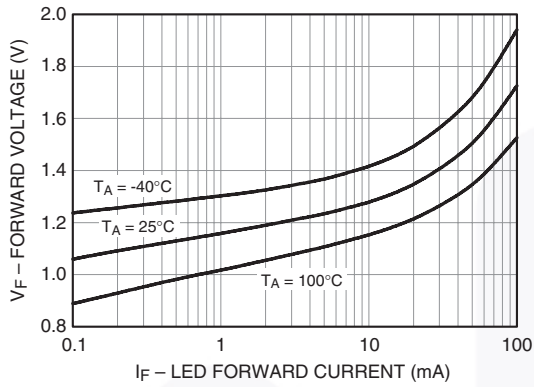

Figure 3. LED Forward Voltage vs. Forward Current

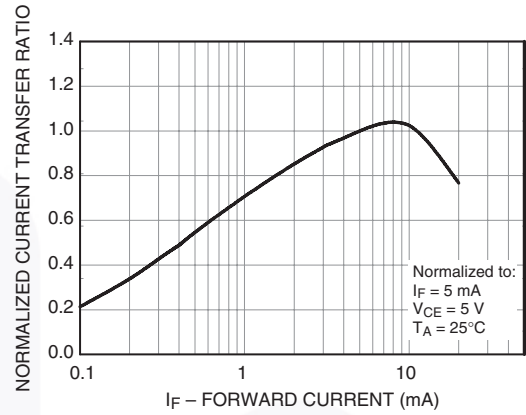

Figure 4. Normalized Current Transfer Ratio vs. Forward Current

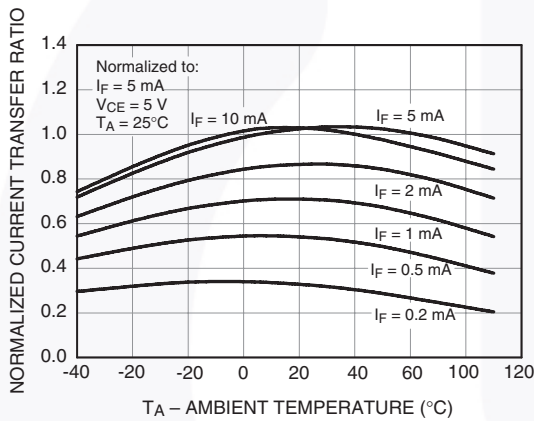

Figure 5. Normalized CTR vs. Temperature

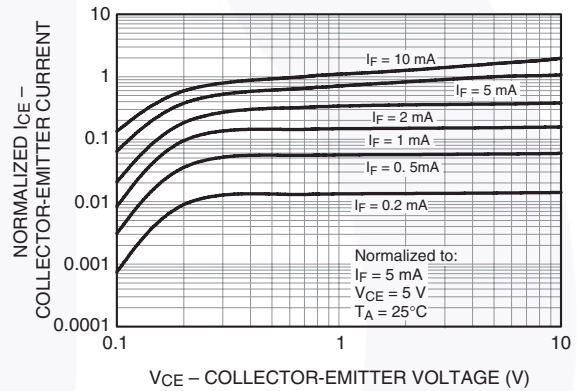

Figure 6. Normalized Collector vs. Collector-Emitter Voltage

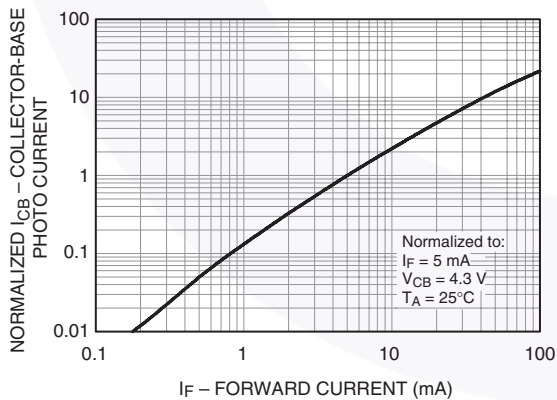

Figure 7. Normalized Collector Base Photocurrent Ratio vs. Forward Current

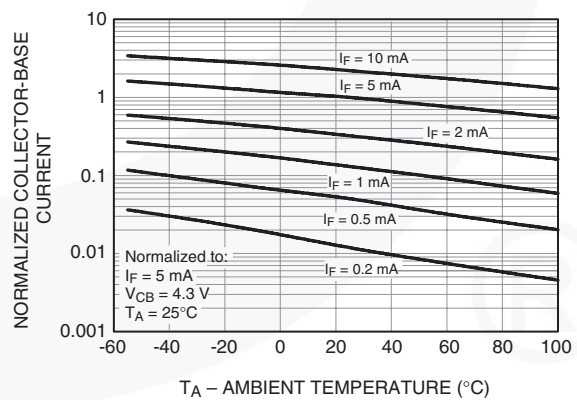

Figure 8. Normalized Collector-Base Current vs. Temperature

Typical Performance Curves (Continued)

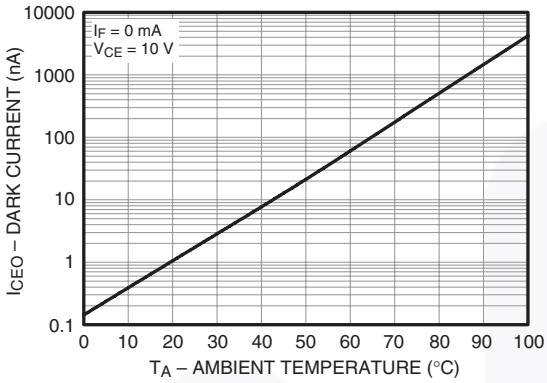

Figure 9. Collector-Emitter Dark Current vs. Ambient Temperature

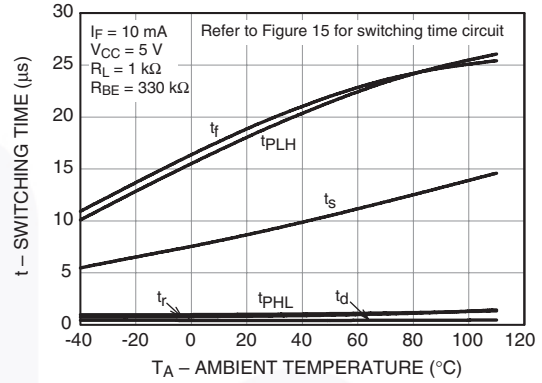

Figure 10. Switching Time vs. Ambient Temperature

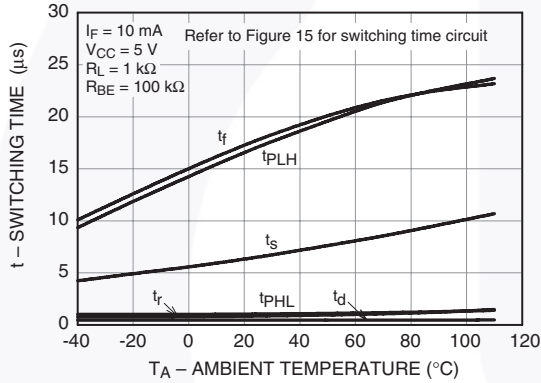

Figure 11. Switching Time vs. Ambient Temperature

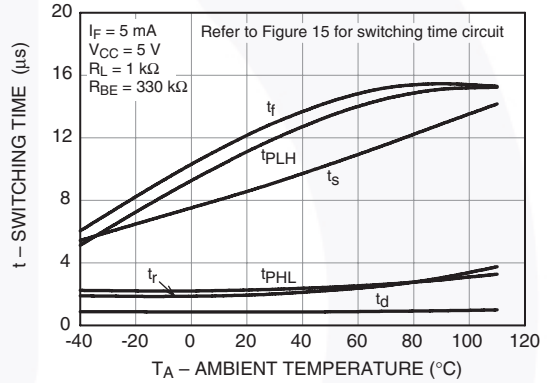

Figure 12. Switching Time vs. Ambient Temperature

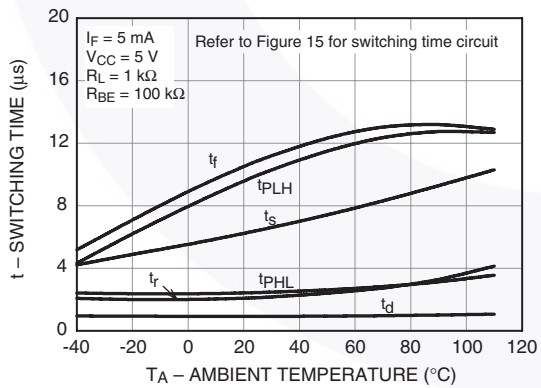

Figure 13. Switching Time vs. Ambient Temperature

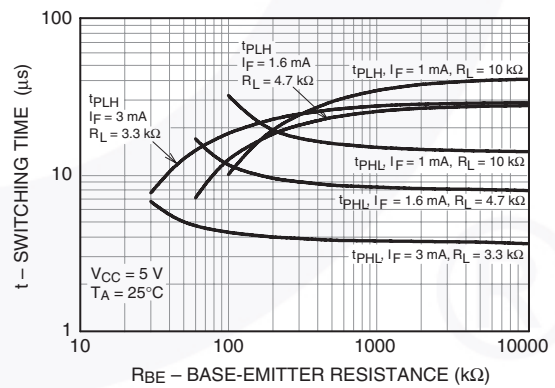

Figure 14. Switching Time vs. Base-Emitter Resistance

Switching Time Test Circuits and Waveforms

$T_A = 25^\circ\text{C}$ unless otherwise specified.

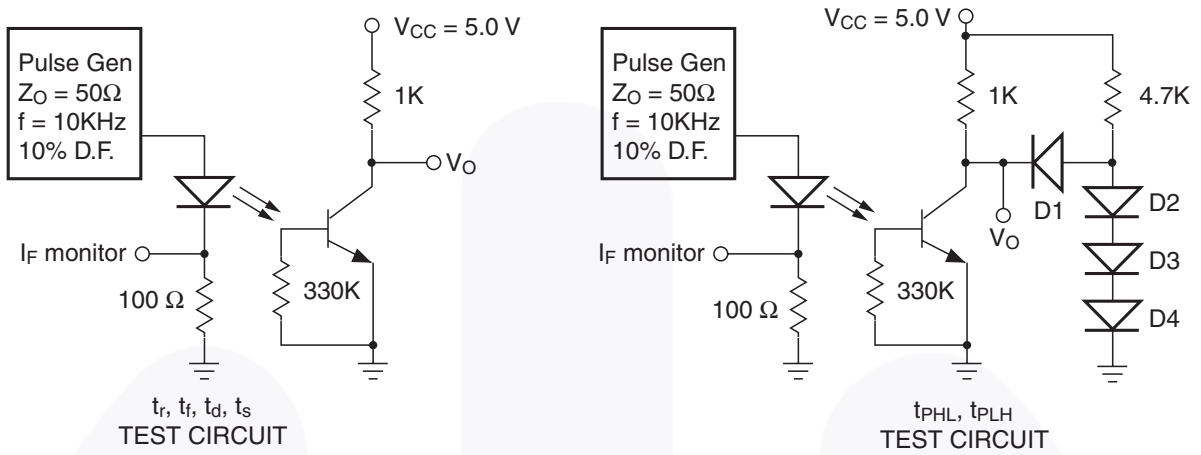

Figure 15. Switching Time Test Circuits

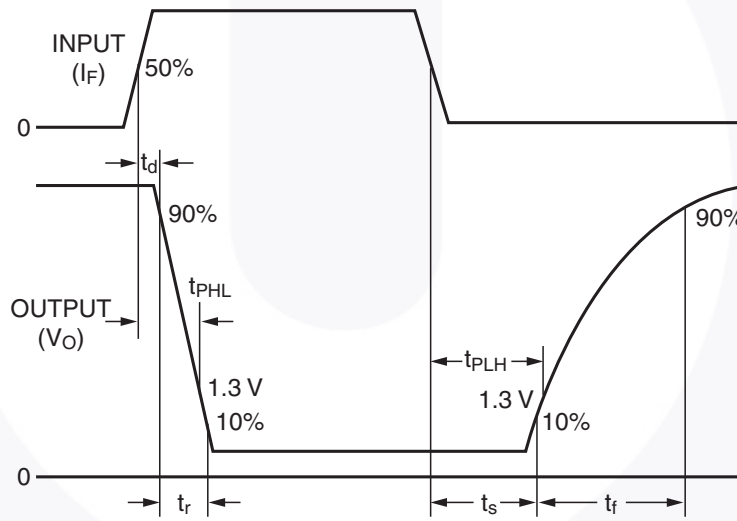

Figure 16. Switching Time Waveforms

Reflow Profile

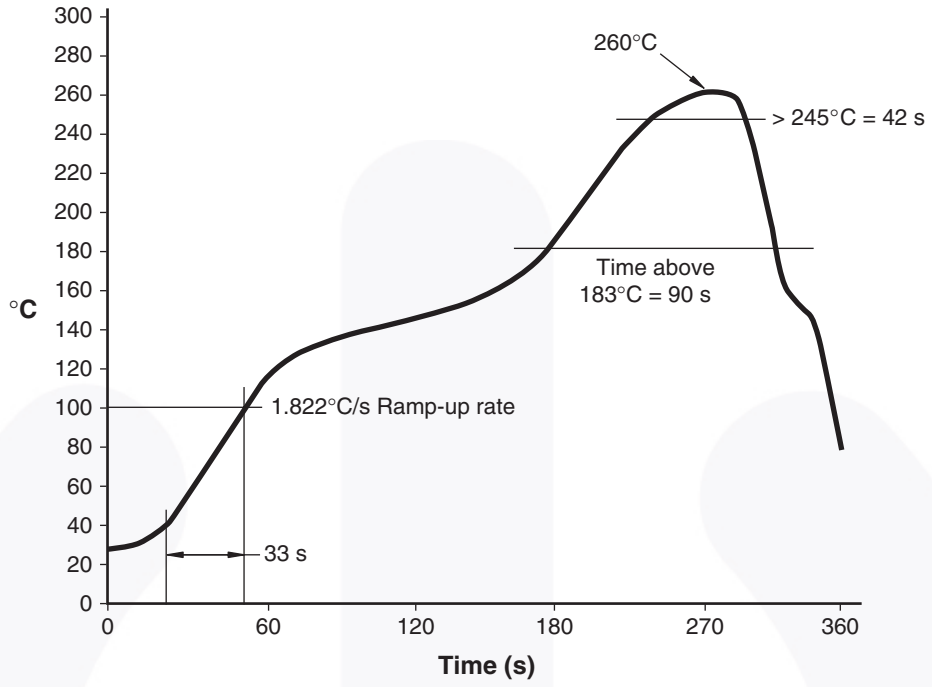

Figure 17. Reflow Profile



Ordering Information

Part Number	Package	Packing Method
MCT5210M	DIP 6-Pin	Tube (50 Units)
MCT5210SM	SMT 6-Pin (Lead Bend)	Tube (50 Units)
MCT5210SR2M	SMT 6-Pin (Lead Bend)	Tape and Reel (1000 Units)
MCT5210VM	DIP 6-Pin, DIN EN/IEC60747-5-5 Option	Tube (50 Units)
MCT5210SVM	SMT 6-Pin (Lead Bend), DIN EN/IEC60747-5-5 Option	Tube (50 Units)
MCT5210SR2VM	SMT 6-Pin (Lead Bend), DIN EN/IEC60747-5-5 Option	Tape and Reel (1000 Units)
MCT5210TVM	DIP 6-Pin, 0.4" Lead Spacing, DIN EN/IEC60747-5-5 Option	Tube (50 Units)

Note:

8. The product orderable part number system listed in this table also applies to the MCT5211M device.

Marking Information

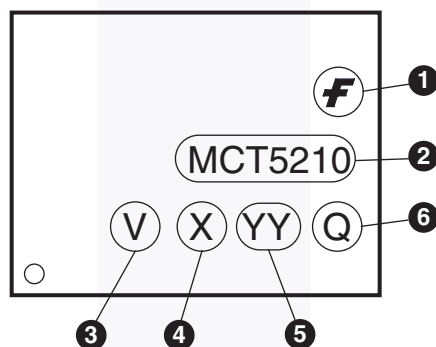
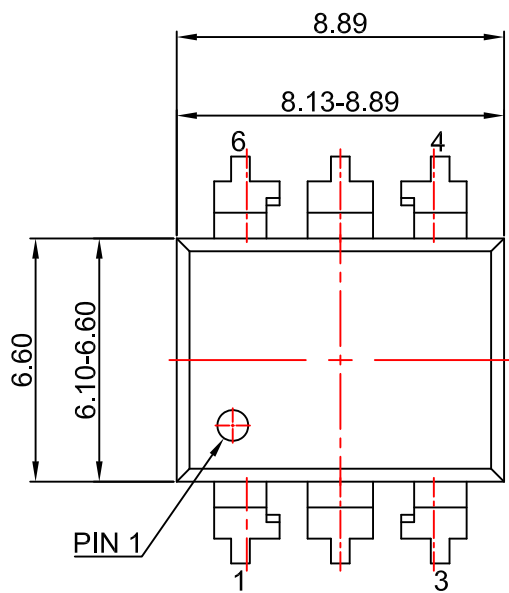

Figure 18. Top Mark

Table 1. Top Mark Definitions

1	Fairchild Logo
2	Device Number
3	DIN EN/IEC60747-5-5 Option (only appears on component ordered with this option)
4	One-Digit Year Code, e.g., "5"
5	Digit Work Week, Ranging from "01" to "53"
6	Assembly Package Code



NOTES:

- A) NO STANDARD APPLIES TO THIS PACKAGE.
- B) ALL DIMENSIONS ARE IN MILLIMETERS.
- C) DIMENSIONS ARE EXCLUSIVE OF BURRS, MOLD FLASH, AND TIE BAR EXTRUSION
- D) DRAWING FILENAME AND REVISION: MKT-N06BREV4.





LAND PATTERN RECOMMENDATION



NOTES:

- A) NO STANDARD APPLIES TO THIS PACKAGE.
- B) ALL DIMENSIONS ARE IN MILLIMETERS.
- C) DIMENSIONS ARE EXCLUSIVE OF BURRS, MOLD FLASH, AND TIE BAR EXTRUSION
- D) DRAWING FILENAME AND REVISION : MKT-N06CREV4.





NOTES:

- A) NO STANDARD APPLIES TO THIS PACKAGE.
- B) ALL DIMENSIONS ARE IN MILLIMETERS.
- C) DIMENSIONS ARE EXCLUSIVE OF BURRS, MOLD FLASH, AND TIE BAR EXTRUSION
- D) DRAWING FILENAME AND REVISION: MKT-N06Drev4





TRADEMARKS

The following includes registered and unregistered trademarks and service marks, owned by Fairchild Semiconductor and/or its global subsidiaries, and is not intended to be an exhaustive list of all such trademarks.

- | | | | |
|--------------------------|--|---------------------------------------|------------------|
| AccuPower™ | F-PFS™ | OPTOPLANAR® | SYSTEM GENERAL® |
| AttitudeEngine™ | FRFET® | Power Supply WebDesigner™ | TinyBoost® |
| Awinda® | Global Power Resource SM | PowerTrench® | TinyBuck® |
| AX-CAP®* | GreenBridge™ | PowerXS™ | TinyCalc™ |
| BitSiC™ | Green FPS™ | Programmable Active Droop™ | TinyLogic® |
| Build it Now™ | Green FPS™ e-Series™ | QFET® | TINYOPTO™ |
| CorePLUS™ | Gmax™ | QS™ | TinyPower™ |
| CorePOWER™ | GTO™ | Quiet Series™ | TinyPWM™ |
| CROSSVOL™ | IntelliMAX™ | RapidConfigure™ | TinyWire™ |
| CTL™ | ISOPLANAR™ | Saving our world, 1mW/W/kW at a time™ | TranSiC™ |
| Current Transfer Logic™ | Making Small Speakers Sound Louder and Better™ | SignalWise™ | TriFault Detect™ |
| DEUXPEED® | MegaBuck™ | SmartMax™ | TRUECURRENT®* |
| Dual Cool™ | MICROCOUPLER™ | SMART START™ | μSerDes™ |
| EcoSPARK® | MicroFET™ | Solutions for Your Success™ | UHC® |
| EfficientMax™ | MicroPak™ | SPM® | Ultra FRFET™ |
| ESBC™ | MicroPak2™ | STEALTH™ | UniFET™ |
| F [®] | MillerDrive™ | SuperFET® | VCX™ |
| Fairchild® | MotionMax™ | SuperSOT™-3 | VisualMax™ |
| Fairchild Semiconductor® | MotionGrid® | SuperSOT™-6 | VoltagePlus™ |
| FACT Quiet Series™ | MTi® | SuperSOT™-8 | XST™ |
| FACT® | MTx® | SupreMOS® | Xsens™ |
| FastvCore™ | MVN® | SyncFET™ | 仙童™ |
| FETBench™ | mWSaver® | Sync-Lock™ | |
| FPS™ | OptoHiT™ | | |
| | OPTOLOGIC® | | |

* Trademarks of System General Corporation, used under license by Fairchild Semiconductor.

DISCLAIMER

FAIRCHILD SEMICONDUCTOR RESERVES THE RIGHT TO MAKE CHANGES WITHOUT FURTHER NOTICE TO ANY PRODUCTS HEREIN TO IMPROVE RELIABILITY, FUNCTION, OR DESIGN. TO OBTAIN THE LATEST, MOST UP-TO-DATE DATASHEET AND PRODUCT INFORMATION, VISIT OUR WEBSITE AT [HTTP://WWW.FAIRCHILDSEMI.COM](http://www.fairchildsemi.com). FAIRCHILD DOES NOT ASSUME ANY LIABILITY ARISING OUT OF THE APPLICATION OR USE OF ANY PRODUCT OR CIRCUIT DESCRIBED HEREIN; NEITHER DOES IT CONVEY ANY LICENSE UNDER ITS PATENT RIGHTS, NOR THE RIGHTS OF OTHERS. THESE SPECIFICATIONS DO NOT EXPAND THE TERMS OF FAIRCHILD'S WORLDWIDE TERMS AND CONDITIONS, SPECIFICALLY THE WARRANTY THEREIN, WHICH COVERS THESE PRODUCTS.

AUTHORIZED USE

Unless otherwise specified in this data sheet, this product is a standard commercial product and is not intended for use in applications that require extraordinary levels of quality and reliability. This product may not be used in the following applications, unless specifically approved in writing by a Fairchild officer: (1) automotive or other transportation, (2) military/aerospace, (3) any safety critical application – including life critical medical equipment – where the failure of the Fairchild product reasonably would be expected to result in personal injury, death or property damage. Customer's use of this product is subject to agreement of this Authorized Use policy. In the event of an unauthorized use of Fairchild's product, Fairchild accepts no liability in the event of product failure. In other respects, this product shall be subject to Fairchild's Worldwide Terms and Conditions of Sale, unless a separate agreement has been signed by both Parties.

ANTI-COUNTERFEITING POLICY

Fairchild Semiconductor Corporation's Anti-Counterfeiting Policy. Fairchild's Anti-Counterfeiting Policy is also stated on our external website, www.fairchildsemi.com, under Terms of Use

Counterfeiting of semiconductor parts is a growing problem in the industry. All manufacturers of semiconductor products are experiencing counterfeiting of their parts. Customers who inadvertently purchase counterfeit parts experience many problems such as loss of brand reputation, substandard performance, failed applications, and increased cost of production and manufacturing delays. Fairchild is taking strong measures to protect ourselves and our customers from the proliferation of counterfeit parts. Fairchild strongly encourages customers to purchase Fairchild parts either directly from Fairchild or from Authorized Fairchild Distributors who are listed by country on our web page cited above. Products customers buy either from Fairchild directly or from Authorized Fairchild Distributors are genuine parts, have full traceability, meet Fairchild's quality standards for handling and storage and provide access to Fairchild's full range of up-to-date technical and product information. Fairchild and our Authorized Distributors will stand behind all warranties and will appropriately address any warranty issues that may arise. Fairchild will not provide any warranty coverage or other assistance for parts bought from Unauthorized Sources. Fairchild is committed to combat this global problem and encourage our customers to do their part in stopping this practice by buying direct or from authorized distributors.

PRODUCT STATUS DEFINITIONS

Definition of Terms

Datasheet Identification	Product Status	Definition
Advance Information	Formative / In Design	Datasheet contains the design specifications for product development. Specifications may change in any manner without notice.
Preliminary	First Production	Datasheet contains preliminary data; supplementary data will be published at a later date. Fairchild Semiconductor reserves the right to make changes at any time without notice to improve design.
No Identification Needed	Full Production	Datasheet contains final specifications. Fairchild Semiconductor reserves the right to make changes at any time without notice to improve the design.
Obsolete	Not In Production	Datasheet contains specifications on a product that is discontinued by Fairchild Semiconductor. The datasheet is for reference information only.

Rev. I76