



# SWITCHBOARD INSTRUMENTS



YOKOGAWA



## SWITCHBOARD INSTRUMENTS



### AB/DB40-METAL CASE

The industry standard for 4 1/4" switchboard instruments. Features include weathertight construction, and interchangeable scales, and optional illumination for ammeters and voltmeters.



### AB/DB16-8 3/4" CASE

This instrument is easily readable from distances over 30 feet. Available in the same ratings as the AB/DB40.



### AB/DB17-ILLUMINATED

An internally illuminated meter primarily used in high-vibration applications such as railroad and off-road vehicles. Available in Ammeter and Voltmeter configurations.



### AB/DB14-HIGH SHOCK

AB/DB14 Ammeters and Voltmeters are supplied in accordance with military specifications MIL-S-901 and MIL-M-16034. Primary application is for high shock conditions such as shipboard control panels.



### AB/DB40-PLASTIC CASE

Low-cost plastic case Ammeters and Voltmeters that meet ANSI C39.1. These meters offer the same high quality and reliability as the AB/DB40 at a substantial price difference.



### 2180-MINIATURE CASE

Type 2180 switchboard instruments offer 250° scale resolution and 1.5% full scale accuracy. The 3 1/4" face takes up less panel space than conventional switchboard meters.



### 180-EDGEWISE

Type 180 meters are available in horizontal and vertical mounting configurations. Internal illumination is available as an option.



### DUAL-VUE METERS

The DualVue series of switchboard meters accepts inputs of AC or DC voltage or current. They provide a convenient combination of an analog scale and digital readout in a rugged switchboard meter case with IP54 rated cover.



### RUDDER METER

This series of back-lit meters provides a continuous analog indication of the rudder position of a boat or ship based on an input signal from a position transducer.

## ADDITIONAL YOKOGAWA PRODUCTS



### PANEL METERS

Yokogawa has the broadest line of panel meters available today. The New Big Look, Horizon and Stylist series of meters are RoHS compliant. UL and IP54 splash resistant models are available. Request catalog 250260PB-B for more information.



### POWER SERIES PLUS

The POWER SERIES<sup>Plus</sup> digital switchboard meter was developed by Yokogawa to provide our customers with a versatile AC digital power meter. Requested catalog PSP-03B for more information.



### CLAMP-ON POWER METERS

Yokogawa CW240 and CW120 Clamp-on power meters provide convenient tools for monitoring power quality and energy consumption. A powerful data analysis software program is also available. Request catalog CW-E for more information.



### LOOP POWERED INDICATORS

Yokogawa provides many styles of analog and Digital loop powered indicators. Request catalog BULOOP-01E-A for more information.



### PR300 POWER & ENERGY METER

Yokogawa POWERCERT PR300 power & energy Meter provides a panel-mounted power and energy consumption monitoring meter with a large three-line display, RS-485 (Modbus/PC link) and Ethernet communication. Request catalog BU77C01A02-E for more information.



### CONTRACT MANUFACTURING

Yokogawa Corporation of America is a turnkey operation for both electrical and mechanical products. Your product can be produced at the highest level of quality and at a competitive price, with delivery to you or your customer anywhere in the world. Request the Contract Manufacturing catalog for more information.



### ADDITIONAL YOKOGAWA PRODUCTS



#### **XL120 PORTABLE DATA ACQUISITION**

Yokogawa Datum-Y™ Portable Data Station provides a compact Data logger with high noise immunity and powerful communication features. Request catalog XL120-E for more information.



#### **CA150 CALIBRATORS**

Yokogawa CA150 Handy Calibrator is a multi-functional hand-held calibrator with high accuracy that can measure and perform as a source simultaneously. Request catalog CA150-E for more information.



#### **INSULATION TESTERS**

Yokogawa insulation testers are battery powered and available in single and multiple range models in analog or digital versions. Request catalog MY-E for more information.



#### **800PLUS DIGITAL PANEL METERS & COUNTERS**

Yokogawa Corporation of America 800<sup>plus</sup> series provides universal digital panel meters for measurement and display of electrical, thermocouple, RTD, strain gauge, load cell and process signals and digital counters for measurement of frequency, period, rate, total integration, square root, quadrature and more. Request catalog 800SG-01C for more information.



#### **POWER TRANSDUCERS**

Yokogawa Juxta Power Transducers are UL recognized and enclosed in a rugged metal case. Both 0.2% and 0.5% models are available. Request catalog BU-JAC-07E for more information.



#### **DIGITAL MULTIMETERS**

Yokogawa digital multimeters are available in 3.5 and 4.5 digit hand-held models. TY700 Series has a DC voltage measurement accuracy of 0.02%. Request catalog DMM-E for more information.

Key to AB/DB Switchboard Numbering System (See Notes)

103	01	1	XX	XX	7*	XXX
<p><b>Digits 1, 2, &amp; 3 Type</b>                  101-TB-AB/DB14                  102-P&amp;J AB/DB17                  103-TB-AB/DB40                  106-P&amp;J-AB40 Synch.                  120-P&amp;J-AB16 Synch.                  121-TB-AB/DB16                  123-D-V Red LED                  124-D-V Green LED                  125-D-V Blue LED                  D-V= Dual-Vue                  126-Red back-lit 103                  127-White back-lit 103</p>	<p><b>Digits 4 &amp; 5 Measured Qty.</b>                  01-DC Volts                  02-AC Volts                  07 Voltmeter (expanded scale)                  11-DC Amps                  12-DC Millivolts                  13-AC Amps                  15-AC voltmeter (rectifier type)                  19-Supp. Zero                  21-2W1P Watts 1 EL                  22-3W3P Watts 2 EL                  25-4W3P Watts 2½ EL                  28-3W3P Vars (cross phase) 2 EL                  29-4W3P Vars (cross phase) 2½ EL                  31-2W1P Vars 1 EL                  32-3W3P Vars (external phase shifter) 2 EL                  34-4W3P Vars (external phase shifter) 2½ EL                  37-Freq. Meter                  40-Power Factor 3W3P &amp; 4W3P (balanced)                  41-Power Factor 2W1P                  45-Synchroscope                  46-Power Factor-3W3P (unbalanced)                  47-Power Factor-4W3P (unbalanced)                  50-Temp. Ind.                  55-DC Voltmeter (ground detector type)                  62-DC Tach. Ind.                  63-AC Tach. Ind.                  70-2W1P Watts • 1 EL                  71-3W3P Watts • 2 EL                  73-4W3P Watts • 2 ½ EL                  74-4W3P Vars • (cross phase) 2½ EL                  76-2W1P Vars • 1 EL                  77-3W3P Vars • (for use w/external phase shifter) 2 EL                  79-4W3P Vars • (for use w/external phase shifter) 2½ EL                  81-3W3P Vars • 2 EL (cross PH)</p>	<p><b>Digit 6 Mechanical Features</b>                  1-Zero left, black cover                  2-Zero center, black cover                  3-Zero left, gray cover                  4-Zero center, gray cover                  5-Zero left, antiglare, black cover                  6-Zero center, antiglare, black cover</p>	<p><b>Digits 7 &amp; 8 - Elec. Rtg.</b>                  Ex: LA = 1A                  LE = 2A                  LS = 5A                  (see note 2)</p>	<p><b>Digits 9 &amp; 10 - Scale</b>                  Ex: FA = 0-1mA                  FX = 0-5mA                  (see note 2)</p>	<p><b>*Digit 11 - Factory Style No. For factory use.</b>                  Not used for models 123, 124, or 125</p> <p><b>Digit 11 for models 123, 124, 125</b>                  1=120VAC                  2=240VAC                  3=125VDC                  4=24VDC                  5=48VDC</p>	<p><b>Digits 12, 13 &amp; 14-Spcl Units</b>                  When used, these denote unique models. Refer to factory for details. For Wattmeters &amp; Varmeters, see pages 18-23.</p> <p><b>Digits 12, 13 &amp; 14 for models** 126:</b>                  R06=6VDC                  R12=12VDC                  R24=24-28VDC                  R48=48VDC</p> <p><b>127:</b>                  W06=6VDC                  W12=12VDC                  W24=24VDC                  W48=48VDC                  **not used if other unique features are included.</p>

**NOTES:**

1. This tabulation is not all inclusive, to be used for defining cat. nos. only
2. For watt & var cat. nos. digits 7-10 & 12-14 designate rating-cal watts-scale & legend information

3. TB = taut band movement
4. P&J = pivot & jewel movement
5. "P" suffix denotes plastic case
  - Low Cal Watts, Zero Center
6. Back-lit is available in red or white on models 103 01, 02, 07, 11, 12 and 16

**How to Order — Specify the following:**

1. Complete catalog number, or;
2. Provide significant portion of catalog number with word description for differences (e.g. "Similar to 103111FAFA, except scale 0-100 kilovars"), or
3. Provide word description including the following information:  
 Type: AB/DB-14, 16, or 40  
 Rating (Input):.....Amperes AC or DC .....  
 Volts AC or DC .....  
 Frequency: 60 Hz, 50 Hz, 400 Hz .....Hz  
 Scale: Min. Value - Max. Value, Zero left, Zero-center or offset zero  
 Legend: Specify words and/or symbols exactly  
 Potential Transformer Ratio: .....to 120 volts or .....to .....volts  
 Current Transformer Ratio: .....to 5 amperes or .....to .....amperes  
 Circuit: 2-wire/single-phase, 3-wire/3 phase.  
 3-phase/4-wire.....other  
 External Devices; phase Shifting transformers, shunts transducers, etc.....  
 Other Options:.....  
 Special features .....

**Shipping & Storage Weights**

Instrument	*AD/DB-40				AD/DB-16				
	Net		Ship		Net		Ship		
	(lbs)	(kg)	(lbs)	(kg)	(lbs)	(kg)	(lbs)	(kg)	
DC-A/V	1.5	.70	2.4	1.1	3.0	1.4	5.0	2.2	
AC	V	1.7	.79	2.7	1.2	3.4	1.5	5.0	2.2
	A	1.8	.84	2.7	1.2	3.4	1.5	5.0	2.3
WATT/ VAR	1ø	2.8	1.3	3.6	1.7	4.4	2.0	6.0	2.8
	3ø3W	3.0	1.4	3.9	1.8	4.6	2.1	6.3	2.9
	3ø4W								
Power Factor	2.0	.95	3.0	1.4	3.6	1.7	5.3	2.4	
Frequency	1.8	.82	2.7	1.2	3.3	1.5	5.0	2.3	
Temperature	2.0	.95	3.0	1.4	3.6	1.7	5.3	2.4	
Tachometer	1.6	.80	2.7	1.2	3.3	1.5	5.0	2.3	
Synchroscope	1.7	.77	2.0	.91	3.1	1.4	4.0	1.8	

\*Subtract 0.5 lbs. for plastic case amp & volt.

**Approximate Package Size in Inches / Centimeters**

All AB/DB (Except AB-/DB-16).....	6 x 6 x 11 / 15 x 15 x 28
Shipping.....	7 x 7 x 13 / 18 x 18 x 33
AB-/DB-16 .....	10 x 10 x 11 / 25 x 25 x 28
Shipping.....	11 x 11 x 13 / 28 x 28 x 33

SWITCHBOARD INSTRUMENT SELECTOR GUIDE

Model Type	AB/DB40	AB/DB40	AB/DB16	Dual-Vue	AB/DB17	AB40 Hour	AB/DB14	T/180	T/2180
Case style	4¼" Metal	4¼" Plastic	8¾"	4 1/4" Metal	Illuminated	Meters	High-shock	6" Edgewise	Mini-swbd.
<b>Input rating</b>									
AC Milliamperes	X	X	X	N/A	N/A	N/A	X	X	X
AC Amperes	X	X	X	X	N/A	N/A	X	X	X
AC Voltage	X	X	X	X	N/A	X	X	X	X
DC Microamperes	X	X	X	N/A	N/A	N/A	X	X	X
DC Milliamperes	X	X	X	N/A	X	N/A	X	X	X
DC Amperes	X	X	X	X	X	N/A	X	X	X
DC Millivolts	X	X	X	N/A	X	N/A	X	X	X
DC Voltage	X	X	X	X	X	N/A	X	X	N/A
Frequency	X	*	X	N/A	N/A	N/A	*	*	X
AC Watts	X	*	X	N/A	N/A	N/A	*	*	*
AC VARS	X	*	X	N/A	N/A	N/A	*	*	*
Power Factor	X	*	X	N/A	N/A	N/A	*	*	X
RTD Temperature	X	*	X	N/A	*	N/A	*	*	*
AC Synchroscope	X	N/A	X	N/A	N/A	N/A	N/A	N/A	N/A
RPM Indicator	X	X	X	N/A	X	N/A	X	X	X
Process indicator	X	X	X	N/A	X	N/A	X	X	X
Ground detector	X	X	X	N/A	X	N/A	N/A	X	X
Back-lit	X	N/A	N/A	N/A	N/A	N/A	N/A	N/A	N/A

Notes: \* Requires external transducer, X = available, N/A = Not available in this model, † = rectifier type.

**AB/DB Switchboard specifications in accordance with ANSI C39.1**

**Accuracy:** ±1.0% of full scale basic accuracy class.  
*Specific accuracies:*  
 Rectifier type meter- ±1.5% @ 25°C calibrated to sine wave.  
 Expanded Scale Voltmeter- 0.3% of mid-scale.  
 Power factor meter- ±1% of scale length from 20-100% of rated current on balanced system models; ±3% of scale length on unbalanced system model types.  
 Synchroscope- ±1% of scale length.  
 Frequency meters- ± .15Hz @45-55Hz and 55-65Hz, ±0.093Hz @ 58-62Hz, ±1.5Hz @350-450Hz.  
**Position of use:** Vertical (scale)  
**Full scale deflection angle:** 250°, except synchroscope is 360°  
**Full scale length:**  
 AB/DB40, AB/DB14, AB/DB17- 6.9 inches.  
 AB/DB16- 13.8 inches.  
**Scale plate:** AB/DB40, AB/DB14 platform type 2 piece scale with graduations on the outer scale; numerals and legends on the inner scale or one-piece lasered scale (standard). AB/DB16, has a one piece platform scale or flat lasered scale (standard), AB/DB17 see page 14.  
**Case:** All AB/DB switchboard instruments have drawn steel case with zinc chromate coating except AB/DB40 plastic case which is ABS.  
**Cover:** AB/DB14, AB/DB17 metal cover with polycarbonate window. AB/DB16, AB/DB40 polycarbonate-UL94V-0 cover and window.  
**Terminal plate:** phenol resin material.  
**Mounting studs:** 1/4" x 28 thread.  
**Terminal studs:** 10-32 thread.  
**Operating temperature range:** 0 to 40°C (32 to 104°F).  
**Storage temperature range:** -10 to 50°C (14 to 122°F).  
**Extreme temperature range:** -20°C to 65°C (-4 to 149°F).  
**Dielectric level:** 2300VAC for 1 minute between the electrical circuit and mounting studs.  
**Overload rating:** Voltmeter and potential coils-1.2 x rating (continuous). AC Ammeters- 2 x rating (continuous), and 10 x rating for one second. Current coils (other than ammeters) 1.5 x rating (continuous), and 10 x rating for one second.  
**Response time:** Approximately 2.5 seconds (except AB/DB16)  
**UL File:** E91703

**CONTENTS**

**AB/DB Switchboard Instruments**

Page 5	Key to Switchboard numbering system, how to order, shipping and storage weights.
Page 6	Selector guide, general specifications, catalog contents.
Page 7-10	AC/DC Ammeters, Voltmeters, Tach. indicators.
Page 11-13	Dual-Vue meters.
Page 14	DB17 general ratings and specifications.
Page 15	Power Factor, Frequency meters, Synchrosopes, Temperature meters.
Page 16	AB40 Hour meter.
Page 17	AC Wattmeters and Varmeters.
Page 18-23	Application guide for selection of Wattmeters and Varmeters.
Page 24	Optional features for AB/DB40 and AB/DB16.
Page 25	Switchboard minimum / maximum ratings.
Page 26	Switchboard specification and burden data.
Page 27-29	Standard connection drawings for AB/DB40 and AB/DB16.
Page 30-33	Dimensions and panel cutout drawings.

**Type 180 Edgewise Instruments.**

Page 34-36	General specifications, catalog numbers, Optional features, dimensions and cutouts.
------------	---

**Type 2180 Miniature Switchboard Instruments**

Page 37-38	General specifications, ordering information, dimensions and panel cutout.
------------	--

**Rudder Meter**

Page 39-40	General specifications, catalog numbers, Optional features, dimensions and cutouts.
------------	---



**AB-40  
Metal Case**



**AB-40  
Plastic Case**

**AC Ammeters**

Rating (Amperes)	Scale (Amperes)	AB-14 Cat. No.	AB-40 Metal Case	AB-40 Plastic Case	AB-16 Cat. No.
<b>Self-Contained, 40/70 Hz</b>					
1	0-1	101 133 LALA	103 131 LALA	103 131 LALA7/P	121 131 LALA
1.5	0-1.5	101 133 LCLC	103 131 LCLC	103 131 LCLC7/P	121 131 LCLC
2	0-2	101 133 LELE	103 131 LELE	103 131 LELE7/P	121 131 LELE
3	0-3	101 133 LJLJ	103 131 LJLJ	103 131 LJLJ7/P	121 131 LJLJ
5	0-5	101 133 LSL5	103 131 LSL5	103 131 LSL57/P	121 131 LSL5
7.5	0-7.5	101 133 MFMF	103 131 MFMF	103 131 MFMF7/P	121 131 MFMF
10	0-10	101 133 MTMT	103 131 MTMT	103 131 MTMT7/P	121 131 MTMT
15	0-15	101 133 NDND	103 131 NDND	103 131 NDND7/P	121 131 NDND
20	0-20	101 133 NGNG	103 131 NGNG	103 131 NGNG7/P	121 131 NGNG
30	0-30	101 133 NLNL	103 131 NLNL	103 131 NLNL7/P	—
<b>Transformer-Rated, 40/70Hz</b>					
5	0-10	101 133 LSMT	103 131 LSMT	103 131 LSMT7/P	121 131 LSMT
5	0-15	101 133 LSND	103 131 LSND	103 131 LSND7/P	121 131 LSND
5	0-20	101 133 L5NG	103 131 L5NG	103 131 L5NG7/P	121 131 L5NG
5	0-25	101 133 L5NJ	103 131 L5NJ	103 131 L5NJ7/P	121 131 L5NJ
5	0-30	101 133 L5NL	103 131 L5NL	103 131 L5NL7/P	121 131 L5NL
5	0-40	101 133 L5NP	103 131 L5NP	103 131 L5NP7/P	121 131 L5NP
5	0-50	101 133 L5NT	103 131 L5NT	103 131 L5NT7/P	121 131 L5NT
5	0-75	101 133 L5PB	103 131 L5PB	103 131 L5PB7/P	121 131 L5PB
5	0-100	101 133 L5PK	103 131 L5PK	103 131 L5PK7/P	121 131 L5PK
5	0-150	101 133 L5PZ	103 131 L5PZ	103 131 L5PZ7/P	121 131 L5PZ
5	0-200	101 133 L5RL	103 131 L5RL	103 131 L5RL7/P	121 131 L5RL
5	0-250	101 133 L5RS	103 131 L5RS	103 131 L5RS7/P	121 131 L5RS
5	0-300	101 133 L5RX	103 131 L5RX	103 131 L5RX7/P	121 131 L5RX
5	0-400	101 133 L5SC	103 131 L5SC	103 131 L5SC7/P	121 131 L5SC
5	0-500	101 133 L5SF	103 131 L5SF	103 131 L5SF7/P	121 131 L5SF
5	0-600	101 133 L5SJ	103 131 L5SJ	103 131 L5SJ7/P	121 131 L5SJ
5	0-800	101 133 L5SN	103 131 L5SN	103 131 L5SN7/P	121 131 L5SN
5	0-1000	101 133 L5SS	103 131 L5SS	103 131 L5SS7/P	121 131 L5SS
5	0-1200	101 133 L5SV	103 131 L5SV	103 131 L5SV7/P	121 131 L5SV
5	0-1500	101 133 L5TC	103 131 L5TC	103 131 L5TC7/P	121 131 L5TC
5	0-2000	101 133 L5TM	103 131 L5TM	103 131 L5TM7/P	121 131 L5TM
5	0-2500	101 133 L5TV	103 131 L5TV	103 131 L5TV7/P	121 131 L5TV
5	0-3000	101 133 L5UA	103 131 L5UA	103 131 L5UA7/P	121 131 L5UA
5	0-4000	101 133 L5UE	103 131 L5UE	103 131 L5UE7/P	121 131 L5UE
5	0-5000	101 133 L5UJ	103 131 L5UJ	103 131 L5UJ7/P	121 131 L5UJ
5	0-6000	101 133 L5UP	103 131 L5UP	103 131 L5UP7/P	121 131 L5UP
5	0-7000	101 133 L5US	103 131 L5US	103 131 L5US7/P	121 131 L5US
5	0-8000	101 133 L5UW	103 131 L5UW	103 131 L5UW7/P	121 131 L5UW
<b>Instruction Book: 4555K10P0701, Outline Dimensions: See pages 30 and 33</b>					

## SWITCHBOARD INSTRUMENTS



**AB-40  
Metal Case**



**AB-40  
Expanded Scale**

## AC Voltmeters

Rating (Volts)	Scale (Volts)	AB-14 Cat. No.	AB-40 Metal Case	AB-40 Plastic Case	AB-16 Cat. No.
<b>Self-Contained, 50/60 Hz</b>					
150	0-150	101 023 PZPZ	103 021 PZPZ	103 021 PZPZ7/P	121 021 PZPZ
250	0-250	101 023 RSRS	103 021 RSRS	103 021 RSRS7/P	121 021 RSRS
300	0-300	101 023 RXRX	103 021 RXRX	103 021 RXRX7/P	121 021 RXRX
500	0-500	101 023 SFSF	103 021 SFSF	103 021 SFSF7/P	121 021 SFSF
600	0-600	101 023 SJSJ	103 021 SJSJ	103 021 SJSJ7/P	121 021 SJSJ
750 <sub>s</sub>	0-750	**	103 021 SMSM	103 021 SMSM7/P	121 021 SMSM
<b>Transformer-Rated, 50/60 Hz</b>					
150	0-300	101 023 PZRZ	103 021 PZRZ	103 021 PZRZ7/P	121 021 PZRZ
150	0-600	101 023 PZSJ	103 021 PZSJ	103 021 PZSJ7/P	121 021 PZSJ
150	0-750	101 023 PZSM	103 021 PZSM	103 021 PZSM7/P	121 021 PZSM
150	0-3000	101 023 PZUA	103 021 PZUA	103 021 PZUA7/P	121 021 PZUA
150	0-5250	101 023 PZUL	103 021 PZUL	103 021 PZUL7/P	121 021 PZUL
150	0-6000	101 023 PZUP	103 021 PZUP	103 021 PZUP7/P	121 021 PZUP
150	0-9000	101 023 PZUY	103 021 PZUY	103 021 PZUY7/P	121 021 PZUY
150	0-15kV	101 023 PZWZ	103 021 PZWZ	103 021 PZWZ7/P	121 021 PZWZ
150	0-18kV	101 023 PZXE	103 021 PZXE	103 021 PZXE7/P	121 021 PZXE
150	0-45kV	101 023 PZXU	103 021 PZXU	103 021 PZXU7/P	121 021 PZXU
150	0-150kV	101 023 PZYR	103 021 PZYR	103 021 PZYR7/P	121 021 PZYR
250	0-600V	101 023 RSSJ	103 021 RSSJ	103 021 RSSJ7/P	121 021 RSSJ
<b>Expanded Scale, Self-Contained, 50/60 HZ</b>					
110-130	110-130	**	103 071 PNP	103 071 PNP7/P	121 071 PNP
<b>Expanded Scale, Transformer Rated, 50/60 HZ</b>					
110-130	†	**	103 071 PN . *	103 071 PN . 7/P*	121 071 PN . *
<b>Rectifier Type, 1.5% Accuracy, 20 to 3000 Hz</b>					
15	0-15	**	103151NDND	103151NDND 71P	121151NDND
30	0-30	**	103151NLNL	103151NLNL 71P	121151NLNL
150	0-150	**	103151PZPZ	103151PZPZ 71P	121151PZPZ
150	†	**	103151PZ*	103151PZ* 71P	121151PZ*
300	0-300	**	103151RXRX	103151RXRX 71P	121151RXRX
600	0-600	**	103151STST	103151STST 71P	121151SJSJ
<b>Ground Detector Type — Single-Phase 50/60 Hz</b>					
150	0-150	**	103 021 PZPZ	103 021 PZPZ7/P	121 021 PZPZ
150	†	**	103 021 PZ . *	103 021 PZ . *7/P	121 021 PZ . *
300	0-300	**	103 021 RXRX	103 021 RXRX7/P	121 021 RXRX
600	0-600	**	103 021 SJSJ	103 021 SJSJ7/P	121 021 SJSJ
<b>Instruction Book: 4555K10P0701, Outline Dimensions: see pages 30 and 33</b>					

<sub>s</sub> UL version not available.

\* Order by description. Specify P.T. (Potential Transformer) ratio if used, and scale desired.

\*\* High shock version not available.

† Scale per requisition. AB/DB models have maximum 4 digits as standard.



## DC Ammeters Self-Contained

Scale and Rating	DB-14 Cat. No.	DB-40 Metal Case	DB-40 Plastic Case	DB-16 Cat. No.
<b>Microammeters — Zero-Left</b>				
0-200	**	103 111 EAEA	103 111 EAEA7/P	—
0-300	101 113 EGE G	103 111 EGE G	103 111 EGE G7/P	121 111 EGE G
0-500	101 113 EMEM	103 111 EMEM	103 111 EMEM7/P	121 111 EMEM
<b>Milliammeters — Zero-Left</b>				
<sup>s</sup> 0-1	101 113 FAFA	103 111 FAFA	103 111 FAFA7/P	121 111 FAFA
0-2	101 113 FGFG	103 111 FGFG	103 111 FGFG7/P	121 111 FGFG
0-5	101 113 FFXF	103 111 FFXF	103 111 FFXF7/P	121 111 FFXF
0-10	101 113 GZGZ	103 111 GZGZ	103 111 GZGZ7/P	121 111 GZGZ
0-30	101 113 HMHM	103 111 HMHM	103 111 HMHM7/P	121 111 HMHM
0-50	101 113 HYHY	103 111 HYHY	103 111 HYHY7/P	121 111 HYHY
0-100	101 113 JRJR	103 111 JRJR	103 111 JRJR7/P	121 111 JRJR
0-200	101 113 KAKA	103 111 KAKA	103 111 KAKA7/P	121 111 KAKA
0-300	101 113 KGKG	103 111 KGKG	103 111 KGKG7/P	121 111 KGKG
0-500	101 113 KMKM	103 111 KMKM	103 111 KMKM7/P	121 111 KMKM
<b>Milliammeters — Suppressed-Zero (No zero set unless otherwise specified)</b>				
10-50	101 193 HX...†	103 191 HX...†	103 191 HX...†7/P	121 191 HX...†
<sup>s</sup> 4-20	101 193 HE...†	103 191 HE...†	103 191 HE...†7/P	121 191 HE...†
1-5	101 193 FY...†	103 191 FY...†	103 191 FY...†7/P	121 191 FY...†
<b>Ammeters — Zero-Left</b>				
0-1	101 113 LALA	103 111 LALA	103 111 LALA7/P	121 111 LALA
0-5	101 113 LSL S	103 111 LSL S	103 111 LSL S7/P	121 111 LSL S
0-10	101 113 MTMT	103 111 MTMT	103 111 MTMT7/P	121 111 MTMT
0-15	101 113 NDND	103 111 NDND	103 111 NDND7/P	121 111 NDND
0-20	101 113 NGNG	103 111 NGNG	103 111 NGNG7/P	121 111 NGNG
0-30	101 113 NLNL	103 111 NLNL	103 111 NLNL7/P	121 111 NLNL

**Instruction Book: 4555K10P0701, Outline Dimensions: see pages 23 and 24**

- <sup>s</sup> See page 34 and 35 for Matching Power Transducer or Isolator.
- † Scale per requisition. (AB/DB-40/16) have a maximum of 4 digits as standard.
- \*\* High shock version not available.

**DB-40 Metal Case**



**DB-40 Plastic Case**



## DC Ammeters Shunt-Rated

Rating (Millivolts)	Scale (Amperes)	DB-14 Cat. No.	DB-40 Metal Case	DB-40 Plastic Case	DB-16 Cat. No.
<b>With Lead Length Compensator, Catalog Number Does Not Include Shunt or Shunt Leads</b>					
50	*	**	103 121 AB...	103 121 AB...7/P	121 121 AB...
50-0-50	*	101 124 AB...	103 122 AB...	103 122 AB...7/P	121 122 AB...
100	*	101 123 AE...	103 121 AE...	103 121 AE...7/P	121 121 AE...
100-0-100	*	101 124 AE...	103 122 AE...	103 122 AE...7/P	121 122 AE...
<b>Zero-Left for Use with 50mV Shunts and 0.05-Ohm Shunt Leads, (Standard 5-Foot Leads). <sup>s</sup></b>					
<b>See page 37 for External Shunts (Shunts and Leads are not included with meter).</b>					
50	0-15	101 123 CAND	103 121 CAND	103 121 CAND7/P	121 121 ECND
50	0-20	101 123 CANG	103 121 CANG	103 121 CANG7/P	121 121 ECNG
50	0-30	101 123 CANL	103 121 CANL	103 121 CANL7/P	121 121 ECNL
50	0-40	101 123 CANP	103 121 CANP	103 121 CANP7/P	121 121 ECNP
50	0-50	101 123 CANT	103 121 CANT	103 121 CANT7/P	121 121 ECNT
50	0-75	101 123 CAPB	103 121 CAPB	103 121CAPB7/P	121 121 ECPB
50	0-100	101 123 CAPK	103 121 CAPK	103 121 CAPK7/P	121 121 ECPK
50	0-150	101 123 CAPZ	103 121 CAPZ	103 121 CAPZ7/P	121 121 ECPZ
50	0-200	101 123 CARL	103 121 CARL	103 121 CARL7/P	121 121 ECRL
50	0-300	101 123 CARX	103 121 CARX	103 121 CARX7/P	121 121 ECRX
50	0-400	101 123 CASC	103 121 CASC	103 121 CASC7/P	121 121 ECSC
50	0-500	101 123 CASF	103 121 CASF	103 121 CASF7/P	121 121 ECSF
50	0-750	101 123 CASM	103 121 CASM	103 121 CASM7/P	121 121 ECSM
50	0-1000	101 123 CASS	103 121 CASS	103 121 CASS7/P	121 121 ECSS
50	0-1200	101 123 CASV	103 121 CASV	103 121 CASV7/P	121 121 ECSV
50	0-1500	101 123 CATC	103 121 CATC	103 121 CATC7/P	121 121 ECTC
50	0-2000	101 123 CATM	103 121 CATM	103 121 CATM7/P	121 121 ECTM
50	0-3000	101 123 CAUA	103 121 CAUA	103 121 CAUA7/P	121 121 ECUA

**Instruction Book: 4555K10P0701, Outline Dimensions: see pages 30 and 33**

- \*\* High shock not available
- \* Scale marked in terms of shunt current. When ordering specify rating of shunt to be used, scale and legend. AB/DB meter scales have a maximum of 4 digits.
- <sup>‡</sup> Shunt-rated instruments are normally calibrated for 5-foot shunt leads (0.050 Ohms). They can be calibrated for maximum resistances as follows:  $\frac{50mV}{2.0\text{ Ohms}}$   $\frac{100mV}{5.0\text{ Ohms}}$

## DC Voltmeters

Rating and Scale (Volts)	DB-14 Cat. No.	DB-40 Metal Case	DB-40 Plastic Case	DB-16 Cat. No.
<b>Zero-Left (Sensitivity is 1000 OHMS / Volt)</b>				
0-15	101 013 NDND	103 011 NDND	103 011 NDND7/P	121 011 NDND
0-30	101 013 NLNL	103 011 NLNL	103 011 NLNL7/P	121 011 NLNL
0-50	101 013 NTNT	103 011 NTNT	103 011 NTNT7/P	121 011 NTNT
0-75	101 013 PBPB	103 011 PBPB	103 011 PBPB7/P	121 011 PBPB
0-150	101 013 PZPZ	103 011 PZPZ	103 011 PZPZ7/P	121 011 PZPZ
0-300	101 013 RXRX	103 011 RXRX	103 011 RXRX7/P	121 011 RXRX
0-400	101 013 SCSC	103 011 SCSC	103 011 SCSC7/P	121 011 SCSC
0-500	101 013 SFSF	103 011 SFSF	103 011 SFSF7/P	121 011 SFSF
0-600	101 013 SJSJ	103 011 SJSJ	103 011 SJSJ7/P	121 011 SJSJ
<b>Zero-Center (Sensitivity is 2000 OHMS / Volt)</b>				
150-0-150	101 014 PZPZ	103 012 PZPZ	103 012 PZPZ7/P	121 012 PZPZ
300-0-300	101 014 RXRX	103 012 RXRX	103 012 RXRX7/P	121 012 RXRX
500-0-500	101 014 SFSF	103 012 SFSF	103 012 SFSF7/P	121 012 SFSF
600-0-600	101 014 SJSJ	103 012 SJSJ	103 012 SJSJ7/P	121 012 SJSJ
<b>Ground Detector Type — Zero-Center for 2-Wire Circuits (Standard Sensitivity is 1000 OHMS/Volt) ‡</b>				
150-0-150	**	103 552 PZ†	103 552 PZ†7/P	121 552 PZ†
300-0-300	**	103 552 RX†	103 552 RX†7/P	121 552 RX†
500-0-500	**	103 552 SF†	103 552 SF†7/P	121 552 SF†
600-0-600	**	103 552 SJ†	103 552 SJ†7/P	121 552 SJ†
<b>Instruction Book: 4555K10P0701, Outline Dimensions pages 30 and 34</b>				

† Specify scale by order.

‡ Includes (2) 2227 External Resistors.

\*\* High shock version not available.

## Tachometer Indicators

### DC Volts 103621RR55

Select nearest higher rated DC Voltmeter from above and specify requirements.

### AC Volts 103631RR55

Select nearest higher rated rectifier type AC voltmeter from Page 8 and specify requirements.

**Instruction Book 4555K15P0003**

**DB-40 Tachometer**



**DB-40 Metal Case**



**DB-40 Plastic Case**



## DUAL-VUE

- Features analog and digital display to provide the ultimate in readability of power and control parameters.
- A drop-in replacement for upgrade of existing control and switchgear panels.
- Rugged switchboard style case and IP54 rated cover.
- Choice of high-intensity LED digital displays with high reliability analog movements.
- Standard models for AC or DC voltage and current, with custom scales and legends available as options.

### DUAL-VUE switchboard meter specifications:

#### General Description

**DUAL-VUE** switchboard meters are combination Digital/Analog indicating instruments. They can be configured to accept ACV, ACA, DCV, or DCA input. Both the digital and analog displays can be modified to represent virtually any scaling or engineering units as required. The unit is contained in a 4 1/4" Switchboard housing. It utilizes a taut band moving element and a 0.56", 3 1/2 digit display for indication (+ or - 1999 counts).

#### Electrical Specifications

##### Input Ratings:

**DCV** – Standard inputs are 0-50mV, 100mV 200mV, 10V, 100V, 150V, 300V, 600V, +/-50mV, +/-100mV, +/-200mV, +/-10V, +/-100V, +/-150V, +/-300V, +/-600V Input impedance = 1MΩ

**DCA** – Standard inputs are 0-200uA, 500uA, 1mA, 10mA, 100mA, 500mA, 1A, +/- 200uA, +/-500uA, +/-1mA, +/-10mA, +/-100mA, +/-500mA, +/-1A, 1-5mA, 4-20mA, 10-50mA Voltage Drop < 210mV (inputs < 500mA), < 510mV (inputs < 500mA)

**ACV** – Standard inputs are 0-150V, 250V, 300V, 600V Input impedance = 1MΩ Input Frequencies 45Hz to 65Hz

**ACA** – Standard inputs are 0-1A, 0-5A (Transformer coupled) Input Frequencies 45Hz to 65Hz Other ratings are possible. Contact Yokogawa for special ratings.

**Scaling:** Scaling options are limited only in that there can be no offset zero scaling for the digital display.

##### Overload:

Voltage Inputs: x 1.2 continuous or 700V max;  
x 1.5 for 10 seconds  
DC Current: x 1.2 continuous; x 1.5 for 10 seconds  
AC Current: x 2 continuous; x 5 for 10 seconds

##### Burden:

ACV < 0.5VA @ 600VAC  
ACA < 0.2VA @ 5AAC  
DCV < 0.5W @ 600VDC  
DCA < 0.5W @ 1ADC

##### Isolation Test Voltage:

2KV for 60 seconds aux. power to input, aux. power to case, input to case.

##### Power Supply

**Voltage:** 120V +/-15% standard ; optional 240V +/-15%, 125VDC±15VDC, 24VDC±6VDC, 48VDC±12VDC

**Frequency:** 50/60Hz +/- 2Hz (48Hz to 62Hz) Burden: < 3.5VA



Custom Scale

Standard Scale

#### Display

**Analog:** Taut-band, silicon-damped moving element. 220° Deflection. 6.35" total scale length. White scale with black markings & black pointer (standard). Response time less than 2.5 seconds (0-90%). Optional features include alternate black scale plates, custom logos, colored lines or segments or scale, white or Day-glo orange pointer. Center & Offset zero are available. The Analog display may be scaled to any scaling ratio or to represent any engineering units as required. No external zero regulator. Mechanical zero adjust with special tool. Electrical zero & FS adjust.

**Digital:** 3 1/2 digit, 7 segment display 0.56" (14.2mm) digit height. Red, blue or green LED. Negative Polarity indicator. Selectable decimal point settings. Update rate is 2.5 times/second. Response time less than 1 second (0-90%)

#### Accuracy

Reference conditions 25°C

**Analog:** +/-1% of full scale deflection

**Digital:** AC +/-0.1% of reading +/-3 counts. DC +/- 2 counts

#### Temperature Coefficient:

200ppm/°C of full scale for digital display. Less than 1% additional analog display error over operating temperature range.

**Long Term Stability:** +/-2 counts (digital), +/-0.8% (analog)

**Warm Up time:** 10 minutes

**Cover:** Polycarbonate UL94V0 rated cover and window

**Terminal Plate:** Phenol Resin

**Mounting Studs:** 1/4" x 28 Thread

**Terminal studs:** 10-32 Studs, 0.50" long

**Enclosure Rating:** IP54 (Dust Proof/Splash Proof)

**Weight:** < 2.5 lbs (1134g) including all mounting and connection hardware.

#### Environmental Specifications

**Operating Temperature:** 0°C to 60°C

**Storage Temperature:** -20°C to 70°C

**Humidity:** 90% non-condensing relative humidity @ 40°C

**Isolation Voltage:** 2kV for 1 minute between input and case, input and Aux Power, Aux Power and case

**Vibration:** 8-42Hz, 0.1 to 2 Gs, in 3 axis

**Shock:** 50 G's @ 7 ms for 10 shocks, in 3 axis

**Calibration:** Recommended calibration interval is 2 years.

#### Agency Approvals

**Safety:** UL 61010-1 (AC Auxiliary Power Units Only)  
File #E258096

**Standard model ordering information**

**DC VOLTMETERS AND AMMETERS**  
white scale with black markings + pointer, specify auxiliary power code.

Input	Rating/scale	Red LED Model#	Green LED Model#	Blue LED Model#	
<b>DCV</b>	0-50mV	123011ABAB <input type="checkbox"/>	124011ABAB <input type="checkbox"/>	125011ABAB <input type="checkbox"/>	
	0-100mV	123011AEAE <input type="checkbox"/>	124011AEAE <input type="checkbox"/>	125011AEAE <input type="checkbox"/>	
	0-200mV	123011 AHAH <input type="checkbox"/>	124011 AHAH <input type="checkbox"/>	125011 AHAH <input type="checkbox"/>	
	50-0-50mV	123012 ABAB <input type="checkbox"/>	124012 ABAB <input type="checkbox"/>	125012 ABAB <input type="checkbox"/>	
	100-0-100mV	123012AEAE <input type="checkbox"/>	124012AEAE <input type="checkbox"/>	125012AEAE <input type="checkbox"/>	
	200-0-200mV	123012AHAH <input type="checkbox"/>	124012AHAH <input type="checkbox"/>	125012AHAH <input type="checkbox"/>	
	0-10V	123011MTMT <input type="checkbox"/>	124011MTMT <input type="checkbox"/>	125011MTMT <input type="checkbox"/>	
	0-100V	123011PKPK <input type="checkbox"/>	124011PKPK <input type="checkbox"/>	125011PKPK <input type="checkbox"/>	
	0-150V	123011PZPZ <input type="checkbox"/>	124011PZPZ <input type="checkbox"/>	125011PZPZ <input type="checkbox"/>	
	0-300V	123011RXRX <input type="checkbox"/>	124011RXRX <input type="checkbox"/>	125011RXRX <input type="checkbox"/>	
	0-600V	123011SJSJ <input type="checkbox"/>	124011SJSJ <input type="checkbox"/>	125011SJSJ <input type="checkbox"/>	
	10-0-10V	123012MTMT <input type="checkbox"/>	124012MTMT <input type="checkbox"/>	125012MTMT <input type="checkbox"/>	
	100-0-100V	123012PKPK <input type="checkbox"/>	124012PKPK <input type="checkbox"/>	125012PKPK <input type="checkbox"/>	
	150-0-150V	123012PZPZ <input type="checkbox"/>	124012PZPZ <input type="checkbox"/>	125012PZPZ <input type="checkbox"/>	
	300-0-300V	123012RXRX <input type="checkbox"/>	124012RXRX <input type="checkbox"/>	125012RXRX <input type="checkbox"/>	
	600-0-600V	123012SJSJ <input type="checkbox"/>	124012SJSJ <input type="checkbox"/>	125012SJSJ <input type="checkbox"/>	
	<b>DCA</b>	0-200uA	123111EAEA <input type="checkbox"/>	124111EAEA <input type="checkbox"/>	125111EAEA <input type="checkbox"/>
		0-500uA	123111EMEM <input type="checkbox"/>	124111EMEM <input type="checkbox"/>	125111EMEM <input type="checkbox"/>
200-0-200uA		123112EAEA <input type="checkbox"/>	124112EAEA <input type="checkbox"/>	125112EAEA <input type="checkbox"/>	
500-0-500uA		123112EMEM <input type="checkbox"/>	124112EMEM <input type="checkbox"/>	125112EMEM <input type="checkbox"/>	
0-1mA		123111FAFA <input type="checkbox"/>	124111FAFA <input type="checkbox"/>	125111FAFA <input type="checkbox"/>	
0-10mA		123111GZGZ <input type="checkbox"/>	124111GZGZ <input type="checkbox"/>	125111GZGZ <input type="checkbox"/>	
0-100mA		123111JRJR <input type="checkbox"/>	124111JRJR <input type="checkbox"/>	125111JRJR <input type="checkbox"/>	
0-500mA		123111KMKM <input type="checkbox"/>	124111KMKM <input type="checkbox"/>	125111KMKM <input type="checkbox"/>	
0-1A		123111LALA <input type="checkbox"/>	124111LALA <input type="checkbox"/>	125111LALA <input type="checkbox"/>	
1-0-1mA		123112FAFA <input type="checkbox"/>	124112FAFA <input type="checkbox"/>	125112FAFA <input type="checkbox"/>	
10-0-10mA		123112GZGZ <input type="checkbox"/>	124112GZGZ <input type="checkbox"/>	125112GZGZ <input type="checkbox"/>	
100-0-100mA		123112JRJR <input type="checkbox"/>	124112JRJR <input type="checkbox"/>	125112JRJR <input type="checkbox"/>	
500-0-500mA		123112KMKM <input type="checkbox"/>	124112KMKM <input type="checkbox"/>	125112KMKM <input type="checkbox"/>	
1-0-1A		123112LALA <input type="checkbox"/>	124112LALA <input type="checkbox"/>	125112LALA <input type="checkbox"/>	
1-5mA		123191FYFY <input type="checkbox"/>	124191FYFY <input type="checkbox"/>	125191FYFY <input type="checkbox"/>	
4-20mA		123191HEHE <input type="checkbox"/>	124191HEHE <input type="checkbox"/>	125191HEHE <input type="checkbox"/>	
10-50mA		123191HXHX <input type="checkbox"/>	124191HXHX <input type="checkbox"/>	125191HXHX <input type="checkbox"/>	

**Notes:**

Replace  with the appropriate power supply code: 1=120VAC  
2= 240VAC  
3= 125VDC  
4= 24VDC  
5= 48VDC

1) For non-standard inputs and scales(or aux. power) select the closest rated input model from above and specify per example. "Similar to model 123191HEHE  except..."

**Input signal:** 4-12-20mA dc

**Analog scale:**-1900-0-+1900 Scale color: white, letters + numerals: black, pointer: black

**Analog legend:** DC Amperes

**Digital scale:**+/-1900

**Digital sub-legend:** only required when digital scale is different value from analog.

**Auxiliary power:** 120VAC is standard: 240VAC, 24VDC, 48VDC, and 125VAC are optional.

2) Non-standard models will be assigned a special 3 letter suffix at Yokogawa (ex: 123191HEHE/xxx)



AC VOLTMETERS AND AMMETERS

white scale with black markings and pointer, specify auxiliary power code.

Input	Rating/scale	Red LED Model#	Green LED Model#	Blue LED Model#
ACV	0-150V	123021PZPZ □	124021PZPZ □	125021PZPZ □
	0-250V	123021RSRS □	124021RSRS □	125021RSRS □
	0-300V	123021RXXRX □	124021RXXRX □	125021RXXRX □
	0-600V	123021SJSJ □	124021SJSJ □	125021SJSJ □
Transformer Rated (150V)	0-150V/0-250V	123021PZRS □	124021PZRS □	125021PZRS □
	0-150V/0-300V	123021PZRX □	124021PZRX □	125021PZRX □
	0-150V/0-500V	123021PZSF □	124021PZSF □	125021PZSF □
	0-150V/0-600V	123021PZSJ □	124021PZSJ □	125021PZSJ □
	0-150V/0-750V	123021PZSM □	124021PZSM □	125021PZSM □
	0-150V/0-1500V	123021PZTC □	124021PZTC □	125021PZTC □
	0-150V/0-3.00kV	123021PZVJ □	124021PZVJ □	125021PZVJ □
	0-150V/0-5.00kV	123021PZVT □	124021PZVT □	125021PZVT □
	0-150V/0-5.25kV	123021PZVV □	124021PZVV □	125021PZVV □
	0-150V/0-6.00kV	123021PZVX □	124021PZVX □	125021PZVX □
	0-150V/0-9.00kV	123021PZWJ □	124021PZWJ □	125021PZWJ □
	0-150V/0-15.00kV	123021PZWZ □	124021PZWZ □	125021PZWZ □
	0-150V/0-18.00kV	123021PZXE □	124021PZXE □	125021PZXE □
	0-150V/0-45.0kV	123021PZXU □	124021PZXU □	125021PZXU □
	0-150V/0-150.0kV	123021PZYR □	124021PZYR □	125021PZYR □
	0-150V/0-200kV	123021PZYU □	124021PZYU □	125021PZYU □
0-250V/0-600V	123021RSSJ □	124021RSSJ □	125021RSSJ □	
ACA	0-1A	123131LALA □	124131LALA □	125131LALA □
	0-5A	123131LSLS □	124131LSLS □	125131LSLS □
Transformer Rated (5A)	0-5A/0-10.00A	123131LSMT □	124131LSMT □	125131LSMT □
	0-5A/0-15.00A	123131LSND □	124131LSND □	125131LSND □
	0-5A/0-20.0A	123131LSNG □	124131LSNG □	125131LSNG □
	0-5A/0-25.0A	123131LSNJ □	124131LSNJ □	125131LSNJ □
	0-5A/0-30.0A	123131LSNL □	124131LSNL □	125131LSNL □
	0-5A/0-40.0A	123131LSNP □	124131LSNP □	125131LSNP □
	0-5A/0-50.0A	123131LSNT □	124131LSNT □	125131LSNT □
	0-5A/0-75.0A	123131LSPB □	124131LSPB □	125131LSPB □
	0-5A/0-100.0A	123131LSPK □	124131LSPK □	125131LSPK □
	0-5A/0-150.0A	123131LSPZ □	124131LSPZ □	125131LSPZ □
	0-5A/0-200A	123131LSRL □	124131LSRL □	125131LSRL □
	0-5A/0-250A	123131LSRS □	124131LSRS □	125131LSRS □
	0-5A/0-300A	123131LSRX □	124131LSRX □	125131LSRX □
	0-5A/0-400A	123131LSSC □	124131LSSC □	125131LSSC □
	0-5A/0-500A	123131LSSF □	124131LSSF □	125131LSSF □
	0-5A/0-600A	123131LSSJ □	124131LSSJ □	125131LSSJ □
	0-5A/0-800A	123131LSSN □	124131LSSN □	125131LSSN □
	0-5A/0-1000A	123131LSSS □	124131LSSS □	125131LSSS □
0-5A/0-1200A	123131LSSV □	124131LSSV □	125131LSSV □	
0-5A/0-1500A	123131LSTC □	124131LSTC □	125131LSTC □	

Notes:

Replace □ with the appropriate power supply code: 1=120VAC  
 2= 240VAC  
 3= 125VDC  
 4= 24VDC  
 5= 48VDC

1) For non-standard inputs and scales (or aux. power) select the closest rated input model from above and specify per example. "Similar to model 123131LSLS □ except..."

Input signal: 0 - 5A AC

Analog scale: 0 - 1900, Scale color: white, letters + numerals: black, pointer: black

Analog legend: AC Amperes

Digital scale: 0 - 1900

Digital sub-legend: only required when digital scale is different value from analog.

Auxiliary power: 120VAC is standard; 240VAC, 24VDC, 48VDC and 125VDC are optional.

2) Non-standard models will be assigned a special 3 letter suffix at Yokogawa (ex: 123131LSLS/xxx)

## SWITCHBOARD INSTRUMENTS

### AB/DB17 Switchboard Meters



These internally illuminated meters are used primarily in railway locomotive applications for load and speed indication. They are suited to all applications where scale lighting and high accuracy is required. The wide radius pivot and jewel movement ensures accuracy and stability in the toughest environments. Standard lamps are two LEDs, either red or white

## GENERAL SPECIFICATIONS

### BASIC SPECIFICATION

In accordance with American National Standards Institute Specifications C39.1

### SCALE LENGTH AND ARC

6.9" 250°

#### Scale Type:

White numerals, black platform scale is standard

### NET WEIGHT

Approximately 990 gr. (2.2 lbs)

### OVERSHOOT

Approximately 10%

### ACCURACY

± 1% of full scale D.C. Meters

### RESPONSE TIME

2.5 Seconds Maximum

### METER MECHANISM

Moving coil type pivot and sapphire jewel

### DIELECTRIC LEVEL

4000 Volts A.C. for 1 minute (case to input terminals)

### Outline Dimensions

See page 24

## AB/DB17 MODELS AVAILABLE

Description	Rating and scale	Model type
DC Milliammeter	0-1mA	102117FAZY
DC Millivolts	0-50mV	102121EDZY

**Note:** \*Specify full scale rating, scale color, type, legend, etc.

† Contact factory for minimum / maximum ratings.



**POWER FACTOR SCALE FOR BALANCED SYSTEM**

### Power-Factor Meters

Rating (Amperes)	Rating (L-L Volts)	Scale	AB-40 Cat. No.	AB-16 Cat. No.
<b>Single-Phase/2-Wire, 50/60Hz</b>				
5	120	.5-1-.5	103 412 FCAD	121 412 FCAD
<b>3-Phase 3- &amp; 4-Wire, 50/60Hz Balanced System Only</b>				
5	120	.5-1-.5	103 402 FCAD	121 402 FCAD
5	208	.5-1-.5	103 402 FDAD	—
5	240	.5-1-.5	103 402 FEAD	121 402 FEAD
5	480	.5-1-.5	103 402 FFAD	—
5	600	.5-1-.5	103 402 FGAD	—
<b>3-Phase 3-Wire, 60Hz Unbalanced Systems</b>				
5	120	.5-1-.5	103 462 FCAD	—
5	240	.5-1-.5	103 462 FEAD	—
<b>3-Phase 4-Wire, 60Hz Unbalanced Systems</b>				
5	120	.5-1-.5	103 472 FCAD	—
5	208	.5-1-.5	103 472 FDAD	—
5	416*	.5-1-.5	103 472 FEAD	—
<b>Instruction Book: 4555K35P0701 (For Unbalanced), Outline Dimensions: See page 30</b>				
<b>Instruction Book: 4555K25P0001 (For Balanced), Outline Dimensions: See page 30</b>				

\*240 V L-N



### Frequency Meters, 120V

Scale (Hz)	Center Frequency (Hz)	Accuracy (Hz)	AB-40 Cat. No.	AB-16 Cat. No.
45-55	50	±0.15	103 372 AGAG	121 372 AGAG
45-65	55	±0.25	103 372 AJAJ	121 372 AJAJ
48-52	50	±0.093	103 372 AKAK	121 372 AKAK
50-70	60	±0.25	103 372 ALAL	121 372 ALAL
55-65	60	±0.15	103 372 ANAN	121 372 ANAN
58-62	60	±0.093	103 372 ATAT	121 372 ATAT
59-61	60	±0.047	103 372 ASAS	121 372 ASAS
350-450	400	±1.3	103 372 BHBH	121 372 BHBH
390-410	400	±0.492	103 372 BLBL	121 372 BLBL
<b>Instruction Book: 4555K24P0001, Outline Dimensions: See page 30</b>				



### Synchrosopes — Pivot & Jewel

Scale	Voltage	Normal Frequency	AB-40 Cat. No.	AB-16 Cat. No.
"Slow-Fast"	120	50/60	106 452 ADAA	120 452 ADAA
"Slow-Fast"	120	400	106 452 ACAA	120 452 ACAA
"Slow-Fast"	240	50/60	106 452 DDAA	120 452 DDAA
"Slow-Fast"	240	400	106 452 DCAA	120 452 DCAA
<b>Instruction Book: IM106452-50-60, Outline Dimensions: See page 30</b>				



### Temperature Indicators (Lead Resistance = 0.3 ohms)

Rating (Volts)	Scale	DB-40 Cat. No.	DB-16 Cat. No.
<b>1-Percent of Span for 10-ohm copper RTDs (Resistance Temperature Detectors) 50-600 Hz</b>			
120	20 -140°C	103 502 CAAB†	121 502 CAAB†
120	0-180°F	103 502 CDAD†	121 502 CDAD†
<b>Instruction Book: 4555K12P0001, Outline Dimensions: See page 30</b>			

† Catalog number includes calibrated test resistor

## SWITCHBOARD INSTRUMENTS

### SWITCHBOARD TIME METER

The AB40 switchboard hour meter contains the time-proven 240 elapsed time meter in a 4.33" square weather-resistant case. It is designed for use with other switchboard instruments on electrical switchgear and control panels. It is UL/CSA recognized under file E91703 and meets ANSI C39.1 specifications for shock and vibration. Accuracy of these AC hour meters matches the frequency control of the power system. Models are available with a time range of 0 to 99,999.9 hours in reset and non-reset configurations. The reset model requires the removal of the cover in order to perform the reset function.



Reset Type



Non-Reset Type

### ORDERING SPECIFICATIONS

AB 40 hour meter reset type	AB 40 hour meter Non-reset type	AC voltage rating and frequency
103822AAAB	103811AAAB	120V-60Hz
103822ADAB	103811ADAB	120V-50Hz
103822AGAB	103811AGAB	208V-60Hz
103822AHAB	103811AHAB	208V-50Hz
103822ABAB	103811ABAB	240V-60Hz
103822AEAB	103811AEAB	240V-50Hz
103822ACAB	103811ACAB	480V-60Hz
103822AFAB	103811AFAB	480V-50Hz

### SPECIFICATIONS

**Accuracy:** Matches frequency control of the power system

**Vibration/Shock:** Meets ANSI specification C39.1

**Materials:** Polycarbonate cover and zinc-coated steel case

**Safety:** UL recognized under UL file E91703

**Presentation:** Six digit counter with 5/32" high digits

**Insulation level:** 2000VAC for one minute

**Burden:** Three watts typical

**Motor:** Synchronous

**Dimensions:** Outline dimensions and cutout on page 32



## AC Wattmeters Non-Isolated (cannot be used with external Phase Shifter for Vars)

Rating (Amperes)	Rating (Volts)	Scale	AB-40 Cat. No.	AB-16 Cat. No.
<b>Single-Phase/2-Wire, 1-Element, Transformer-Rated, 50/60 Hz</b>				
5	120	†	103 21 □ A .....	121 21 □ A .....
<b>3-Phase/3-Wire, 2-Element, Transformer-Rated, 50/60Hz ■</b>				
5	120	†	103 22 □ A .....	121 22 □ A .....
5	240	†	103 22 □ C .....	121 22 □ C .....
5	480*	†	103 22 □ D .....	—
5	600*	†	103 22 □ E .....	—
<b>3-Phase/4-Wire, 2½-Element, Transformer-Rated, 50/60Hz, (Voltage balanced) ■</b>				
5	69	†	103 25 □ F	121 25 □ F
5	120	†	103 25 □ A .....	121 25 □ A .....
5	240	†	103 25 □ C .....	121 25 □ C .....
<b>Instruction Book: 4555K26P0701, Outline Dimensions: See page 30</b>				

- † Order by description. Specify CT (Current Transformer) and/or PT (Potential Transformer) ratios if used and scale desired.
- \* UL version in short case, non-UL version in long case.
- Sixth digit signifies pointer deflection (1-zero-left, 2-zero-center).



**Varmeters are usually zero-center and scaled for half the scale values of the accompanying wattmeters. Example: If the Wattmeter is scaled 0-100 Kilowatts, the Varmeter is scaled 50-0-50 Kilovars.**

**NOTE:**

See Application Guide and Tables on the following six pages for selection of commonly used Watt and Var Meters.

## Varmeters (Voltages must be balanced for all polyphase Varmeters)

Rating (Amperes)	Rating (Volts)	Scale	AB-40 Cat. No.	AB-16 Cat. No.
<b>Single-Phase/2-Wire, 1-Element, Transformer Rated, 50/60Hz</b>				
5	120	†	103 31 □ A .....	121 31 □ A .....
5	120	†	103 762 A .....	121 762 A.....*
<b>3-Phase/3-Wire, 2-Element, Transformer-Rated, 50/60Hz (Cannot be used with External Phase Shifter) ■</b>				
5	120	†	103 28 □ A	121 28 □ A....
5	120	†	103 812 A .....	121 812 A....•
<b>3-Phase/3-Wire, 2-Element, Transformer-Rated, 50/60Hz For Use With External Phase Shifters</b>				
5	120	†	103 32 □ A .....	121 32 □ A
5	120	†	103 772 A .....	121 77 2 A*
<b>3-Phase/4-Wire, 2½-Element, Transformer-Rated, 50/60Hz (Cannot be used with External Phase Shifter) ■</b>				
5	208 H	†	103 29 □ B....	121 29 □ B....
5	208 H	†	103 742 B.... s	121 742 B.... s
<b>3-Phase/4-Wire, 2½-Element, Transformer-Rated, 50/60Hz For Use with External Phase Shifters</b>				
5	120	†	103 34 □ A .....	121 34 □ A .....
5	120	†	103 792 A .....	121 792 A .....
<b>Instruction Book: 4555K27P0701, Outline Dimensions: See page30</b>				

- † Order by description. Specify CT (Current Transformer) and/or PT (Potential Transformer) ratios if used and scale desired.
- \* Used for 0-Center when calibrating watts are less than ±380.
- Used for 0-Center when calibrating watts are less than ±658.
- s Used for 0-Center when calibrating watts are less than ±760.
- H The 2½-element varmeters used on 4-wire 3-phase 120V L-N systems are rated 208V because they are connected line-to-line.
- Sixth digit signifies pointer deflection (1-zero left, 2-zero center).



## APPLICATION GUIDE FOR SELECTION OF WATTMETERS AND VARMETERS

**1.** For polyphase applications, see Selector Tables II-V. These tables display complete catalog numbers for use with commonly used combinations of CT and PT ratios. For single phase applications, order by description.

For 3-wire 3-phase wattmeters rated 120 volts, 5A see TABLE II on page 13.

For 3-wire 3-phase varmeters rated 120 volts, 5A see TABLE IV on page 15.

For 4-wire 3-phase wattmeters rated 120 volts, 5A see TABLE III on page 14.

For 4-wire 3-phase varmeters rated 208 volts, 5A see TABLE V on page 16.

**2.** If scale is required to be higher or lower than the pre-selected scale shown in the above tables, see TABLE I on page 12. Choose a scale value between the maximum and minimum shown on this table for the combination of CT and PT ratios. Order by description, giving CT and PT ratios

and choice of scale.

**3.** For transformer ratios and/or ratings not shown in the above tables, see Scale Watts Formula on page 12. This table shows minimum and maximum calibrating watts for various applications and ratings.

Minimum scale = CT ratio x PT ratio x minimum CW x K

Maximum scale = CT ratio x PT ratio x maximum CW x K

Choose a scale between the maximum and minimum. Order by description, giving rating, transformer ratios, and choice of scale.

“PT Ratio x CT Ratio” is sometimes expressed as “TR”.

Example: If CT Ratio is 400/5 and PT Ratio is 480/120; then TR = 320.

**4.** See tables below for scale and legend keys to catalog number (digits 12, 13, 14).

### Key to Watt/Varmeter Scales

This table shows letter combinations assigned to end-scale values to be used for digits 12 & 13 in Catalog number.

Cat. Digit 12, 13	Scale	Cat. Digit 12, 13	Scale	Cat. Digit 12, 13	Scale	Cat. Digit 12, 13	Scale	Cat. Digit 12, 13	Scale
AA	1	BA	10	CA	100	DA	1000	EA	BLANK
AC	1.2	BC	12	CC	120	DC	1200	EC	1.2
AD	1.4	BD	14	CD	140	DD	1400	EE	1.6
AE	1.5	BE	15	CE	150	DE	1500	FC	12.5
AF	1.8	BF	18	CF	180	DF	1800	FD	13
AG	2	BG	20	CG	200	DG	2000	FE	16
AH	2.4	BH	24	CH	240	DH	2400	FG	17.5
AJ	2.5	BJ	25	CJ	250	DJ	2500	FJ	26
AK	3	BK	30	CK	300	DK	3000	GB	115
AL	3.2	BL	32	CL	320	DL	3200	GC	125
AM	3.5	BM	35	CM	350	DM	3500	GD	130
AN	4	BN	40	CN	400	DN	4000	GE	160
AP	4.5	BP	45	CP	450	DP	4500	GG	175
AR	5	BR	50	CR	500	DR	5000	GH	230
AS	5.5	BS	55	CS	550	DS	5500	GJ	260
AT	6	BT	60	CT	600	DT	6000	HC	1250
AU	6.5	BU	65	CU	650	DU	6500	HD	1300
AW	7	BW	70	CW	700	DW	7000	HE	1600
AX	7.5	BX	75	CX	750	DX	7500	HG	1750
AY	8	BY	80	CY	800	DY	8000		
AZ	9	BZ	90	CZ	900	DZ	9000		

### Key to Watt/Varmeter Legends

This table shows letters assigned to inner scale legends to be used for digit 14 in Catalog number.

Digit 14	Wattmeters	Varmeters	Digit 14	Wattmeters	Varmeters	Digit 14	Wattmeters	Varmeters
A	None	None	D	AC Megawatts	Megavars	G	AC MW/Var* <sub>s</sub>	—
B	AC Watts	Vars	E	AC Watts/Vars*	—	T	Percent Horsepower	—
C	AC Kilowatts	Kilovars	F	AC KW/Var* <sub>s</sub>	—	U	Horsepower	—

\*For wattmeters that are to be used with phase shifting transformer for measuring vars.

sStandard Legends AC Kilowatts/Kilovars and AC Megawatts/Megavars

**TABLE I**  
**Selection of Wattmeter Scales**  
 (AB/DB-40/16 have a maximum of 4 digits as standard.)

Scale Selection	CT Primary Current	PT PRIMARY VOLTAGE											
		240	480	600	2400	3600	4200	4800	6000	7200	12000	14400	
Normal Max Min	25	10	20	25	100	150	175	200	250	300	500	600	Kilowatts
		15	30	35	150	200	250	300	350	450	750	900	
		8	16	20	80	120	150	160	200	250	400	500	
Normal Max Min	50	20	40	50	200	300	350	400	500	600	1000	1200	
		30	60	75	300	450	500	600	750	900	1500	1750	
		16	35	40	160	250	300	350	400	500	800	1000	
Normal Max Min	75	30	60	75	300	450	500	600	750	900	1500	1750	
		45	90	100	450	650	750	900	1000	1200	2000	2500	
		25	50	60	250	350	400	500	600	700	1200	1500	
Normal Max Min	100	40	80	100	400	600	700	800	1000	1200	2000	2500	
		60	120	150	600	900	1000	1200	1500	1750	3000	3500	
		35	65	80	350	500	600	650	800	1000	1600	2000	
Normal Max Min	150	60	120	150	600	1000	1000	1200	1500	1750	3000	3500	
		90	175	200	900	1200	1500	1750	2000	2500	4500	5000	
		50	100	100	500	700	800	1000	1200	1500	2500	3000	
Normal Max Min	200	80	150	200	800	1200	1500	1500	2000	2500	4000	5000	
		120	200	300	1200	1750	2000	2000	3000	3500	6000	7000	
		65	125	160	650	1000	1200	1200	1600	2000	3500	4000	
Normal Max Min	300	120	250	300	1200	1750	2000	2500	3000	3500	6000	7500	
		175	350	450	1750	2500	3000	3500	4500	5000	9000	10Mw	
		100	200	250	1000	1500	1600	2000	2500	3000	5000	6000	
Normal Max Min	400	150	300	400	1500	2500	3000	3000	4000	5000	8000	10Mw	
		200	450	600	2000	3500	4000	4500	6000	7000	12Mw	14Mw	
		120	250	350	1200	2000	2500	2500	3500	4000	6500	7500	
Normal Max Min	600	250	500	600	2500	3500	4000	5000	6000	7500	12	15	
		350	700	900	3500	5000	6000	7000	9000	10Mw	17.5	20	
		200	400	500	2000	3000	3500	4000	5000	6000	10	12	
Normal Max Min	800	300	600	800	3000	5000	5000	6000	8000	10Mw	15	20	
		450	900	1200	4500	7000	8000	9000	12Mw	12Mw	20	25	
		250	500	650	2500	4000	4500	5000	6500	7500	15	15	
Normal Max Min	1200	500	1000	1200	5000	7500	8000	10Mw	12	15	25	30	
		700	1200	1750	7000	10Mw	12Mw	12Mw	17.5	20	35	45	
		400	750	1000	4000	6000	6500	7500	10	12	20	25	
Normal Max Min	1500	600	1200	1500	6000	10Mw	10Mw	12	15	17.5	30	35	
		900	1750	2000	9000	12Mw	15Mw	17.5	20	25	45	50	
		500	1000	1000	5000	7000	8000	10	10	15	20	25	
Normal Max Min	2000	800	1500	2000	8000	12	15	15	20	25	40	50	
		1200	2000	3000	12Mw	17.5	20	20	30	35	60	70	
		650	1400	1600	6500	10	12	12	16	20	35	40	
Normal Max Min	3000	1200	2500	3000	12	17.5	20	25	30	35	60	75	
		1750	3500	4500	17.5	25	30	35	45	50	90	100	
		1000	2000	2500	10	15	16	20	25	30	50	60	
Normal Max Min	4000	1500	3000	4000	15	25	30	30	40	50	80	100	
		2000	4500	6000	20	35	40	45	60	70	120	140	
		1200	2500	3500	12	20	25	25	35	40	65	75	

Scale values for 3-wire / 3-phase (120 volts, 5 ampere) For 4-wire / 3-phase multiply by 2. For single-phase divide by 2. **Note:** PT Primary Voltages shown are the line to neutral value for 3-phase / 4-wire circuits.

**Scale Watts Formula:**

The limits of full-scale values depend upon the rating of the instrument and the current and potential transformer ratios used. In order to determine whether the desired full-scale value is within limits, the following calibrating-watts formula and table are used. If the calibrating watts value falls within the range shown in the table for the instrument rating, the scale is acceptable.

$$\text{Calibrating Watts/Element} = \frac{\text{Desired full-scale value in watts or vars}}{\text{CW}} = \frac{\text{Desired full-scale value in watts or vars}}{(\text{PT Ratio}) \times (\text{CT Ratio}) \times K}$$

Where K = 1 for 1-phase/2-wire circuits  
 K = 2 for 1-phase/3-wire, 2-phase/3-wire, 2-phase/4-wire, 3 phase/3-wire circuits  
 K = 4 for 3-phase/4-wire circuits  
 Except K = 1.1547 for var models (10328 — & 103812 — 10329 — & 103742 — cross phase only)

STANDARD CALIBRATING WATT RANGES FOR 5A 120V RATING

Model	Zero Left or Center*	Zero Center * s Low Cal Watts
Watt or Var (except below)	380 — 760	190 — 760
2 el. Var 10328 — & 103812 —	658 — 1316	329 — 1316
2½ el. Var 10329 — & 103742 —	760 — 1520	380 — 1520

\* Other Voltage & current ratings will be proportional  
 s End scale values  
 Note 1: For 10329 and 103742 (2½ element varmeters only) Catalog Number Digits 8, 9, 10 are one-half (½) the CW (∴ calibration current) as calculated using K = 1.1547  
 Note 2: The constant K may differ for various "short-cut" methods of metering watts or vars.

TABLE II

**Wattmeter Selector**

For 3-Wire 3-Phase (2-element) Wattmeter 5A 120V (Zero-Left)

AB-40 Cat. No. 103221A..... Find Digits 8-14 & scale at  
 AB-16 Cat. No. 121221A..... Intersection of C.T. & P.T. Ratios  
 (For zero center change Digit 6 from 1 to 2)

C.T. RATIO ↓	P.T. RATIO															
	2400/120 (2:1)	480/120 (4:1)	600/120 (5:1)	2400/120 (20:1)	3600/120 (30:1)	4200/120 (35:1)	4800/120 (40:1)	6000/120 (50:1)	7200/120 (60:1)	12000/120 (100:1)	14400/120 (120:1)					
25/5 (5:1)	RBU7BAC 10KW	RBU7BGC 20KW	RBU7BJC 25KW	RBU7CAC 100KW	RBU7CEC 150KW	RBU7GGC 175KW	RBU7CGC 200KW	RBU7CJC 250KW	RBU7CKC 300KW	RBU7CRC 500KW	RBU7CKC 300KW	RBU7CRC 500KW	RBU7CKC 300KW	RBU7CRC 500KW	RBU7CTC 600KW	RBU7DCC 1200KW
50/5 (10:1)	RBU7BGC 20KW	RBU7BNC 40KW	RBU7BRC 50KW	RBU7CGC 200KW	RBU7CKC 300KW	RBU7CMC 350KW	RBU7CNC 400KW	RBU7CJC 500KW	RBU7CTC 600KW	RBU7CXC 750KW	RBU7DCC 1200KW	RBU7DGC 1500KW	RBU7DCC 1200KW	RBU7DGC 1500KW	RBU7DCC 1200KW	RBU7DCC 1200KW
75/5 (15:1)	RBU7BKC 30KW	RBU7BTC 60KW	RBU7BXC 75KW	RBU7CKC 300KW	RBU7CPC 450KW	XGJ7CRC 500KW	RBU7CWC 700KW	RBU7CTC 600KW	RBU7CXC 750KW	RBU7DCC 1200KW	RBU7DGC 1500KW	RBU7DCC 1200KW	RBU7DGC 1500KW	RBU7DCC 1200KW	RBU7DGC 1500KW	RBU7DCC 1200KW
100/5 (20:1)	RBU7BNC 40KW	RBU7BYC 80KW	RBU7CAC 100KW	RBU7CNC 400KW	RBU7CTC 600KW	RBU7DCC 1200KW	RBU7DGC 1500KW	RBU7DCC 1200KW	RBU7DGC 1500KW	RBU7DCC 1200KW	RBU7DGC 1500KW	RBU7DCC 1200KW	RBU7DGC 1500KW	RBU7DCC 1200KW	RBU7DGC 1500KW	RBU7DCC 1200KW
150/5 (30:1)	RBU7BTC 60KW	RBU7CCC 120KW	RBU7CEC 150KW	RBU7CTC 600KW	RBU7CZC 900KW	XGJ7DAC 1000KW	RBU7DCC 1200KW	RBU7DGC 1500KW	RBU7DCC 1200KW	RBU7DGC 1500KW	RBU7DCC 1200KW	RBU7DGC 1500KW	RBU7DCC 1200KW	RBU7DGC 1500KW	RBU7DCC 1200KW	RBU7DCC 1200KW
200/5 (40:1)	RBU7BYC 80KW	RBU7GEC 160KW	RBU7CGC 200KW	RBU7CYC 800KW	RBU7DCC 1200KW	RBU7DDC 1400KW	RBU7HEC 1600KW	RBU7DCC 1200KW	RBU7DGC 1500KW	RBU7DCC 1200KW	RBU7DGC 1500KW	RBU7DCC 1200KW	RBU7DGC 1500KW	RBU7DCC 1200KW	RBU7DGC 1500KW	RBU7DCC 1200KW
250/5 (50:1)	RBU7CAC 100KW	RBU7CGC 200KW	RBU7CJC 250KW	RBU7DAC 1000KW	RBU7DEC 1500KW	RBU7HGC 1750KW	RBU7DCC 1200KW	RBU7DGC 1500KW	RBU7DCC 1200KW	RBU7DGC 1500KW	RBU7DCC 1200KW	RBU7DGC 1500KW	RBU7DCC 1200KW	RBU7DGC 1500KW	RBU7DCC 1200KW	RBU7DCC 1200KW
300/5 (60:1)	RBU7CCC 120KW	RBU7CHC 240KW	RBU7CKC 300KW	RBU7DCC 1200KW	RBU7DFC 1800KW	XGJ7DGC 2000KW	RBU7DHC 2400KW	RBU7DCC 1200KW	RBU7DGC 1500KW	RBU7DCC 1200KW	RBU7DGC 1500KW	RBU7DCC 1200KW	RBU7DGC 1500KW	RBU7DCC 1200KW	RBU7DGC 1500KW	RBU7DCC 1200KW
400/5 (80:1)	RBU7GEC 160KW	RBU7CLC 320KW	RBU7CNC 400KW	RBU7HEC 1600KW	RBU7DHC 2400KW	RET7DKC 3000KW	RBU7DLC 3200KW	RBU7DCC 1200KW	RBU7DGC 1500KW	RBU7DCC 1200KW	RBU7DGC 1500KW	RBU7DCC 1200KW	RBU7DGC 1500KW	RBU7DCC 1200KW	RBU7DGC 1500KW	RBU7DCC 1200KW
500/5 (100:1)	RBU7CGC 200KW	RBU7CNC 400KW	RBU7CRC 500KW	RBU7DGC 2000KW	RBU7DKC 3000KW	RBU7DMC 3500KW	RBU7DNC 4000KW	RBU7DCC 1200KW	RBU7DGC 1500KW	RBU7DCC 1200KW	RBU7DGC 1500KW	RBU7DCC 1200KW	RBU7DGC 1500KW	RBU7DCC 1200KW	RBU7DGC 1500KW	RBU7DCC 1200KW
600/5 (120:1)	RBU7CHC 240KW	RDR7CRC 500KW	RBU7CTC 600KW	RBU7DHC 2400KW	RA57DMC 3500KW	XGJ7DNC 4000KW	RDR7DRC 5000KW	RBU7DCC 1200KW	RBU7DGC 1500KW	RBU7DCC 1200KW	RBU7DGC 1500KW	RBU7DCC 1200KW	RBU7DGC 1500KW	RBU7DCC 1200KW	RBU7DGC 1500KW	RBU7DCC 1200KW
800/5 (160:1)	RBU7CLC 320KW	XAG7CTC 600KW	RBU7CYC 800KW	RBU7DLC 3200KW	RDR7DRC 5000KW	RET7DTC 6000KW	XAG7DTC 6000KW	RBU7DCC 1200KW	RBU7DGC 1500KW	RBU7DCC 1200KW	RBU7DGC 1500KW	RBU7DCC 1200KW	RBU7DGC 1500KW	RBU7DCC 1200KW	RBU7DGC 1500KW	RBU7DCC 1200KW
1000/5 (200:1)	RBU7CNC 400KW	RBU7CYC 800KW	RBU7DAC 1000KW	RBU7DNC 4000KW	RBU7DTC 6000KW	RBU7DWC 7000KW	RBU7DCC 1200KW	RBU7DGC 1500KW	RBU7DCC 1200KW	RBU7DGC 1500KW	RBU7DCC 1200KW	RBU7DGC 1500KW	RBU7DCC 1200KW	RBU7DGC 1500KW	RBU7DCC 1200KW	RBU7DCC 1200KW
1200/5 (240:1)	RDR7CRC 500KW	RDR7DAC 1000KW	RBU7DCC 1200KW	RDR7DRC 5000KW	RA57DWC 7000KW	XGJ7DYC 8000KW	RDR7BAD 10KW	RBU7DCC 1200KW	RBU7DGC 1500KW	RBU7DCC 1200KW	RBU7DGC 1500KW	RBU7DCC 1200KW	RBU7DGC 1500KW	RBU7DCC 1200KW	RBU7DGC 1500KW	RBU7DCC 1200KW
1500/5 (300:1)	RBU7CTC 600KW	RBU7DCC 1200KW	RBU7DEC 1500KW	RBU7DTC 6000KW	RBU7DZC 9000KW	XGJ7BAD 10MW	RBU7BCD 12MW	RBU7BDC 15MW	RBU7BFD 18MW	RBU7BDC 15MW	RBU7BFD 18MW	RBU7BDC 15MW	RBU7BFD 18MW	RBU7BDC 15MW	RBU7BFD 18MW	RBU7BDC 15MW
2000/5 (400:1)	RBU7CYC 800KW	RBU7HEC 1600KW	RBU7DGC 2000KW	RBU7DYC 8000KW	RBU7BDC 12MW	RBU7BDD 14MW	RBU7FED 16MW	RBU7BGD 20MW	RBU7BHD 24MW	RBU7BGD 20MW	RBU7BHD 24MW	RBU7BGD 20MW	RBU7BHD 24MW	RBU7BGD 20MW	RBU7BHD 24MW	RBU7BGD 20MW
2500/5 (500:1)	RBU7DAC 1000KW	RBU7DGC 2000KW	RBU7DJC 2500KW	RBU7BAD 10MW	RBU7BED 15MW	RBU7FGD 17.5MW	RBU7BGD 20MW	RBU7BJD 25MW	RBU7BKD 30MW	RBU7BGD 20MW	RBU7BKD 30MW	RBU7BGD 20MW	RBU7BKD 30MW	RBU7BGD 20MW	RBU7BKD 30MW	RBU7BGD 20MW
3000/5 (600:1)	RBU7DCC 1200KW	RBU7DHC 2400KW	RBU7DKC 3000KW	RBU7BCD 12MW	RBU7BFD 18MW	XGJ7BGD 20MW	RBU7BHD 24MW	RBU7BKD 30MW	RBU7BMD 35MW	RBU7BHD 24MW	RBU7BMD 35MW	RBU7BHD 24MW	RBU7BMD 35MW	RBU7BHD 24MW	RBU7BMD 35MW	RBU7BHD 24MW
4000/5 (800:1)	RBU7HEC 1600KW	RBU7DLC 3200KW	RBU7DNC 4000KW	RBU7FED 16MW	RBU7BHD 24MW	RET7BKD 30MW	RBU7BLD 32MW	RBU7BND 40MW	RDR7BRD 50MW	RBU7BYD 80MW	RDR7CAD 100MW	RBU7BYD 80MW	RDR7CAD 100MW	RBU7BYD 80MW	RDR7CAD 100MW	RBU7BYD 80MW
5000/5 (1000:1)	RBU7DGC 2000KW	RBU7DNC 4000KW	RBU7DRC 5000KW	RBU7BGD 20MW	RBU7BKD 30MW	RBU7BMD 35MW	RBU7BND 40MW	RBU7BRD 50MW	RBU7BTD 60MW	RBU7CAD 100MW	RBU7CCD 120MW	RBU7BRD 50MW	RBU7BTD 60MW	RBU7CAD 100MW	RBU7CCD 120MW	RBU7BRD 50MW



TABLE III

**Wattmeter Selector**

For 4-Wire 3-Phase (2½-element) Wattmeter 5A 120V (Zero-Left)

AB-40 Cat. No. 103251A..... Find Digits 8-14 & scale at  
 AB-16 Cat. No. 121251A..... Intersection of C.T. & P.T. Ratios  
 (For zero center change Digit 6 from 1 to 2)

C.T. RATIO ↓	P.T. RATIO										
	240/120 (2:1)	480/120 (4:1)	600/120 (5:1)	2400/120 (20:1)	3600/120 (30:1)	4200/120 (35:1)	4800/120 (40:1)	6000/120 (50:1)	7200/120 (60:1)	12000/120 (100:1)	14400/120 (120:1)
25/5 (5:1)	RBU7BGC 20KW	RBU7BNC 40KW	RBU7BRC 50KW	RBU7GCG 200KW	RBU7CKC 300KW	RBU7CMC 350KW	RBU7CNC 400KW	RBU7CRC 500KW	RBU7CTC 600KW	RBU7DAC 1000KW	RBU7DCC 1200KW
50/5 (10:1)	RBU7BNC 40KW	RBU7BYC 80KW	RBU7CAC 100KW	RBU7CNC 400KW	RBU7CTC 600KW	RBU7CWC 700KW	RBU7CYC 800KW	RBU7DAC 1000KW	RBU7DCC 1200KW	RBU7DGC 2000KW	RBU7DHC 2400KW
75/5 (15:1)	RBU7BTC 60KW	RBU7CCC 120KW	RBU7CEC 150KW	RBU7CTC 600KW	RBU7CZC 900KW	XGJ7DAC 1000KW	RBU7DCC 1200KW	RBU7DEC 1500KW	RBU7DFC 1800KW	RBU7DKC 3000KW	RBU7DMC 3500KW
100/5 (20:1)	RBU7BYC 80KW	RBU7GEC 160KW	RBU7GCG 200KW	RBU7CYC 800KW	RBU7DCC 1200KW	RBU7DDC 1400KW	RBU7HEC 1600KW	RBU7DGC 2000KW	RBU7DHC 2400KW	RBU7DNC 4000KW	RBU7DPC 4500KW
150/5 (30:1)	RBU7CCC 120KW	RBU7CHC 240KW	RBU7CKC 300KW	RBU7DCC 1200KW	RBU7DFC 1800KW	XGJ7DGC 2000KW	RBU7DHC 2400KW	RBU7DKC 3000KW	RA57DMC 3500KW	RBU7DTC 6000KW	RA57DWC 7000KW
200/5 (40:1)	RBU7GEC 160KW	RBU7CLC 320KW	RBU7CNC 400KW	RBU7HEC 1600KW	RBU7DHC 2400KW	UCA7DJC 2500KW	RBU7DLC 3200KW	RBU7DNC 4000KW	XAG7DPC 4500KW	RBU7DYC 8000KW	XAG7DZC 9000KW
250/5 (50:1)	RBU7GCG 200KW	RBU7CNC 400KW	RBU7CRC 500KW	RBU7DGC 2000KW	RBU7DKC 3000KW	RBU7DMC 3500KW	RBU7DNC 4000KW	RBU7DRC 5000KW	RBU7DTC 6000KW	RBU7BAD 10MW	RBU7BCD 12MW
300/5 (60:1)	RBU7CHC 240KW	XAG7CPC 450KW	RBU7CTC 600KW	RBU7DHC 2400KW	RA57DMC 3500KW	XGJ7DNC 4000KW	XAG7DPC 4500KW	RBU7DTC 6000KW	RA57DWC 7000KW	RBU7BCD 12MW	RA57BDD 14MW
400/5 (80:1)	RBU7CLC 320KW	XAG7CTC 600KW	RBU7CYC 800KW	RBU7DLC 3200KW	XAG7DPC 4500KW	UCA7DRC 5000KW	XAG7DTC 6000KW	RBU7DYC 8000KW	XAG7DZC 9000KW	RBU7FED 16MW	XAG7BFD 18MW
500/5 (100:1)	RBU7CNC 400KW	RBU7CYC 800KW	RBU7DAC 1000KW	RBU7DNC 4000KW	RBU7DTC 6000KW	RBU7DWC 7000KW	RBU7DYC 8000KW	RBU7BAD 10MW	RBU7BCD 12MW	RBU7BGD 20MW	RBU7BHD 24MW
600/5 (120:1)	XAG7CPC 450KW	XAG7CZC 900KW	RBU7DCC 1200KW	XAG7DPC 4500KW	RA57DWC 7000KW	XGJ7DYC 8000KW	XAG7DZC 9000KW	RBU7BCD 12MW	RA57BDD 14MW	RBU7BHD 24MW	TBH7BJD 25MW
800/5 (160:1)	XAG7CTC 600KW	XAG7DCC 1200KW	RBU7HEC 1600KW	XAG7DTC 6000KW	XAG7DZC 9000KW	UCA7BAD 10MW	XAG7BCD 12MW	RBU7FED 16MW	XAG7BFD 18MW	RBU7BLD 32MW	UKJ7BMD 35MW
1000/5 (200:1)	RBU7CYC 800KW	RBU7HEC 1600KW	RBU7DGC 2000KW	RBU7DYC 8000KW	RBU7BCD 12MW	RBU7BDD 14MW	RBU7FED 16MW	RBU7BGD 20MW	RBU7BHD 24MW	RBU7BND 40MW	XAG7BPD 45MW
1200/5 (240:1)	XAG7CZC 900KW	XAG7DFC 1800KW	RBU7DHC 2400KW	XAG7DZC 9000KW	RA57BDD 14MW	XGJ7FED 16MW	XAG7BFD 18MW	RBU7BHD 24MW	TBH7BJD 25MW	XAG7BPD 45MW	TBH7BRD 50MW
1500/5 (300:1)	RBU7DCC 1200KW	RBU7DHC 2400KW	RBU7DKC 3000KW	RBU7BCD 12MW	RBU7BFD 18MW	XGJ7BGD 20MW	RBU7BHD 24MW	RBU7BKD 30MW	RA57BMD 35MW	RBU7BTD 60MW	RA57BWD 70MW
2000/5 (400:1)	RBU7HEC 1600KW	RBU7DLC 3200KW	RBU7DNC 4000KW	RBU7FED 16MW	RBU7BHD 24MW	UCA7BJD 25MW	RBU7BLD 32MW	RBU7BND 40MW	XAG7BPD 45MW	RBU7BYD 80MW	XAG7BZD 90MW
2500/5 (500:1)	RBU7DGC 2000KW	RBU7DNC 4000KW	RBU7DRC 5000KW	RBU7BGD 20MW	RBU7BKD 30MW	RBU7BMD 35MW	RBU7BND 40MW	RBU7BRD 50MW	RBU7BTD 60MW	RBU7CAD 100MW	RBU7CCD 120MW
3000/5 (600:1)	RBU7DHC 2400KW	XAG7DPC 4500KW	RBU7DTC 6000KW	RBU7BHD 24MW	RA57BMD 35MW	XGJ7BND 40MW	XAG7BPD 45MW	RBU7BTD 60MW	RA57BWD 70MW	RBU7CCD 120MW	RA57CDD 140MW
4000/5 (800:1)	RBU7DLC 3200KW	XAG7DTC 6000KW	RBU7DYC 8000KW	RBU7BLD 32MW	XAG7BPD 45MW	UCA7BRD 50MW	XAG7BTD 60MW	RBU7BYD 80MW	XAG7BZD 90MW	RBU7GED 160MW	XAG7CFD 180MW
5000/5 (1000:1)	RBU7DNC 4000KW	RBU7DYC 8000KW	RBU7BAD 10MW	RBU7BND 40MW	RBU7BTD 60MW	RBU7BWD 70MW	RBU7BYD 80MW	RBU7CAD 100MW	RBU7CCD 120MW	RBU7CGD 200MW	RBU7CHD 240MW

**TABLE IV**

**Varmeter Selector**

For 3-Wire 3-Phase (2-element) Varmeter rated 5A 120V (Zero-Center)

AB-40 Cat. No. 103812A..... Find Digits 8-14 & scale at  
 AB-16 Cat. No. 121812A..... Intersection of C.T. & P.T. Ratios

C.T. RATIO ↓	P.T. RATIO										
	2400/120 (2:1)	480/120 (4:1)	600/120 (5:1)	2400/120 (20:1)	3600/120 (30:1)	4200/120 (35:1)	4800/120 (40:1)	6000/120 (50:1)	7200/120 (60:1)	12000/120 (100:1)	14400/120 (120:1)
25/5 (5:1)	TAJ7ARC 5KVAR	TAJ7BAC 10KVAR	TAJ7FCC 12.5KVAR	TAJ7BRC 50KVAR	TAJ7BXC 75KVAR	NK7BYC 80KVAR	TAJ7CAC 100KVAR	TAJ7GCC 125KVAR	TAJ7CEC 150KVAR	TAJ7CJC 250KVAR	TAJ7CKC 300KVAR
50/5 (10:1)	TAJ7BAC 10KVAR	TAJ7BGC 20KVAR	TAJ7BIC 25KVAR	TAJ7CAC 100KVAR	TAJ7CEC 150KVAR	TAJ7GGC 175KVAR	TAJ7CGC 200KVAR	TAJ7JIC 250KVAR	TAJ7CKC 300KVAR	TAJ7CRC 500KVAR	TAJ7CTC 600KVAR
75/5 (15:1)	TAJ7BEC 15KVAR	TAJ7BKC 30KVAR	WEK7BNC 40KVAR	TAJ7CEC 150KVAR	WEK7GHC 240KVAR	RDH7CJC 250KVAR	TAJ7CKC 300KVAR	WEK7CNC 400KVAR	TAJ7GPC 450KVAR	TAJ7CXC 750KVAR	TAJ7CZC 900KVAR
100/5 (20:1)	TAJ7BGC 20KVAR	TAJ7BNC 40KVAR	TAJ7BRC 50KVAR	TAJ7CGC 200KVAR	TAJ7CKC 300KVAR	TAJ7CMC 350KVAR	TAJ7CNC 400KVAR	TAJ7CRC 500KVAR	TAJ7CTC 600KVAR	TAJ7DAC 1000KVAR	TAJ7DCC 1200KVAR
150/5 (30:1)	TAJ7BKC 30KVAR	TAJ7BTC 60KVAR	TAJ7BXC 75KVAR	TAJ7CKC 300KVAR	TAJ7GPC 450KVAR	RDH7CRC 500KVAR	TAJ7CTC 600KVAR	TAJ7CXC 750KVAR	TAJ7CZC 900KVAR	TAJ7DEC 1500KVAR	TAJ7HGC 1750KVAR
200/5 (40:1)	TAJ7BNC 40KVAR	TAJ7BYC 80KVAR	TAJ7CAC 100KVAR	TAJ7CNC 400KVAR	TAJ7CTC 600KVAR	TAJ7CWC 700KVAR	TAJ7CYC 800KVAR	TAJ7DAC 1000KVAR	TAJ7DCC 1200KVAR	TAJ7DGC 2000KVAR	UFJ7DJC 2500KVAR
250/5 (50:1)	TAJ7BRC 50KVAR	TAJ7CAC 100KVAR	TAJ7GCC 125KVAR	TAJ7CRC 500KVAR	TAJ7CXC 750KVAR	NK7CYC 800KVAR	TAJ7DAC 1000KVAR	TAJ7HCC 1250KVAR	TAJ7DED 1500KVAR	TAJ7DJC 2500KVAR	TAJ7DKC 3000KVAR
300/5 (60:1)	TAJ7BTC 60KVAR	TAJ7CCC 120KVAR	TAJ7CEC 150KVAR	TAJ7CTC 600KVAR	TAJ7CZC 900KVAR	RDH7DAC 1000KVAR	TAJ7DCC 1200KVAR	TAJ7DEC 1500KVAR	SAJ7HGC 1750KVAR	TAJ7DKC 3000KVAR	SAJ7DMC 3500KVAR
400/5 (80:1)	TAJ7BYC 80KVAR	TAJ7GEC 160KVAR	TAJ7CGC 200KVAR	TAJ7CYC 800KVAR	TAJ7DCC 1200KVAR	WGG7DEC 1500KVAR	TAJ7HEC 1600KVAR	TAJ7DGC 2000KVAR	UFJ7DJC 2500KVAR	TAJ7DNC 4000KVAR	UFJ7ARD 5MVAR
500/5 (100:1)	TAJ7CAC 100KVAR	TAJ7CGC 200KVAR	TAJ7CIC 250KVAR	TAJ7DAC 1000KVAR	TAJ7DEC 1500KVAR	TAJ7HGC 1750KVAR	TAJ7DGC 2000KVAR	TAJ7DJC 2500KVAR	TAJ7DKC 3000KVAR	TAJ7ARD 5MVAR	TAJ7ATD 6MVAR
600/5 (120:1)	TAJ7CCC 120KVAR	UFJ7CIC 250KVAR	TAJ7CKC 300KVAR	TAJ7DCC 1200KVAR	SAJ7HGC 1750KVAR	RDH7DGC 2000KVAR	TAJ7DHC 2400KVAR	TAJ7DKC 3000KVAR	SAJ7DMC 3500KVAR	TAJ7ATD 6MVAR	UFJ7AXD 7.5MVAR
800/5 (160:1)	TAJ7GEC 160KVAR	PIB7CKC 300KVAR	TAJ7CNC 400KVAR	TAJ7HEC 1600KVAR	UFJ7DJC 2500KVAR	WGG7DKC 3000KVAR	PIB7DKC 3000KVAR	TAJ7DNC 4000KVAR	UFJ7ARD 5MVAR	TAJ7AYD 8MVAR	UFJ7BAD 10MVAR
1000/5 (200:1)	TAJ7CGC 200KVAR	TAJ7CNC 400KVAR	TAJ7CRC 500KVAR	TAJ7DGC 2000KVAR	TAJ7DKC 3000KVAR	TAJ7DMC 3500KVAR	TAJ7DNC 4000KVAR	TAJ7ARD 5MVAR	TAJ7ATD 6MVAR	TAJ7BAD 10MVAR	TAJ7BCD 12MVAR
1200/5 (240:1)	UFJ7CIC 250KVAR	UFJ7CRC 500KVAR	TAJ7CTC 600KVAR	UFJ7DJC 2500KVAR	SAJ7DMC 3500KVAR	RDH7DNC 4000KVAR	UFJ7ARD 5MVAR	TAJ7ATD 6MVAR	UFJ7AXD 7.5MVAR	TAJ7BCD 12MVAR	UFJ7BED 15MVAR
1500/5 (300:1)	TAJ7CKC 300KVAR	TAJ7CTC 600KVAR	TAJ7CXC 750KVAR	TAJ7DKC 3000KVAR	TAJ7DPC 4500KVAR	RDH7ARD 5MVAR	TAJ7ATD 6MVAR	TAJ7AXD 7.5MVAR	TAJ7AZD 9MVAR	TAJ7BED 15MVAR	SAJ7FGD 17.5MVAR
2000/5 (400:1)	TAJ7CNC 400KVAR	TAJ7CYC 800KVAR	TAJ7DAC 1000KVAR	TAJ7DNC 4000KVAR	TAJ7ATD 6MVAR	TAJ7AWD 7MVAR	TAJ7AYD 8MVAR	TAJ7BAD 10MVAR	TAJ7BCD 12MVAR	TAJ7BGD 20MVAR	UFJ7BJD 25MVAR
2500/5 (500:1)	TAJ7CRC 500KVAR	TAJ7DAC 1000KVAR	TAJ7HCC 1250KVAR	TAJ7ARD 5MVAR	TAJ7AXD 7.5MVAR	NK7AYD 8MVAR	TAJ7BAD 10MVAR	TAJ7FCD 12.5MVAR	TAJ7BED 15MVAR	TAJ7BJD 25MVAR	TAJ7BKD 30MVAR
3000/5 (600:1)	TAJ7CTC 600KVAR	TAJ7DCC 1200KVAR	TAJ7DEC 1500KVAR	TAJ7ATD 6MVAR	TAJ7AZD 9MVAR	RDH7BAD 10MVAR	TAJ7BCD 12MVAR	TAJ7BED 15MVAR	SAJ7FGD 17.5MVAR	TAJ7BKD 30MVAR	SAJ7BMD 35MVAR
4000/5 (800:1)	TAJ7CYC 800KVAR	TAJ7HEC 1600KVAR	TAJ7DGC 2000KVAR	TAJ7AYD 8MVAR	TAJ7BCD 12MVAR	WGG7BED 15MVAR	TAJ7FED 16MVAR	TAJ7BGD 20MVAR	UFJ7BJD 25MVAR	TAJ7BND 40MVAR	UFJ7BRD 50MVAR
5000/5 (1000:1)	TAJ7DAC 1000KVAR	TAJ7DGC 2000KVAR	TAJ7DJC 2500KVAR	TAJ7BAD 10MVAR	TAJ7BED 15MVAR	TAJ7FGD 17.5MVAR	TAJ7BGD 20MVAR	TAJ7BJD 25MVAR	TAJ7BKD 30MVAR	TAJ7BRD 50MVAR	TAJ7BTD 60MVAR

**TABLE V**

**Varmeter Selector (See Notes, Page 3)**

For 4-Wire 3-Phase (2½-element) Varmeter rated 5A 208V (Zero-Center)

AB-40 Cat. No. 103742B..... Find Digits 8-14, & scale at  
 AB-16 Cat. No. 121742B..... Intersection of C.T. & P.T. Ratios

C.T. RATIO ↓	P.T. RATIO										
	240/120 (2:1)	480/120 (4:1)	600/120 (5:1)	2400/120 (20:1)	3600/120 (30:1)	4200/120 (35:1)	4800/120 (40:1)	6000/120 (50:1)	7200/120 (60:1)	12000/120 (100:1)	14400/120 (120:1)
25/5 (5:1)	AWP7BAC 10KVAR	AWP7BGC 20KVAR	AWP7BJC 25KVAR	AWP7CAC 100KVAR	AWP7CEC 150KVAR	AWP7GGC 175KVAR	AWP7GCG 200KVAR	AWP7CJC 250KVAR	AWP7CKC 300KVAR	AWP7CRC 500KVAR	AWP7CTC 600KVAR
50/5 (10:1)	AWP7BGC 20KVAR	AWP7BNC 40KVAR	AWP7BRC 50KVAR	AWP7CGC 200KVAR	AWP7CKC 300KVAR	AWP7CMC 350KVAR	AWP7CNC 400KVAR	AWP7CRC 500KVAR	AWP7CTC 600KVAR	AWP7DAC 1000KVAR	AWP7DCC 1200KVAR
75/5 (15:1)	AWP7BKC 30KVAR	AWP7BTC 60KVAR	AWP7BXC 75KVAR	AWP7CKC 300KVAR	AWP7PC 450KVAR	KWE7CRC 500KVAR	AWP7CTC 600KVAR	AWP7CXC 750KVAR	AWP7CZC 900KVAR	AWP7DEC 1500KVAR	AWP7DFC 1800KVAR
100/5 (20:1)	AWP7BNC 40KVAR	AWP7BYC 80KVAR	AWP7CAC 100KVAR	AWP7CNC 400KVAR	AWP7CTC 600KVAR	AWP7CWC 700KVAR	AWP7CYC 800KVAR	AWP7DAC 1000KVAR	AWP7DCC 1200KVAR	AWP7DGC 2000KVAR	AWP7DHC 2400KVAR
150/5 (30:1)	AWP7BTC 60KVAR	AWP7CCC 120KVAR	AWP7CEC 150KVAR	AWP7CTC 600KVAR	AWP7CZC 900KVAR	KWE7DAC 1000KVAR	AWP7DCC 1200KVAR	AWP7DEC 1500KVAR	AWP7DFC 1800KVAR	AWP7DKC 3000KVAR	AWP7DMC 3500KVAR
200/5 (40:1)	AWP7BYC 80KVAR	AWP7GEC 160KVAR	AWP7CGC 200KVAR	AWP7CYC 800KVAR	AWP7DCC 1200KVAR	AWP7DDC 1400KVAR	AWP7HEC 1600KVAR	AWP7DGC 2000KVAR	AWP7DHC 2400KVAR	AWP7DNC 4000KVAR	KSC7DPC 4500KVAR
250/5 (50:1)	AWP7CAC 100KVAR	AWP7CGC 200KVAR	AWP7CJC 250KVAR	AWP7DAC 1000KVAR	AWP7DEC 1500KVAR	AWP7HCC 1750KVAR	AWP7DGC 2000KVAR	AWP7DJC 2500KVAR	AWP7DKC 3000KVAR	AWP7DRC 5000KVAR	AWP7DTC 6000KVAR
300/5 (60:1)	AWP7CCC 120KVAR	AWP7CHC 240KVAR	AWP7CKC 300KVAR	AWP7DCC 1200KVAR	AWP7DFC 1800KVAR	KWE7DGC 2000KVAR	AWP7DHC 2400KVAR	AWP7DKC 3000KVAR	AWP7DMC 3500KVAR	AWP7DTC 6000KVAR	AWP7DWC 7000KVAR
400/5 (80:1)	AWP7GEC 160KVAR	AWP7CLC 320KVAR	AWP7CNC 400KVAR	AWP7HEC 1600KVAR	AWP7DHC 2400KVAR	JTA7DJC 2500KVAR	AWP7DLC 3200KVAR	AWP7DNC 4000KVAR	KSC7DPC 4500KVAR	AWP7DYC 8000KVAR	KSC7DZC 9000KVAR
500/5 (100:1)	AWP7CGC 200KVAR	AWP7CNC 400KVAR	AWP7CRC 500KVAR	AWP7DGC 2000KVAR	AWP7DKC 3000KVAR	AWP7DMC 3500KVAR	AWP7DNC 4000KVAR	AWP7DRC 5000KVAR	AWP7DTC 6000KVAR	AWP7BAD 10MVAR	AWP7BCD 12MVAR
600/5 (120:1)	AWP7CHC 240KVAR	KSC7CPC 450KVAR	AWP7CTC 600KVAR	AWP7DHC 2400KVAR	AWP7DMC 3500KVAR	KWE7DNC 4000KVAR	KSC7DPC 4500KVAR	AWP7DTC 6000KVAR	AWP7DWC 7000KVAR	AWP7BCD 10MVAR	AWP7BDC 14MVAR
800/5 (160:1)	AWP7CLC 320KVAR	KSC7CTC 600KVAR	AWP7CYC 800KVAR	AWP7DLC 3200KVAR	KSC7DPC 4500KVAR	JTA7DRC 5000KVAR	KSC7DTC 6000KVAR	AWP7DYC 8000KVAR	KSC7DZC 9000KVAR	AWP7FED 16MVAR	KSC7BFD 18MVAR
1000/5 (200:1)	AWP7CNC 400KVAR	AWP7CYC 800KVAR	AWP7DAC 1000KVAR	AWP7DNC 4000KVAR	AWP7DTC 6000KVAR	AWP7DWC 7000KVAR	AWP7DYC 8000KVAR	AWP7BAD 10MVAR	AWP7BGD 12MVAR	AWP7BGD 20MVAR	AWP7BHD 24MVAR
1200/5 (240:1)	KSC7CPC 450KVAR	KSC7CZC 900KVAR	AWP7DCC 1200KVAR	KSC7DPC 4500KVAR	AWP7DWC 7000KVAR	KWE7DYC 8000KVAR	KSC7DZC 9000KVAR	AWP7BCD 12MVAR	AWP7BDC 14MVAR	AWP7BHD 24MVAR	AWP7BJD 25MVAR
1500/5 (300:1)	AWP7CTC 600KVAR	AWP7DCC 1200KVAR	AWP7DEC 1500KVAR	AWP7DTC 6000KVAR	AWP7DZC 9000KVAR	KWE7BAD 10MVAR	AWP7BCD 12MVAR	AWP7BED 15MVAR	AWP7BFD 18MVAR	AWP7BKD 30MVAR	AWP7BMD 35MVAR
2000/5 (400:1)	AWP7CYC 800KVAR	AWP7HEC 1600KVAR	AWP7DGC 2000KVAR	AWP7DYC 8000KVAR	AWP7DNC 12MVAR	AWP7BDC 14MVAR	AWP7FED 16MVAR	AWP7BGD 20MVAR	AWP7BHD 24MVAR	AWP7BND 40MVAR	KSC7BPD 45MVAR
2500/5 (500:1)	AWP7DAC 1000KVAR	AWP7DGC 2000KVAR	AWP7DJC 2500KVAR	AWP7BAD 10MVAR	AWP7BED 15MVAR	AWP7FGD 17.5MVAR	AWP7BGD 20MVAR	AWP7BJD 25MVAR	AWP7BKD 30MVAR	AWP7BRD 50MVAR	AWP7BTD 60MVAR
3000/5 (600:1)	AWP7DCC 1200KVAR	AWP7DHC 2400KVAR	AWP7DKC 3000KVAR	AWP7BCD 12MVAR	AWP7BED 18MVAR	KWE7BGD 20MVAR	AWP7BHD 24MVAR	AWP7BKD 30MVAR	AWP7BMD 35MVAR	AWP7BTD 60MVAR	AWP7BWD 70MVAR
4000/5 (800:1)	AWP7HEC 1600KVAR	AWP7DLC 3200KVAR	AWP7DNC 4000KVAR	AWP7FED 16MVAR	AWP7HHD 24MVAR	JTA7BJD 25MVAR	AWP7BLD 32MVAR	AWP7BND 40MVAR	KSC7BPD 45MVAR	AWP7BYD 80MVAR	KSC7BZD 90MVAR
5000/5 (1000:1)	AWP7DGC 2000KVAR	AWP7DNC 4000KVAR	AWP7DRC 5000KVAR	AWP7BGD 20MVAR	AWP7BKD 30MVAR	AWP7BMD 35MVAR	AWP7BND 40MVAR	AWP7BRD 50MVAR	AWP7BTD 60MVAR	AWP7CAD 100MVAR	AWP7CCD 120MVAR

## Optional Features for AB/DB 40, AB/DB 16

### Scales

1. Uncalibrated
2. Special marked scales
3. Special legends
4. Colored markings, lines or arcs other than black.
5. Fine line marking (approximately twice the normal calibration marks — maximum 150 calibration marks
6. Black scale — white markings
7. a) Double set of numbers — Single set of divisions  
b) Triple set of numbers — Single set of divisions
8. a) Double set of numbers — Double set of divisions  
b) Triple set of numbers — Double set of divisions
9. Zero-center scales — DC ammeters, DC milliammeters, DC voltmeters, AC wattmeters and varmeters. Not available for AC ammeters, voltmeters
10. Offset-zero scale — Available for varmeters, AC wattmeters, DC ammeters and DC voltmeters

### Ratings and Calibration

11. Special calibration in accordance with data supplied by customers
12. Calibration at any angle other than vertical — Specify angle.  
Note: DC instruments can be used up to a 30° tilt from vertical without additional error
13. Terminal resistance and/or tolerance other than standard tolerance ( $\pm 15\%$ )
14. Special sensitivities for DC taut-band voltmeters. Standard sensitivities are:  
zero-left: 1000 ohms/volts  
zero-center: 2000 ohms/volts
15. Special frequency calibration  
a) Any frequency 25 to 400 Hertz.  
b) Over 400 Hertz, consult factory.  
Note: Does not apply to temperature indicators

16. Double-rated voltmeters and ammeters (includes double-marked scale if required). Double ratings should be chosen to allow a single set of divisions whenever possible. AC ammeters can have double rating only when one current is double the other (e.g., 2.5/5 amperes)  
Double-rated DC ammeters are not recommended
17. Wattmeters & varmeters with current coils rated other than 5 amperes.
18. Accuracy other than listed
19. Suppressed zero — Maximum suppression 20% of scale.

### Construction

20. Weathertight case (standard on metal case AB/DB-40, no adder. Not available on AB/DB-16 models)
21. Red manual-set pointer(s) 1 or 2 (AB/DB-40 only). Adjustable over entire scale from the front of the instrument
22. Anti-glare window AB/DB-40 only
23. Wooden-box packaging for export shipping
24. Tagging Dymotape or Paper
25. Optional extra-short case (overall depth 3.41") for metal case amps and volts only.
26. 6VDC, 12VDC, 24VDC, 48VDC backlit (red or white) available on AC and DC volt and amp units (AB/DB40).

### Standard Scale Legends

AC Volts or Kilovolts	% KW	LBS
AC Amperes, or Kiloamperes	Hz	PSIG
AC Watts, Kilowatts or Megawatts	FPS	GPH
Vars, Kilovars or Megavars	KPS	PSIA
Synchroscope	YPS	IPS
Power Factor	CPM	PPS
Hertz	FPM	RPM
Phase Angle	IPM	GPM
DC Volts, or Kilovolts	KPM	In. H <sub>2</sub> O
or Milliamperes	RPM	
DC Watts or Kilowatts	YPM	
Percent-Motor-Load Current	CPH	
Percent Horsepower	FPH	
Degrees C	IPH	
Degrees F	KPH	
Degrees K	MPH	
Degrees R	RPH	
Kilo-Ohms	YPH	
Horsepower	PPH	
Percent	PSI	
Percent Load		
VA. In HG		

The words "Spindle," "Table," "Roll," "Motor," "Turbine" can be added to the above at no extra cost. Also, when necessary, the multipliers, "X-10," "X-100," or "X-1000" will be added to these legends.

Minimum and Maximum Ratings For AB/DB 40, AB/DB 16

Indicator	Type	Minimum	Maximum
AC Voltmeter	RMS rectifier	25 Hertz 50 Volts	1000 Hertz 750 Volts
	Average rectifier	25 Hertz 8 Volts	3000 Hertz 750 Volts
AC Ammeter	RMS rectifier	25 Hertz 0.3 Ampere	1000 Hertz 30 Amperes
AC Milliammeter	RMS rectifier	25 Hertz 300 Milliamperes	1000 Hertz 1000 Milliamperes
	Average rectifier	25 Hertz 0.5 Milliamperes	3000 Hertz 100 Milliamperes
AC Wattmeter 1-phase 2-wire	Single Phase	25 Hertz 380 CW*† 190-0-190 CW*† 69 Volts 1 Ampere	1000 Hertz 760 CW*† 600 Volts 10 Amperes
AC Wattmeter 3-phase 3-wire	Polyphase	25 Hertz 380 CW*† 190-0-190 CW*†	1000 Hertz 760 CW*† 600 Volts
	Voltage Unbalanced	69 Volts 1 Ampere	10 Amperes
3-phase 4-wire	Voltage Balanced		
AC Varmeter 1-phase 2-wire	Single Phase	25 Hertz 380 CW*† 190-0-190 CW*† 69 Volts 1 Ampere	1000 Hertz 760 CW*† 600 Volts 10 Amperes
	Polyphase	25 Hertz 658 CW*† 329-0-329 CW*† 69 Volts 1 Ampere	1000 Hertz 1316 CW*† 600 Volts 10 Amperes
3-phase 3-wire	Voltage Balanced		
AC Varmeter 3-phase 4-wire	Polyphase	25 Hertz 760 CW*† 380-0-380 CW*† 69 Volts 1 Ampere	1000 Hertz 1520 CW*† 600 Volts 10 Amperes
	Voltage Balanced		
Frequency Meter		2 Hertz Span	
Synchroscope		50 Hertz	400 Hertz
Power-factor Meter 1-phase 2-wire	Single Phase	60 Hertz 120 Volts 0.1 Amperes	60 Hertz 240 Volts 5 Amperes
	Polyphase	60 Hertz 120 Volts 5 Amperes	60 Hertz 240 Volts 5 Amperes
Power-factor Meter 3-phase, 3-wire 3-phase, 4-wire	Unbalanced Systems		
Power-factor Meter 3-phase, 3-wire 3-phase, 4-wire	Polyphase	25 Hertz 120 Volts 0.1 Amperes	400 Hertz 600 Volts 5 Amperes
	Balanced System		
AC Ground Detector		25 Hertz 50 Volts	1000 Hertz 750 Volts
DC Millivoltmeter		50 Millivolts 200 Ohm/Volt	1000 Millivolts 5000 Ohm/Volt
DC Voltmeter		1 Volt 200 Ohm/Volt	750 Volts 5000 Ohm/Volt
DC Microammeter		Microamperes: DB-40-200 DB-16-300	1000 Microamperes
DC Milliammeter		1 Milliampere	1000 Milliamperes
DC Ammeter		1 Ampere	30 Amperes
	Shunt-rated	50 Millivolts	1000 Millivolts
DC Ground Detector		50 Millivolts 200 Ohms/Volts	750 Volts 5000 Ohms/Volts
Temperature 120 Volts 50-600 Hertz		180 F } Span 100 C }	250 F } Span 140 C }
		10 Ohms } cu. } —100F — 73 C }	+260 F +127 C }

† Calibrating watts

\*Applies only to 120-volt/5-ampere models; other ratings in proportion.



## SWITCHBOARD INSTRUMENTS

### Specifications, Burden Data — AC Meters

Type	Impedance in Ohms	Effective Resistance in Ohms	Inductance in Henries or Capacitance in Microfarads	Volt-amperes	Watts	Reactive Volt-amperes	Power Factor
<b>120-Volt, 60-Hertz Potential Circuit</b>							
Voltmeters, AB-16/40	28,100	28,100	0	0.51	0.51	0	1.0
Expanded-scale Voltmeters	15,400	15,400	0	0.94	0.94	0	1.0
Single phase Wattmeters* AB-16/40	6,920	4,460	14H	2.08	1.34	1.59	0.64 (Lagging)
Polyphase Wattmeters* AB-16/40							
Terminal #6 to #8 on 3W 3P	7,250	4,370	15H	2.0	1.2	1.6	0.6 (Lagging)
Terminal #8 to #11 on 4W 3P							
Terminal #2 to #8 on 3 W 3P							
Terminal #3 to #11 on 4W 3P	105,000	105,000	0	0.14	0.14	0	1.0
Power Factor Meters, AB-16/40							
Single-phase	18,320	4,660	0.15μF	0.79	0.20	0.76	0.26 (Leading)
Three-phase							
Terminal #2 to #5	above 10MΩ	above 10MΩ	—	0	0	0	—
#3 to #5	above 10MΩ	above 10MΩ	—	0	0	0	—
#2 to #3	21,200	21,200	0	0.68	0.68	0	1.0
Frequency Meters, AB-16/40							
55-65, 50-70, 58-62, 45-55	9,370	9,370	0	1.54	1.54	0	1.0
350-450	9,470	9,470	0	1.52	1.52	0	1.0
120V Synchroscope, Running	10,700	8,800	16H	1.35	1.11	.76	.827 (Lagging)
Incoming	68,600	55,500	107H	.21	.17	.11	.838 (Lagging)
240V Synchroscope, Running	33,500	28,200	48H	1.72	1.45	.92	.845 (Lagging)
Incoming	130,900	113,100	175H	.44	.38	.25	.826 (Lagging)
<b>5-Ampere, 60-Hertz Current Circuit</b>							
Ammeters, AB 16/40	0.013	0.013	0	0.32	0.32	0	1.0
Single and Polyphase Wattmeters*, AB-16/40	0.018	0.018	0	0.43	0.43	0	1.0
Single and Polyphase Varmeters*, AB-16/40	0.018	0.018	0	0.43	0.43	0	1.0
Single and Polyphase Power Factor Meters	0.036	0.036	0	0.91	0.91	0	1.0

\*Data based on a per-element basis

### Specifications, Burden Data — DC Meters

#### DC Voltmeters

Rating (Volts)	Sensitivity (Ohms Per Volt)	
	DB-40	DB-16
From 15 To 750	1,000 Zero Left 2,000 Zero Center	1,000 Zero Left 2,000 Zero Center

#### DC Millivoltmeters

Rating (mV)	Calibrated for 2-way Lead Resistance of 0.05 Ohms as standard**	Ohms Terminal Resistance ± 15%	
		DB-40	DB-16
0-50	0.05	25	25
50-0-50	0.05	50	50
0-100	0.05	50	50
100-0-100	0.05	100	100

#### DC Ammeters

Rating (Amperes)	Ohms Terminal Resistance ± 15%	
	DB-40	DB-16
0-1	0.05	0.05
0-5	0.01	0.01
0-10	0.005	0.005
0-15	0.0033	0.0033
0-20	0.0025	0.0025
0-30	0.0017	0.0017

#### DC Milliammeters

Rating (mA)	Ohms Terminal Resistance ± 15%	
	DB-40	DB-16
0-1	185	185
0-2	18	18
0-5	10	10
0-10	5	5
0-30	1.7	1.7
0-50	1	1
0-100	0.5	0.5
0-200	0.25	0.25
0-300	0.17	0.17
0-500	0.1	0.1
10-50	12.5	12.5
4-20	6	6
1-5	26.5	26.5

#### DC Microammeters

Rating (μA)	Ohms Terminal Resistance ± 15%	
	DB-40	DB-16
0-200	1,600	1,600
0-300	1,050	1,050
0-500	630	630

\*\*Internal lead adjustment potentiometer can be adjusted for other lead resistances

Standard Connections

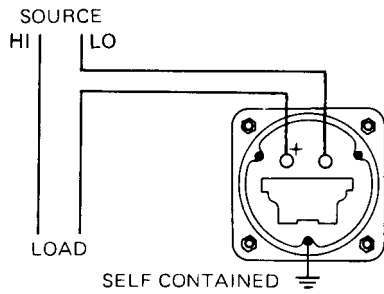

**AC Ammeter  
103131xxxx**

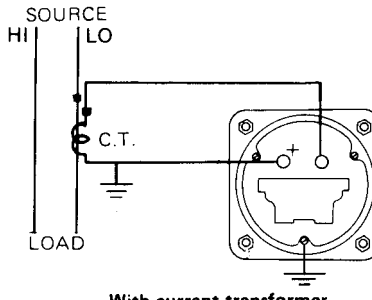

With current transformer  
**AC Ammeter  
103131xxxx**

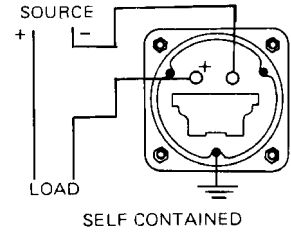

**DC Ammeter  
10311-xxxx**

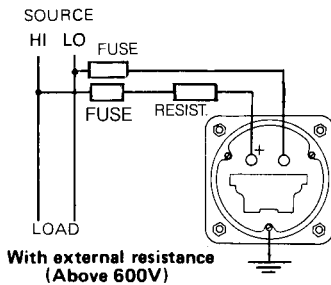

With external resistance  
(Above 600V)  
**AC Voltmeter  
103021xxxx7xxx**

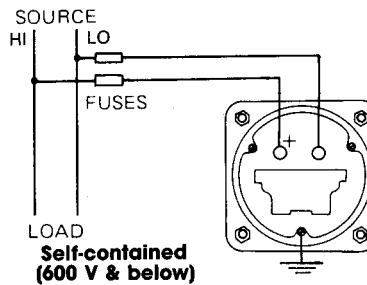

Self-contained  
(600 V & below)  
**AC Voltmeter  
103021xxxx**

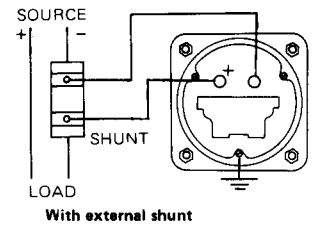

With external shunt  
**DC Ammeter  
10312-xxxx**

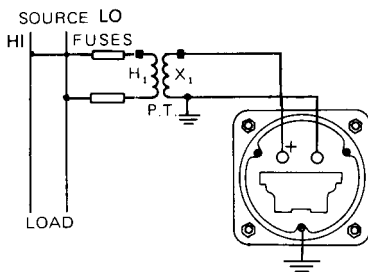

With potential transformer  
**AC Voltmeter  
103021xxxx**

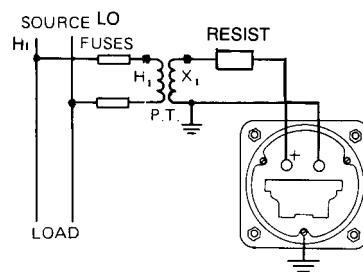

With potential transformer &  
external resistor  
**AC Voltmeter  
103021xxxx7xxx**

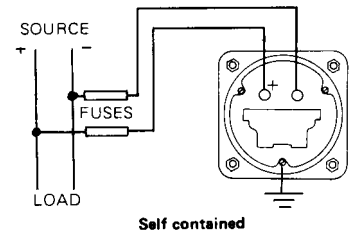

Self contained  
**DC Voltmeter  
10301-xxxx**

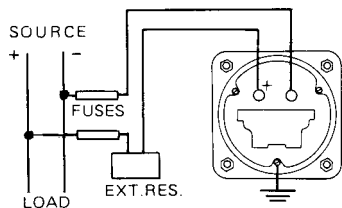

With external resistor  
**DC Voltmeter  
10317-xxxx  
10311-xxxx**

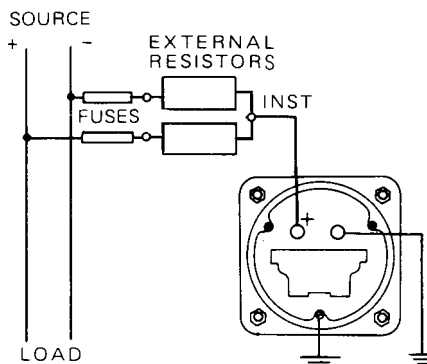

**DC Ground Detector**

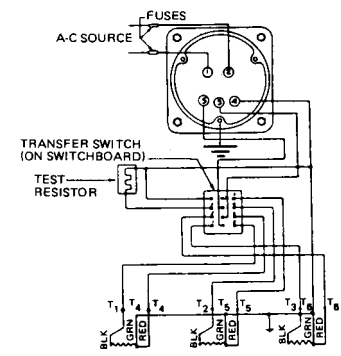

**Temperature Indicator  
103502xxxx**

NOTE: UL requires a separate grounding terminal that is provided above a ground symbol (≡).  
Connection diagrams for AB/DB16 and AB/DB14 Ammeters and Voltmeters are same as AB/DB40 depicted above.

Standard Connections

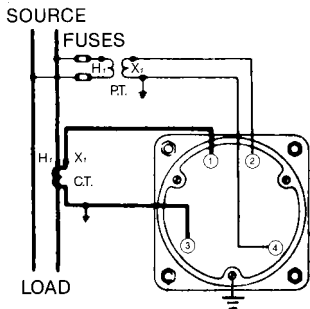

Single-phase wattmeter and Varmeter with current transformer and potential transformer  
 10321-xxxx7xxx (watt)  
 103702xxxx7xxx (watt)  
 10331-xxxx7xxx (var)  
 103762xxxx7xxx (var)

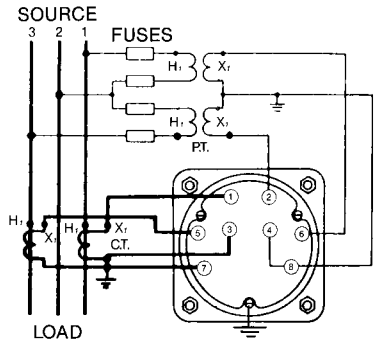

Three-wire, three-phase wattmeter with current transformer and potential transformer  
 10322-xxxx7xxx  
 103712xxxx7xxx

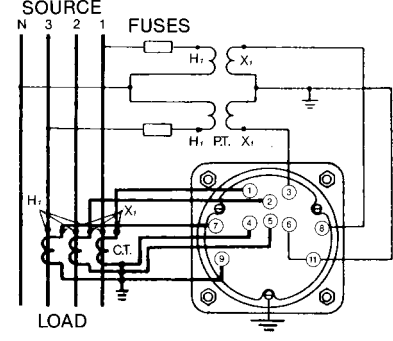

Four-wire, three-phase wattmeter with current transformer and potential transformer (Balanced V)  
 10325-xxxx7xxx  
 103732xxxx7xxx

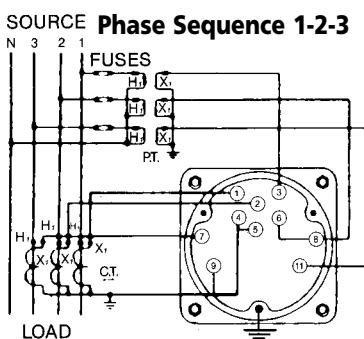

Connections for 2 1/2 element varmeter, without phase shifting transformer; used to measure vars on 4 wire, 3 phase circuits, with potential transformers (connected yy) and three current transformers: (Balanced V)  
 10329-xxxx7xxx, K = 1.1547  
 103742xxxx7xxx  
 See Note 1. Page 12

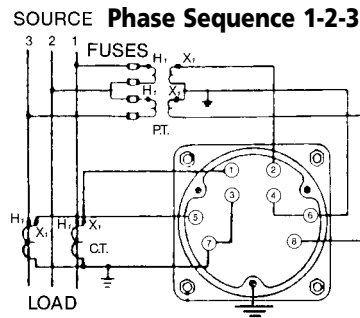

Connections for polyphase varmeters for 3 wire, 3 phase. (Balanced V)  
 103812xxxx7xxx  
 10328-xxxx7xxx

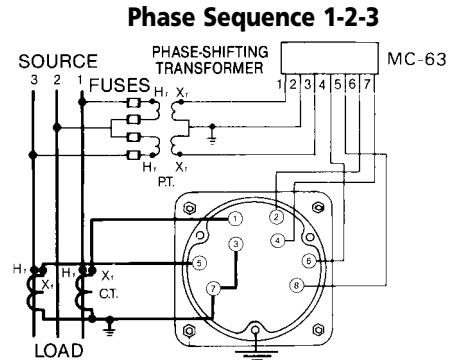

Connections for 3 wire, 3 phase varmeter with phase shifting transformer. (Balanced V)  
 10332-xxxx7xxx  
 103772xxxx7xxx

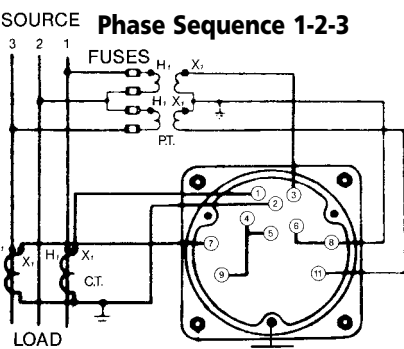

Connections for 2 1/2 element varmeter used to measure vars on a 3 wire, 3 phase circuit. (Balanced V)  
 10329-xxxx7xxx K = 1.1547  
 103742xxxx7xxx

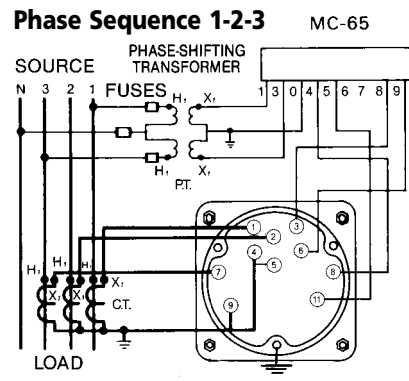

Connections for 4 wire, 3 phase varmeter with phase shifting transformer. (Balanced V)  
 10334-xxxx7xxx  
 103792xxxx7xxx

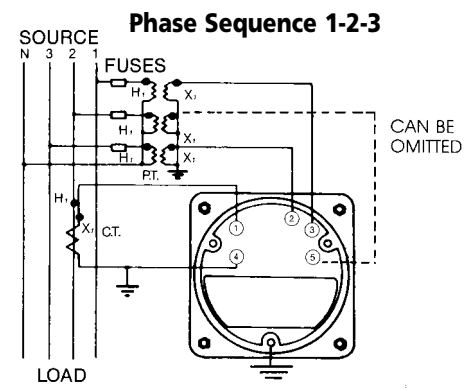

Connections for power-factor meters with 4 wire 3 phase circuits with current transformer and potential transformers. If transformer secondary voltage is 120, power-factor instrument should be rated 208 volts.  
 103402xxxx (Balanced System)

NOTE: UL requires a separate grounding terminal that is provided above a ground symbol ( = ).

Standard Connections

Phase Sequence 1-2-3

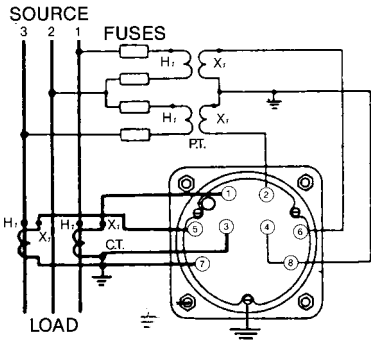

Three-wire, Three-phase Power Factor meter with current transformers and potential transformers. (Unbalanced system) 103462xxxx

Phase Sequence 1-2-3

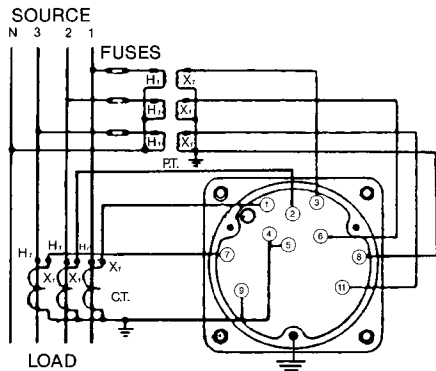

Four wire, three phase power factor meter with current transformers and potential transformers (Unbalanced System) 103472xxxx

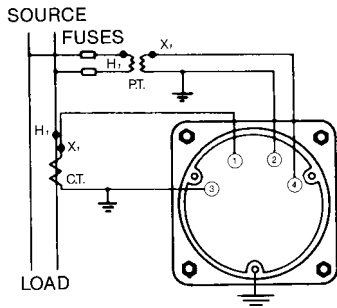

Single-phase power-factor meter with current transformer and potential transformer 103412xxxx

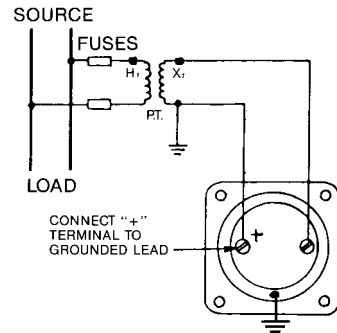

Frequency Meter with potential transformer 103372xxxx

Phase Sequence 1-2-3

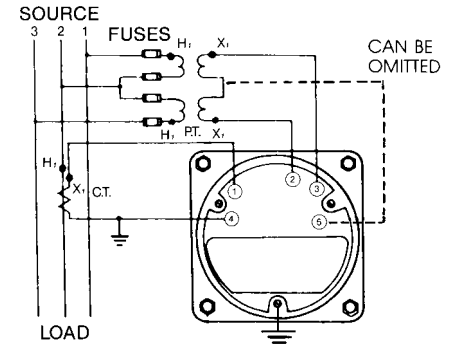

Three-wire, three-phase power-factor meter with current transformer and potential transformers (Balanced System) 103402xxxx

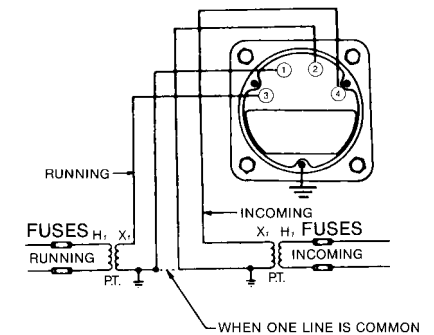

Synchroscope with potential transformers 106452xxxx

NOTE: UL requires a separate grounding terminal that is provided above a ground symbol (  $\equiv$  ).

Dimensions and Panel Drilling For AB/DB 16 & AB/DB 40 (Metal Case)

Short Case

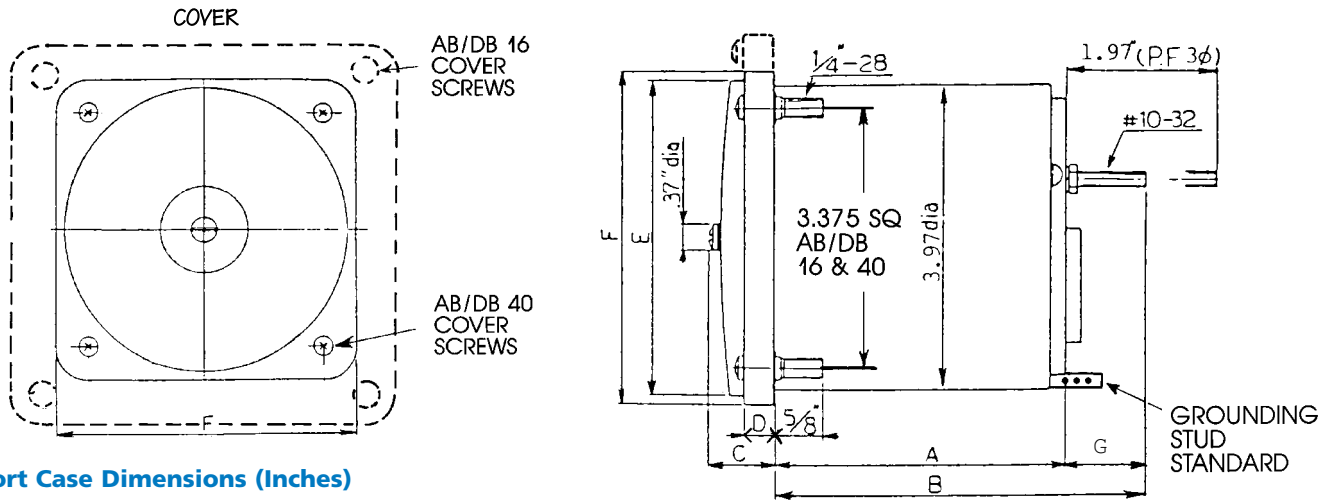

Short Case Dimensions (Inches)

	AB / DB-40			AB / DB-16	
	AC V / A — DC V / A Frequency Temperature Tachometer Synchroscope	AC V / A — DC V / A Extra Short Case	Power Factor 1Φ (3Φ3w/4w)	AC V / A — DC V / A Frequency Temperature Tachometer Synchroscope	Power Factor 1Φ (3Φ3w/4w)
A	3.79	2.89	3.79	3.75	3.75
B	4.85	3.41	4.85 (5.76)	4.81	4.81 (5.72)
C	0.86	0.86	0.86	0.88	0.88
D	0.32	0.32	0.32	0.38	0.38
E	4.09	4.09	4.09	8.20	8.20
F	4.33	4.33	4.33	8.69	8.69
G	1.06	0.52	1.06	1.06	1.06

Long Case

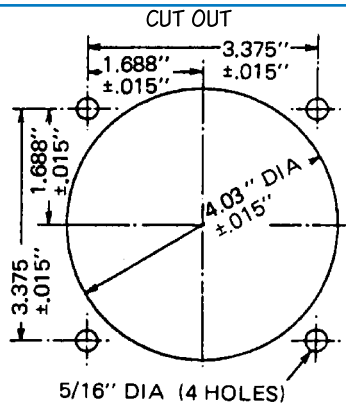

Cut-out and Panel Drilling Dimensions.  
AB/DB 40 & 16

Long Case Dimensions (Inches)

	AB / DB-40	AB / DB-16
	Wattmeter Varmeter*	Wattmeter Varmeter
A	5.22	5.19
B	6.79	6.76
C	0.86	0.88
D	0.32	0.38
E	4.09	8.20
F	4.33	8.69

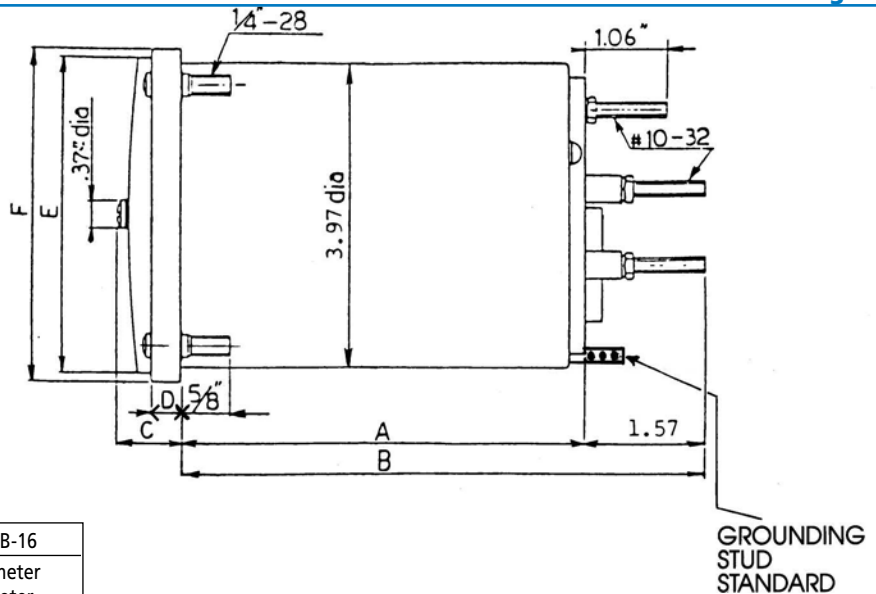

\*Short case dimensions in first column above apply to varmeter for use with external phase shifters (10332—, 10377—, 10334—, 10379—.)



Mechanical Specifications

Enclosure: DB-40 "Short" Case; cold rolled steel with protective coating

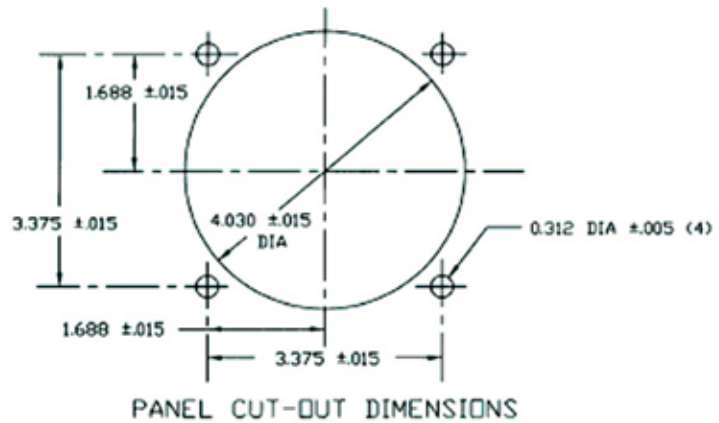
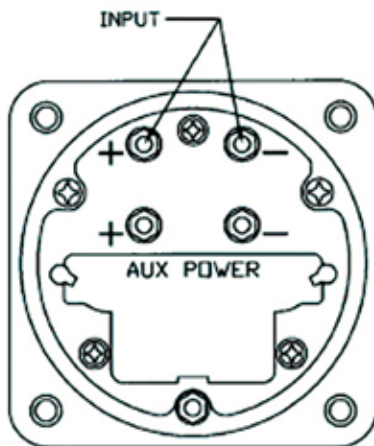
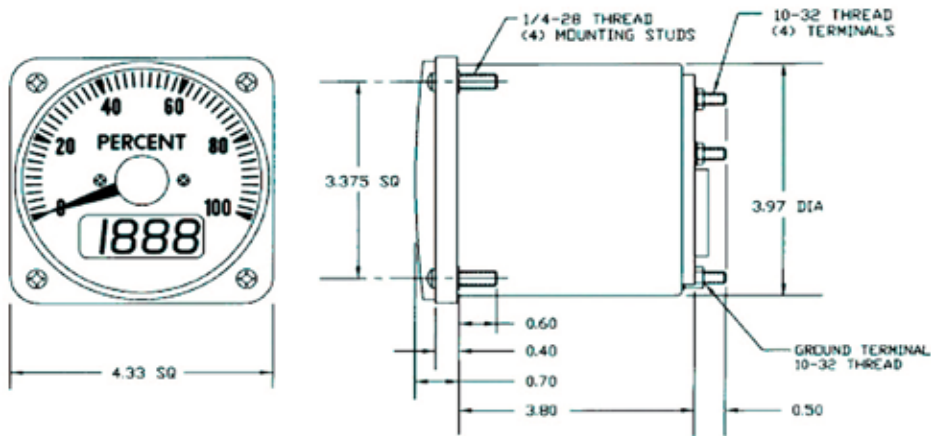

Outline Dimensions

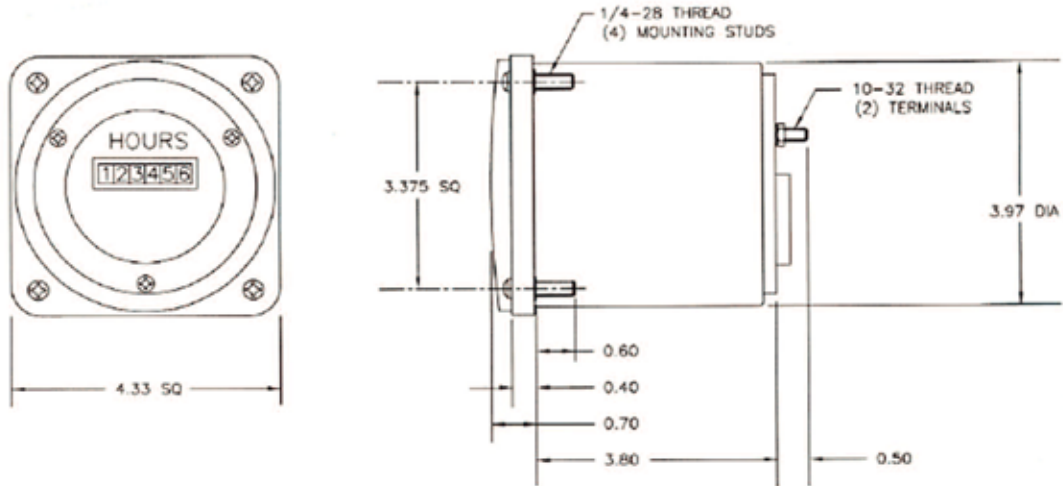

Panel Cutout

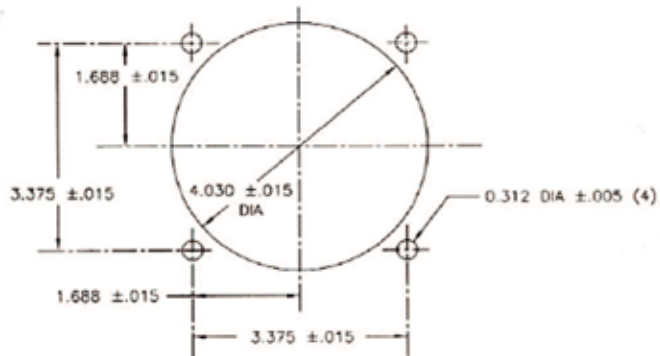

**DIMENSIONS AND PANEL DRILLING**

**Plastic case AB / DB40 Ammeters and Voltmeters**

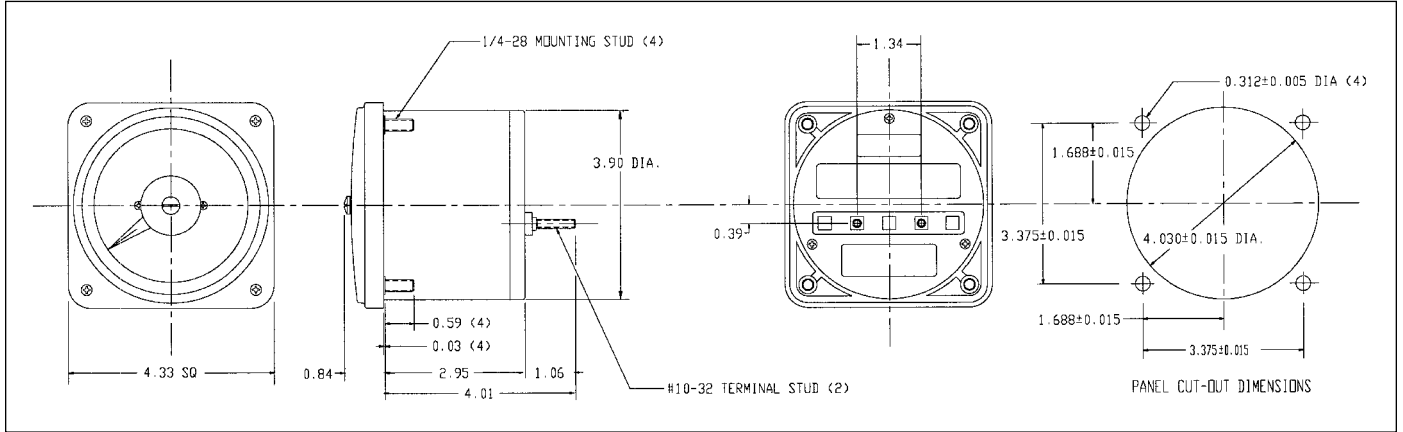

**High shock AB / DB14 Ammeters and Voltmeters**

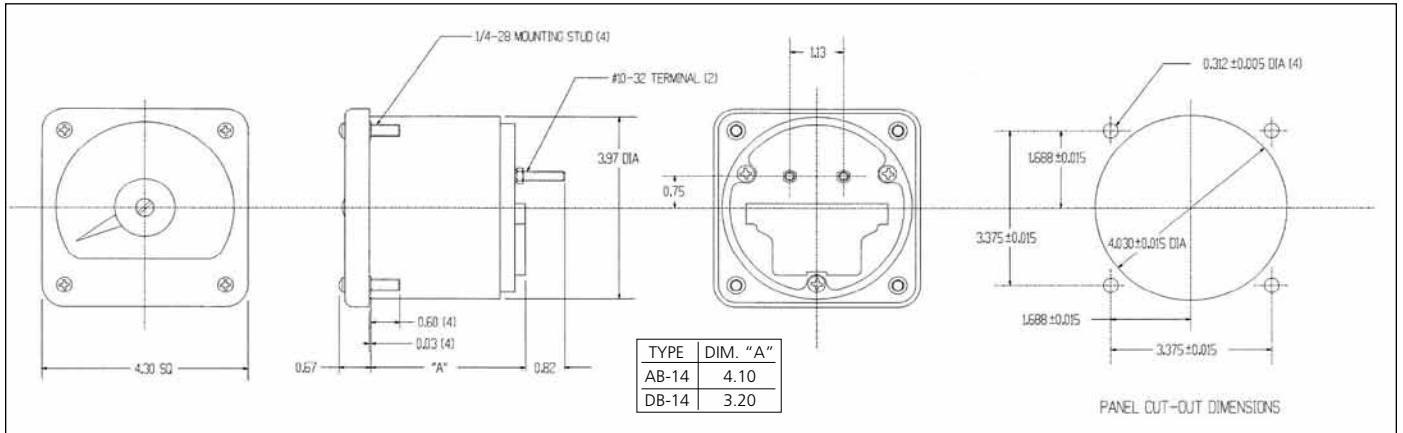

**Illuminated AB / DB17 Railroad type Ammeters and Voltmeters**

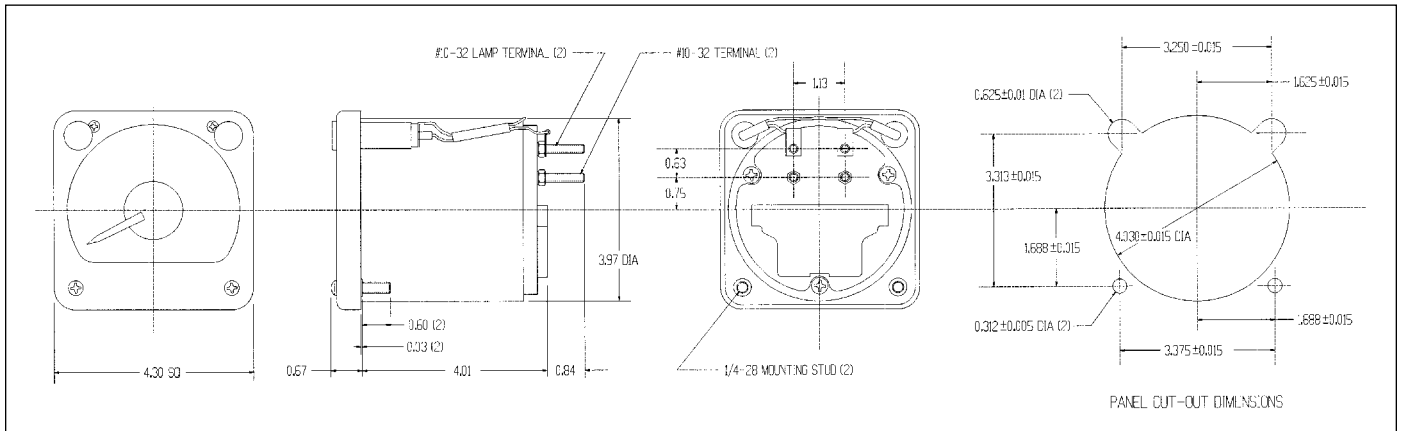

TYPE 180 SINGLE EDGEWISE

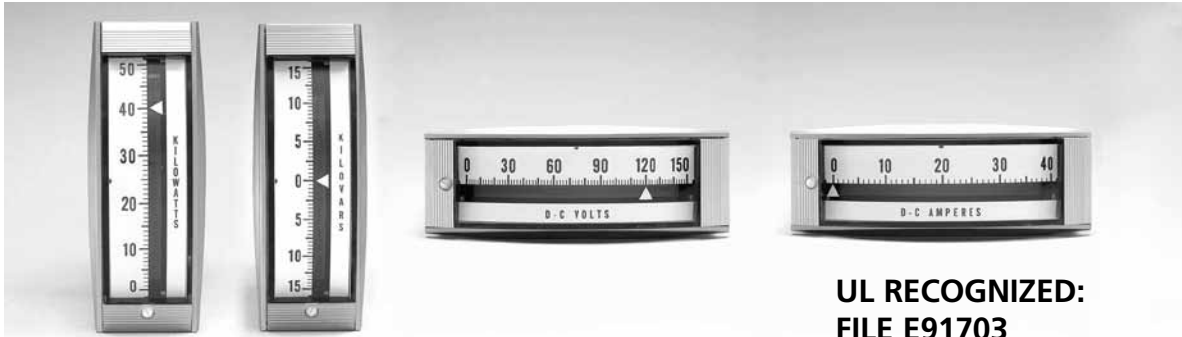

**UL RECOGNIZED:  
FILE E91703**

**Specifications**

**Accuracy Class:**

Standard — ± 1.5% of full-scale span for DC horizontal and vertical and AC horizontal.  
± 2% for AC vertical.

Suppressed zero (mechanical) — ± 2% of full scale span.

AC Rectifier-type Ammeters and Voltmeters— Standard ± 2.5% on 60-Hertz sine wave at 25° C.

**Scales (Standard):**

Ranges — (see following page)

Length — 4.448 inches

Degrees rotation 60 degrees

Color — Background - White

Numerals - Black

Legend - Black

Scale Divisions - Black

Numeral Height — ¼ inch

Illumination — Refer to factory

Number of scale divisions — 100 maximum

Scale linearity — DC - linear

AC - non-linear

Maximum number of letters (counting spaces as letters) on vertical meters, 25; on horizontal meters, 30.

**Repeatability:** ± 2% of full scale

**Overload:**

Sustained — 120% for AC and DC voltmeters.  
120% for 8 hours for AC and DC ammeters.

Momentary — 10 times rated current applied for 10 consecutive intervals of ½ second with one-minute intervals between successive applications for AC and DC ammeters.  
Mechanical overload same as momentary overload for ammeters.

**Response Time:**

AC — 4 seconds maximum

DC — 2.5 seconds maximum ≥ 1 mA

4 seconds maximum < 1 mA

**Overshoot:**

40% full scale angle maximum

**Insulation Level:**

Operating — 600 volts

Hi-pot — 5000 volts rms terminals to case for one minute

**Mounting Position For Both Horizontal and Vertical Meters:**

Mounting to a Vertical Panel is standard. If other mounting angle is necessary, then angle must be specified and instrument calibrated for the specified angle.

**Operating Environment:**

Temperature (Standard) — (-4° to +150°F)  
(-20°C to +65°C)

Pressure — Atmospheric

Shock — 50 G's

Maximum magnetic field without external shielding —

(Standard) - DC or AC, 1 gauss for 3% accuracy

**Case:**

Material — Base Polycarbonate

Finish — Spray painted

Color — (Standard) - Aluminum

(Optional) - Black

Pointer color — White

Window and Case — Polycarbonate

Magnetic Shielding — DC, self-shielding

AC, soft iron shielding

Gasketed cover (weather resistant) standard

Type Terminals — Stud type

**Movement:**

AC — Iron vane pivot and jewel

DC — Pivot and jewel

**Weight:**

AC — 19 oz.

DC — 18 oz.

Shipping weight — approx. 30 oz.

**Burden Data**

Type	Impedance in Ohms	Effective Resistance in Ohms	Inductance in Henries	Volt-amperes	Watts	Reactive Volt-amperes	Power Factor
------	-------------------	------------------------------	-----------------------	--------------	-------	-----------------------	--------------

**120-VOLT, 60-HERTZ POTENTIAL CIRCUIT**

Voltmeters	18,667	18,658	1.546	1.205	1.204	0.0545	0.9993
------------	--------	--------	-------	-------	-------	--------	--------

**5-AMPERE, 60-HERTZ CURRENT CIRCUIT**

Ammeters	0.00832	0.00792	6.75x10 <sup>-6</sup>	0.208	0.1978	0.064	0.9520
----------	---------	---------	-----------------------	-------	--------	-------	--------

DC AMMETERS PIVOT & JEWEL

Scale and Rating	Terminal Resistance, Ohms	±1.5% Accuracy Vertical	±1.5% Accuracy Horizontal
------------------	---------------------------	-------------------------	---------------------------

DC AMMETERS — SELF-CONTAINED

0-50µA	4735	180 113 CYCY	180 111 CYCY
0-100µA	1480	180 113 DRDR	180 111 DRDR
0-200µA	650	180 113 EAEA	180 111 EAEA
0-500µA	226	180 113 EMEM	180 111 EMEM
0-800µA	562	180 113 EWEV	180 111 EWEV
0-1 mA	40	180 113 FAFA	180 111 FAFA
0-2 mA	20	180 113 FGFG	180 111 FGFG
0-5 mA	10	180 113 FXFX	180 111 FXFX
0-10 mA	5.0	180 113 GZGZ	180 111 GZGZ
0-50 mA	1.0	180 113 HYHY	180 111 HYHY
0-100 mA	0.5	180 113 JRJR	180 111 JRJR
0-200 mA	0.25	180 113 KAKA	180 111 KAKA
0-500 mA	0.10	180 113 KMKM	180 111 KMKM
0-800 mA	0.062	180 113 KWKW	180 111 KWKW
0-1 A	0.05	180 113 LALA	180 111 LALA
0-2 A	0.025	180 113 LELE	180 111 LELE
0-5 A	0.010	180 113 LSL SLS	180 111 LSL SLS
0-10 A	0.005	180 113 MTMT	180 111 MTMT
0-15 A	0.003	180 113 NDND	180 111 NDND
0-20 A	0.0025	180 113 NGNG	180 111 NGNG
0-30 A	0.00167	180 113 NLNL	180 111 NLNL
0-40 A	0.00125	180 113 NPNP	180 111 NPNP
0-50 A	0.001	180 113 NTNT	180 111 NTNT

DC AMMETERS — SHUNT-RATED 50 MV

(Lead Resistance = .05Ω-.07Ω)

0-10 A	12.5	180 123 ECMT	180 121 ECMT
0-20 A	12.5	180 123 ECNG	180 121 ECNG
0-30 A	12.5	180 123 ECNL	180 121 ECNL
0-40 A	12.5	180 123 ECNP	180 121 ECNP
0-60 A	12.5	180 123 ECNW	180 121 ECNW
0-80 A	12.5	180 123 ECPD	180 121 ECPD
0-100 A	12.5	180 123 ECPK	180 121 ECPK
0-200 A	12.5	180 123 ECRL	180 121 ECRL
0-300 A	12.5	180 123 ECRX	180 121 ECRX
0-400 A	12.5	180 123 ECSC	180 121 ECSC
0-500 A	12.5	180 123 ECSF	180 121 ECSF
0-600 A	12.5	180 123 ECSJ	180 121 ECSJ
0-800 A	12.5	180 123 ECSN	180 121 ECSN
0-1 kA	12.5	180 123 ECVA	180 121 ECVA
0-50 mV	12.5	180 123 EC†	180 121 EC†
50-0-50 mV	25	180 124 EC†	180 122 EC†

† Order by Description.

DC AMMETERS — SHUNT-RATED 100 MV

(Lead Resistance = .04Ω-.08Ω)

0-100mV	25	180 123 GB†	180 121 GB†
100-0-100mV	50	180 124 GB†	180 122 GB†

† Order by Description.

DC MILLIAMMETERS — MECHANICALLY ZERO-SUPPRESSED, LIVE-ZERO, SELF-CONTAINED

(To read output of process transmitters, blank legend)

Rating	Scale	±2% Accuracy Vertical	±2% Accuracy Horizontal
1-5 mA	§	180 183 FYAA 8ABA	180 181 FYAA 8ABA
4-20mA	§	180 183 HEAA 8ABA	180 181 HEAA 8ABA
10-50mA	§	180 183 HXAA 8ABA	180 181 HXAA 8ABA

§ Pencil calibrated points at .25%, 50%, 75%, 100% of full-scale position

DC VOLTMETERS — SELF CONTAINED

Scale and Rating	Terminal Resistance, Ohms	±1.5% Accuracy Vertical	±1.5% Accuracy Horizontal
0-1 V	1000	180 013 LALA	180 011 LALA
0-5 V	5000	180 013 LSL SLS	180 011 LSL SLS
0-15 V	15000	180 013 NDND	180 011 NDND
0-30 V	30000	180 013 NLNL	180 011 NLNL
0-50 V	50000	180 013 NTNT	180 011 NTNT
0-80 V	80000	180 013 PDPD	180 011 PDPD
0-150 V	150000	180 013 PZPZ	180 011 PZPZ
0-300 V	300000	180 013 RXRX	180 011 RXRX
0-600 V	600000	180 013 SJSJ	180 011 SJSJ
150-0-150 V	150000	180 014 PZPZ	180 012 PZPZ
300-0-300 V	300000	180 014 RXRX	180 012 RXRX

AC AMMETERS — 40/70 HZ, IRON-VANE TYPE

Scale	Transformer Rating	±2% Accuracy Vertical	±1.5% Accuracy Horizontal
0-1 A	Self-Contained	180 143 LALA	180 141 LALA
0-3 A		180 143 L L J L	180 141 L L J L
0-5 A		180 143 L S L S	180 141 L S L S
0-10 A		180 143 M T M T	180 141 M T M T
0-15 A		180 143 N D N D	180 141 N D N D
0-20 A		180 143 N G N G	180 141 N G N G
0-30 A		180 143 N L N L	180 141 N L N L
0-50 A		180 143 N T N T	180 141 N T N T

AC AMMETERS — TRANSFORMER-RATED - 5 AMP

0-10 A	10/5	180 143 LSMT	180 141 LSMT
0-15 A	15/5	180 143 LSND	180 141 LSND
0-20 A	20/5	180 143 L S N G	180 141 L S N G
0-25 A	25/5	180 143 L S N J	180 141 L S N J
0-30 A	30/5	180 143 L S N L	180 141 L S N L
0-40 A	40/5	180 143 L S N P	180 141 L S N P
0-50 A	50/5	180 143 L S N T	180 141 L S N T
0-75 A	75/5	180 143 L S P B	180 141 L S P B
0-100 A	100/5	180 143 L S P K	180 141 L S P K
0-150 A	150/5	180 143 L S P Z	180 141 L S P Z
0-200 A	200/5	180 143 L S R L	180 141 L S R L
0-300 A	300/5	180 143 L S R X	180 141 L S R X
0-400 A	400/5	180 143 L S S C	180 141 L S S C
0-500 A	500/5	180 143 L S S F	180 141 L S S F
0-600 A	600/5	180 143 L S S J	180 141 L S S J
0-800 A	800/5	180 143 L S S N	180 141 L S S N
0-1 kA	1000/5	180 143 L S V A	180 141 L S V A
0-1.2 kA	1200/5	180 143 L S V B	180 141 L S V B
0-1.5 kA	1500/5	180 143 L S V C	180 141 L S V C
0-2 kA	2000/5	180 143 L S V E	180 141 L S V E
0-3 kA	3000/5	180 143 L S V J	180 141 L S V J
0-4 kA	4000/5	180 143 L S V N	180 141 L S V N

AC VOLTMETERS — 60 HZ, IRON-VANE

0-150 V	Self-Contained	180 033 PZPZ	180 031 PZPZ
0-300 V		180 033 RXRX	180 031 RXRX
0-500 V		180 033 SFSF	180 031 SFSF
0-600 V		180 033 SJSJ	180 031 SJSJ

AC VOLTMETERS — TRANSFORMER RATED 150 V

0-300 V	240/120	180 033 PZRX	180 031 PZRX
0-600 V	480/120	180 033 PZSJ	180 031 PZSJ
0-750 V	600/120	180 033 PZSM	180 031 PZSM
0-3 kV	2400/120	180 033 PZVJ	180 031 PZVJ
0-5.25 kV	4200/120	180 033 PZVV	180 031 PZVV
0-6 kV	4800/120	180 033 PZVX	180 031 PZVX
0-9 kV	7200/120	180 033 PZWJ	180 031 PZWJ
0-15 kV	12000/120	180 033 PZWZ	180 031 PZWZ
0-18 kV	14400/120	180 033 PZXE	180 031 PZXE



## Type 180 Optional Features

### Scale Variations

1. Blank Scales
2. Special marked scales (maximum 100 divisions; Ref. Notes 3 and 4)
3. Special Legends (Ref. Notes 3 and 4)
4. Colored markings, lines, bars, etc.
5. Zero-center Scale DC instruments

### Ratings and Calibration

6. Unlisted ratings. Contact factory for other than listed ratings.
7. Offset-zero scale (DC meters only)
8. Special calibrations in accordance with data supplied by customer
9. Calibration for use on other than vertical panel
10. Calibration for use on 400 Hertz or other unlisted frequency.
11. High-sensitivity voltmeters (See Note 2)
12. Special-terminal resistance
13. Internal mounted rheostat
14. Rectifier-type voltmeters 2.5 percent.
15. 1 percent accuracy (DC only)
16. Suppressed zero with operable zero set (DC only) (See Note 1)

### Construction

17. Internal illumination
18. Red pointer (Day-glo)
19. Anti-glare window
20. Black trim case

4. Type 180 scales and legends are individual parts separated by a space for the pointer. Only one set of divisions can be marked on a scale.
5. No charge for electrical legends.

### Notes:

1. Suppressed zero — Available only on DC models up to a maximum suppression of 20 percent of full-scale value. Note: Accuracy is affected on suppressed-zero instruments.
2. High-sensitivity voltmeters — DC voltmeters can be offered up to 20,000 ohms/volt. Voltmeters of high sensitivity draw less current from the circuit and are used on applications where the circuit current is so low that instrument resistance will appreciably affect circuit operation.
3. Special legends and/or scales may be obtained by special order. Maximum number of letters (counting spaces as letters) on vertical instruments is 25; on horizontal instruments, 30. Exact wording must be clearly indicated as to spelling, abbreviation, spacing, etc.

## Dimensions and Panel Cutout

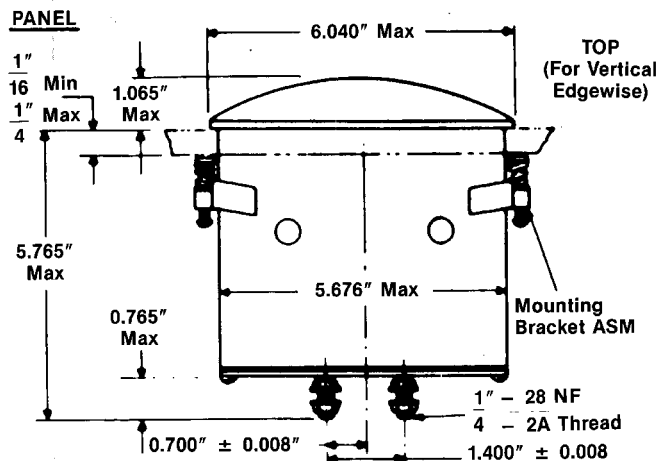
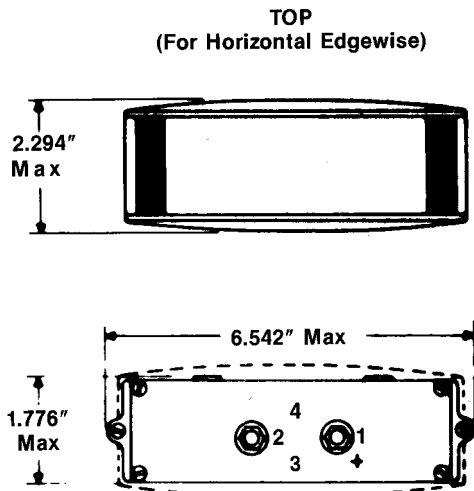

**DIMENSIONS FOR TYPE 180 INSTRUMENTS**  
**DWG B3147K22**

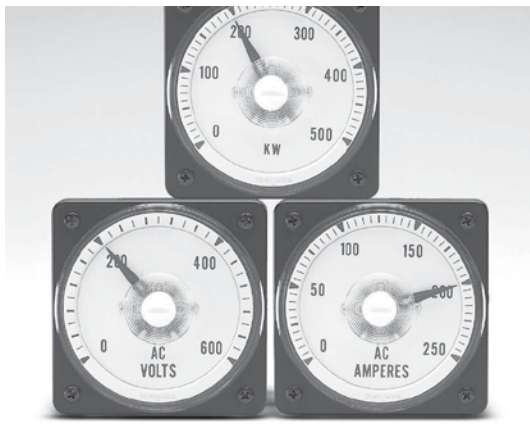

## Miniature Switchboard Instruments — 2180 Series

### GENERAL SPECIFICATIONS

Full Scale Deflection: 250° taut band movement  
 Full Scale Length: Approx. 140mm (5.5")  
 Pointer: Sword type, black  
 Scale Plate: Platform type, white  
 Case: ABS resin, black  
 Cover: Methacrylic acid resin with antistatic processing on both sides.  
 Standard color . . . Black (Munsell N. 1.5/0) or jade green (Munsell 7.5 BG4/1.5)

Terminal Plate: Phenol resin, black  
 Mounting Screw: 5mm dia.  
 Measuring Terminal: 5mm dia (nut type)  
 Operating Temperature Range: 0 to 40° C (32 to 104° F)  
 Storage Temperature Range: -10 to 50° C (14 to 122° F)  
 Dielectric Strength: 2,600 V AC for one minute between electric circuit and case  
 Watts, Vars, Unbalanced Power Factor supplied with external transducer.

Model Type		Ranges Available	Standard Ratings and Scales	Catalog Number	Operating Principle	Accuracy
DC	Ammeters	500µA ~ 30A	See Table On Next Page	2181A00	Moving coil type	±1.5% of full scale value
	Voltmeters	30V ~ 300V		2181A00		
AC	Ammeters	500µA ~ 30A		2182A00	RMS sensing transducer type	±1.5% of full scale value
	Voltmeters	3V ~ 600V		2182A00		

Type	Rating	Connection	Voltage Load Current	Elements	Catalog Number	Operating Principle	Accuracy	
AC	Wattmeters	Single-phase	Unrestricted	1	2185A31	Feedback Time Division Multiplier Transducer*	±1.5% of full scale value	
			Unrestricted					
		3-phase 3-wire	Balanced	2	2185A35			
			Unrestricted					
		3-phase 4-wire	Balanced	2-1/2	2185A34			
			Unrestricted					
	3-phase 4-wire	Unrestricted	3	2185A36				
		Unrestricted						
	Varmeters	Single-phase	Unrestricted	1	2186A31		Feedback Time Division Multiplier Transducer*	±1.5% of full scale value
			Unrestricted					
		3-phase 3-wire	Balanced	2	2186A33			
			Unrestricted					
		3-phase 3-wire	Unrestricted	2	2186A35			
			Unrestricted					
		3-phase 4-wire	Balanced	2-1/2	2186A34			
			Unrestricted					
3-phase 4-wire	Unrestricted	3	2186A36					
	Unrestricted							
Power Factor Meters	120V/5A or 240V/5A	Single-phase	Unrestricted	1	2187A31	Phase angle sensing transducer	±5.0% of Scale Length	
			Unrestricted					
	3-phase 3-wire	Balanced	1	2187A33				
		Balanced						
	3-phase 3 wire	Unrestricted	2	2187A35				
		Unrestricted						
3-phase 4-wire	Unrestricted	3	2187A36					
	Unrestricted							
Frequency Meters	115V or 230V	45-55 Hz, 55-65 Hz 45-66 Hz Rating Available			2188A30	Frequency sensing transducer type	±0.5% of center frequency	

\*Instrument is furnished with external transducer. Contact Yokogawa for transducer outline and connection drawings.

## 2180 SERIES STANDARD RATINGS AND SCALES

Example: 218100-AFA-BL is a 0-1mA rating & scale with black cover

### DC Ammeters and Voltmeters

Model Number	Suffix	Rating and scale
<b>2181A 00-</b>		
Full scale value (zero left)	AEM-	500 $\mu$ ADC
	AFA-	1mADC
	AFG-	2mADC
	AHF-	20mADC
	AKM-	500mADC
	ALA-	1ADC
	ALS-	5ADC
	AMT-	10ADC
	AND-	15ADC
	ANG-	20ADC
	ANL-	30ADC
	A01-	50mVDC (shunt-rated)*
	A05-	100mVDC (shunt-rated)*
	VNL-	30VDC
	VNT-	50VDC
	VPK-	100VDC
	VPZ-	150VDC
VRX-	300VDC	
V01-	1mADC (external multiplier)*	
2181 Suppressed zero	35-	10 to 50mADC*
	36-	4 to 20mADC*
	37-	1-5VDC*
Cover assembly	BG	Munsell green
	BL	Munsell black

### AC Ammeters and Voltmeters

Model Number	Suffix	Rating and scale
<b>2182A 00-</b>		
Full scale value (zero left)	AEM-	500 $\mu$ AAC
	AFA-	1mAAC
	AFG-	2mAAC
	AHF-	20mAAC
	AKM-	500mAAC
	ALA-	1AAC
	ALC-	1.5AAC
	ALS-	5AAC
	A42-	5AAC (for external CT)*
	AMF-	7.5AAC
	AMT-	10AAC
	ANL-	30AAC
	VNL-	30VAC
	VNT-	50VAC
	VPB-	75VAC
	VPK-	100VAC
	VPZ-	150VAC
	V12-	150VAC (for external PT)*
	VRX	300VAC
	VSI-	600VAC
V20-	70-130VAC (expanded scl.)*	
V21-	140-260VAC (exp. scale)*	
Cover assembly	BG	Munsell green
	BL	Munsell black

Note: \* For ratings and/or scales not listed, please specify as similar to closest rating above and describe in detail.

## DIMENSIONS AND PANEL DRILLING

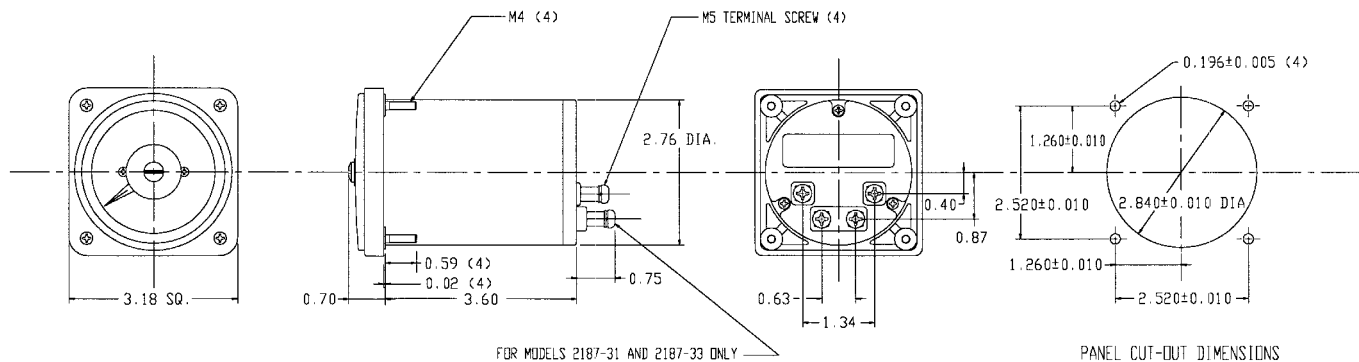

Shipping weight 1.1 lbs.

## Rudder Meter

This series of back-lit meters provides a continuous analog indication of the rudder position of a boat or ship based on an input signal from a position transducer.



### ■ Features

- 3.1" diameter indicator face with white pointer
- +/- 125° element/pointer movement
- Customizable scaling/markings, colors, and logos
- Span adjustment for voltage input, span and zero adjustment for resistance bridge input (no adjustment for current input)
- Incandescent T3 ¼ wedge type bulb 12 or 24 VDC, replaceable from the back of the unit
- Accuracy +/- 2.5 degrees (for positional accuracy of the rudder, not including sensor error, multiply full scale rudder deflection by 0.02)
- Dielectric Withstand Voltage of 1000 VAC/60 Hz from input to can for 10 seconds
- Dielectric anodized aluminum can and brass hardware
- Waterproof from front of panel, dust proof from back of panel

### ■ Model And Suffix Codes

Digits 1, 2, 3	Digits 4 & 5	Digit 6	Digits 7	Digits 8, 9	Digits 10, 11, 12, 13
Model	Input Type	Zero Pointer Position	Back Light Voltage (+/- 15%)	Factory Code	Scale Designator
RM3: Nominal 3.1" round rudder position meter	A1: +/- 1 mA DC (42 Ω terminal resistance)	U: Up pointer zero position	1: 12 V DC	-1	Established at time of order
	A2: +/- 500 μA DC (185 Ω terminal resistance)	D: Down pointer zero position	2: 24 V DC		
	V1: +/- 100 mV DC				
	V2: +/- 200 mV DC				
	V3: +/- 300 mV DC				
	V4: +/- 400 mV DC				
	V5: +/- 500 mV DC				
	R1: 500 ohm resistance bridge*				

\* Requires a user supplied 10 V DC - 40 V DC power supply (50 mA maximum current draw).

Example: RM3A1U1-1/\_\_\_ . RM3 rudder meter with ± 1 mADC input, up pointer zero position, 12 V DC back light voltage. Other features defined by the last three characters of the model number that are established at the time of order.

# SWITCHBOARD INSTRUMENTS

## Mechanical Dimensions

Inches

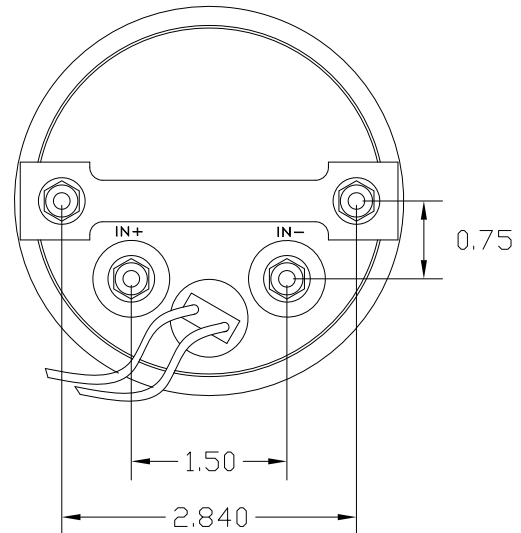
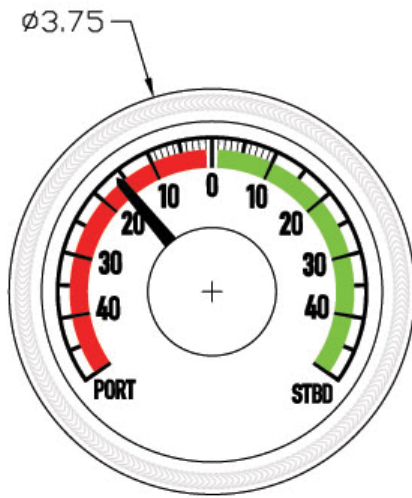

Current input

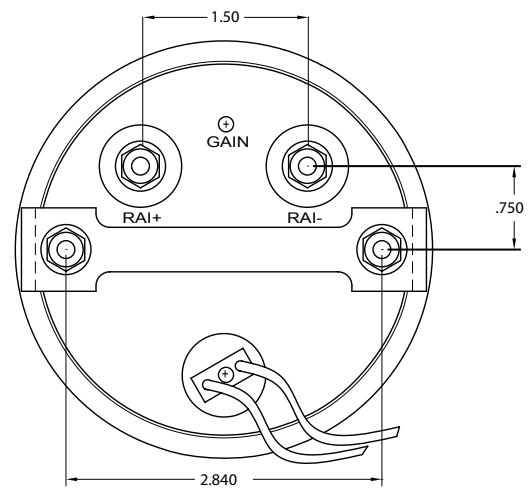
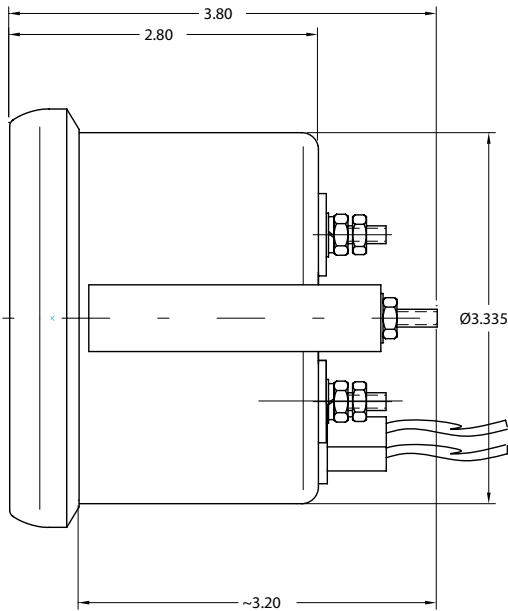

Voltage input

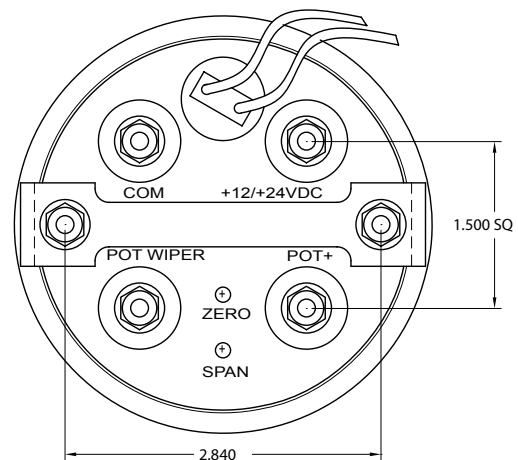

Resistance Bridge input



**LEFT BLANK  
INTENTIONALLY**

**LEFT BLANK  
INTENTIONALLY**

**LEFT BLANK  
INTENTIONALLY**

Yokogawa Corporation of American is a leading world-class manufacturer and provider of meters, transducers, field test instruments, laboratory measuring instruments, recording instruments and industrial controllers in North America.

Yokogawa is committed to a long-term partnership with our customers by meeting future market needs with continuous research and development. Our vision at Yokogawa is to create an environment where plant personnel and operators are well informed, alert, and ready to face the day's next challenge. Quality, innovation, and foresight are what you can expect from all Yokogawa products and their employees.

Yokogawa is the clear choice for operational excellence adapting to many unique challenges in today's world market, maximizing response time by operating four independent business divisions. These divisions are designed to be agile and flexible organizations that provide attention to customer satisfaction while maintaining the technological advances and stability of larger corporations.

Yokogawa Corporation of American is a wholly owned subsidiary of Yokogawa Electric Corporation, a company with more than 90 years experience in the fields of Measuring Instruments and Industrial Controls.

**YOKOGAWA** 

2 Dart Road  
Newnan, Georgia 30265  
770-253-7000 • 800-888-6400 • Fax 770-251-2088  
[www.yokogawa-usa.com](http://www.yokogawa-usa.com)

**Represented by:**

