

THIS DRAWING IS UNPUBLISHED. RELEASED FOR PUBLICATION  
 BY AMP INCORPORATED. ALL RIGHTS RESERVED.

LOC	DIST	REVISIONS					
		P	LTR	DESCRIPTION	DATE	DWN	APVD
BD	35		0	RELEASED -1 PER NPR 5370, WAS 95-7970-18	06/27/95	-	-
			A	ADDED -2 AND REVISED PER EC 0020-900-95	15 SEP 95	DH	AF
			B	REV PER EC 0020-463-96	16 MAY 96	CR	AF

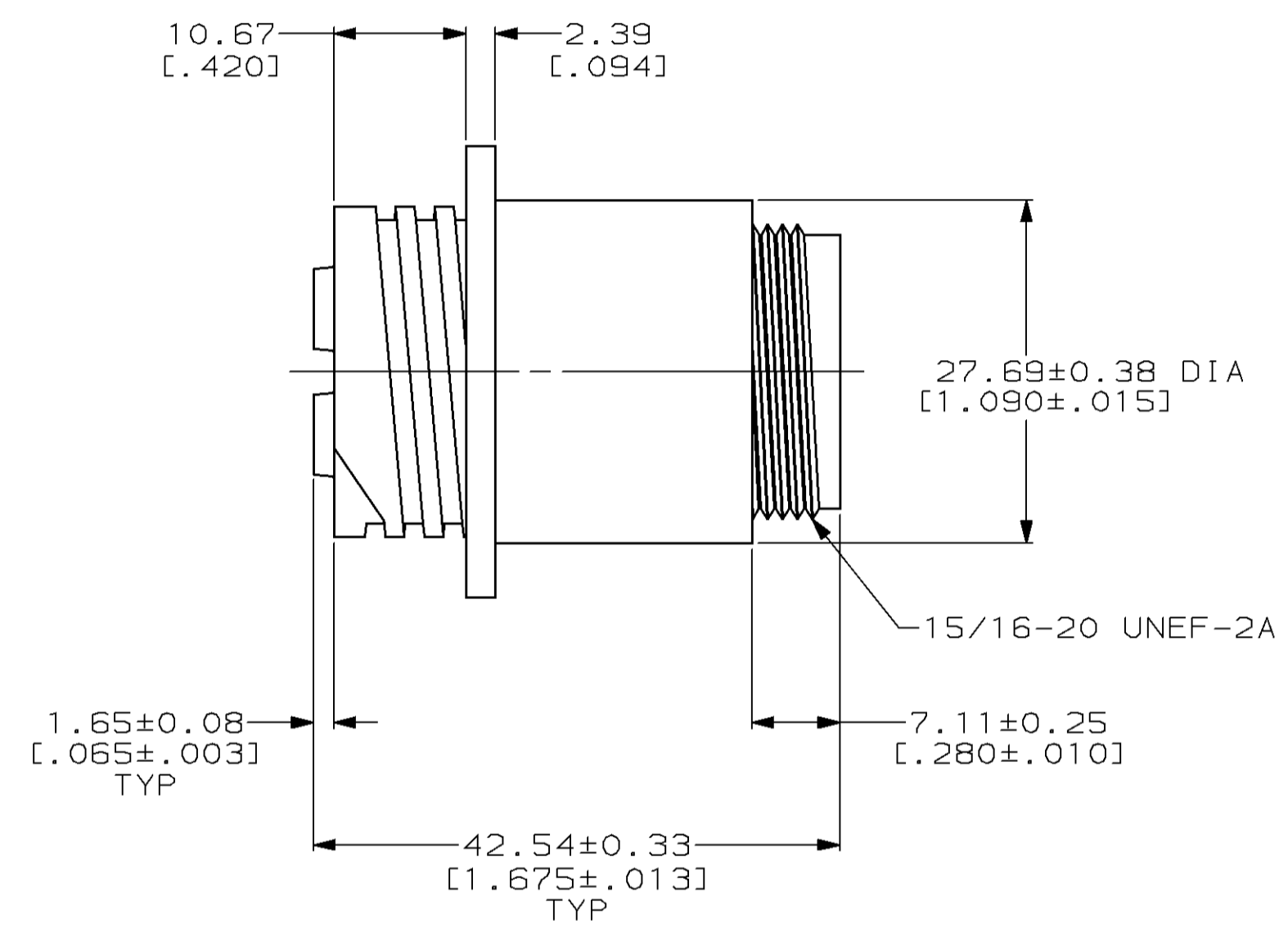
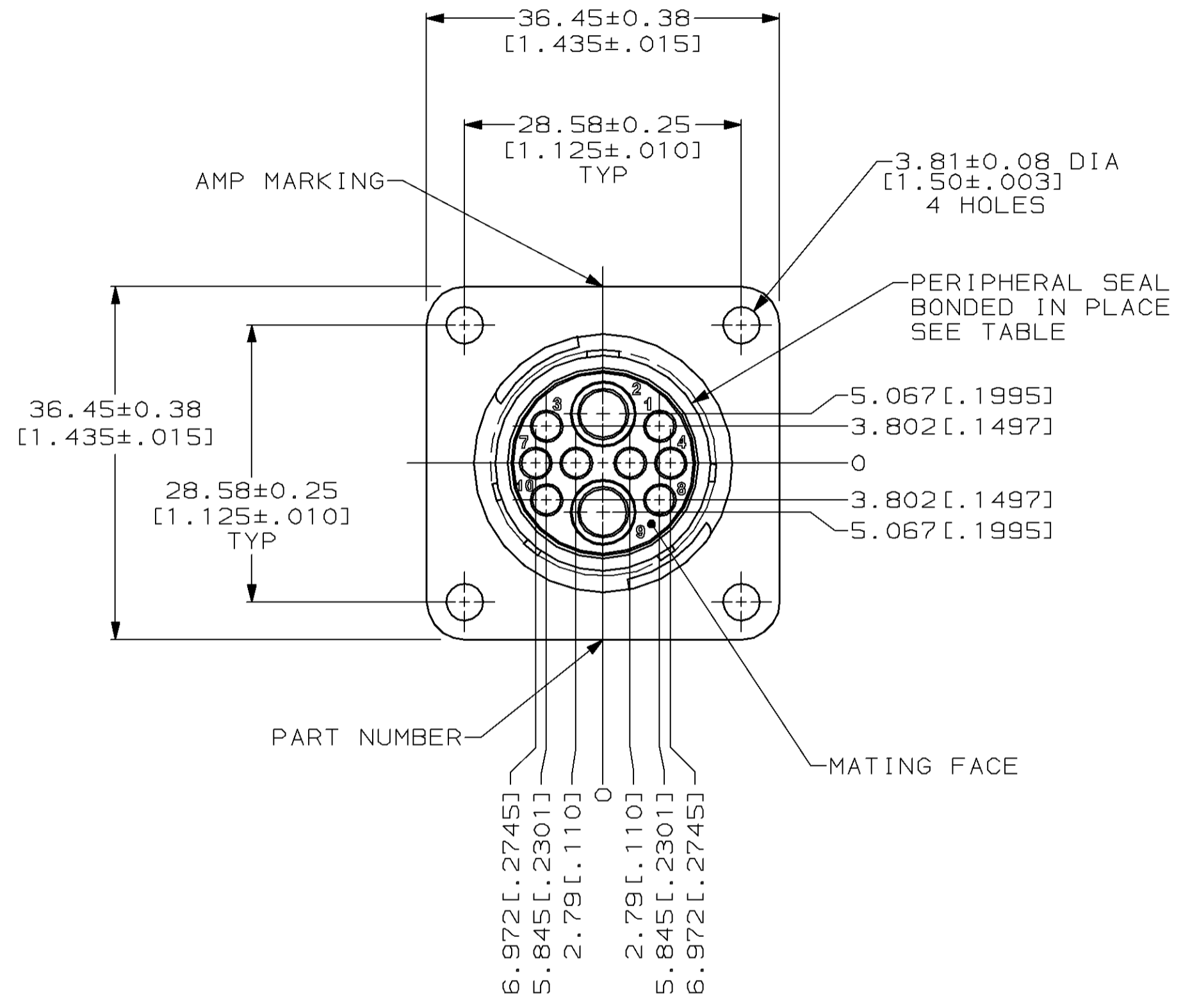

YES	213893-2
NO	213893-1
PERIPHERAL SEAL	PART NUMBER

THIS DRAWING IS A CONTROLLED DOCUMENT FOR AMP INCORPORATED. IT IS SUBJECT TO CHANGE AND THE CONTROLLING ENGINEERING ORGANIZATION SHOULD BE CONTACTED FOR THE LATEST REVISION.		DWN D.HARDY 06/27/95	<b>AMP</b> AMP Incorporated Harrisburg, PA 17105-3608
		CHK R.STONE 06/29/95	
		APVD A.FRANTUM 06/29/95	NAME RECEPTACLE HOUSING, REVERSE SEX, SERIES 6, 17-10, CIRCULAR PLASTIC CONNECTOR
DIMENSIONS: mm [INCHES]		PRODUCT SPEC 108-1579	SIZE A2
TOLERANCES UNLESS OTHERWISE SPECIFIED: 0 PLC ±- 1 PLC ±- 2 PLC ±0.13 [.005] 3 PLC ±0.013 [.0005] 4 PLC ±- ANGLES ±- FINISH -		APPLICATION SPEC -	CAGE CODE 00779
MATERIAL NYLON, BLACK		WEIGHT -	DRAWING NO C-213893
		CUSTOMER DRAWING	SCALE 2:1 SHEET 1 OF 1 REV B

213893