

AC axial fan

sickled blades (S series)

with full square nozzle

ebm-papst Mulfingen GmbH & Co. KG

Bachmühle 2 · D-74673 Mulfingen

Phone +49 7938 81-0

Fax +49 7938 81-110

info1@de.ebmpapst.com

www.ebmpapst.com

Limited partnership · Headquarters Mulfingen
County court Stuttgart · HRA 590344General partner Elektrobau Mulfingen GmbH · Headquarters Mulfingen
County court Stuttgart · HRB 590142

Nominal data

Type	W2D250-GA04-09		
Motor	M2D068-DF		
Phase		3~	3~
Nominal voltage	VAC	400	400
Nominal voltage range	VAC	380 .. 415	380 .. 415
Connection		Y	Y
Frequency	Hz	50	60
Type of data definition		fa	fa
Valid for approval / standard		CE	CE
Speed	min ⁻¹	2750	3050
Power input	W	120	190
Current draw	A	0.27	0.33
Max. back pressure	Pa	115	140
Min. ambient temperature	°C	-25	
Max. ambient temperature	°C	60	75

ml = Max. load · me = Max. efficiency · fa = Running at free air · cs = Customer specs · cu = Customer unit
Subject to alterations

Data according to ErP directive

Installation category	A
Efficiency category	Static
Variable speed drive	No
Specific ratio*	1.00

* Specific ratio = $1 + p_{fs} / 100\,000\text{ Pa}$

	Actual	Request 2013	Request 2015
Overall efficiency η_{es}	25.3	24.5	28.5
Efficiency grade N	36.8	36	40
Power input P_e	kW	0.15	
Air flow q_v	m ³ /h	1255	
Pressure increase p_{fs}	Pa	111	
Speed n	min ⁻¹	2655	

Data definition with optimum efficiency.
The ErP data is determined using a motor-impeller combination in a standardised measurement configuration.



AC axial fan

sickled blades (S series)

with full square nozzle

Technical features

Mass	3 kg
Size	250 mm
Surface of rotor	Coated in black
Material of impeller	Sheet steel, hot-dip galvanised
Material of wall ring	Sheet steel, pre-galvanised and black plastic-coated
Material of guard grille	Steel, phosphated and coated in black plastic
Number of blades	5
Direction of air flow	"V"
Direction of rotation	Counter-clockwise, seen on rotor
Type of protection	IP 00
Insulation class	"B"
Humidity class	F5
Max. permissible ambient motor temp. (transp./ storage)	+ 80 °C
Min. permissible ambient motor temp. (transp./storage)	- 40 °C
Mounting position	Shaft horizontal or rotor on bottom; rotor on top on request
Condensate discharge holes	None
Operation mode	S1
Motor bearing	Ball bearing
Touch current acc. IEC 60990 (measuring network Fig. 4, TN system)	< 0.75 mA
Cable exit	Lateral
Protection class	I (if protective earth is connected by customer)
Product conforming to standard	EN 60335-1
Approval	CCC



AC axial fan

sickled blades (S series)
with full square nozzle

Product drawing

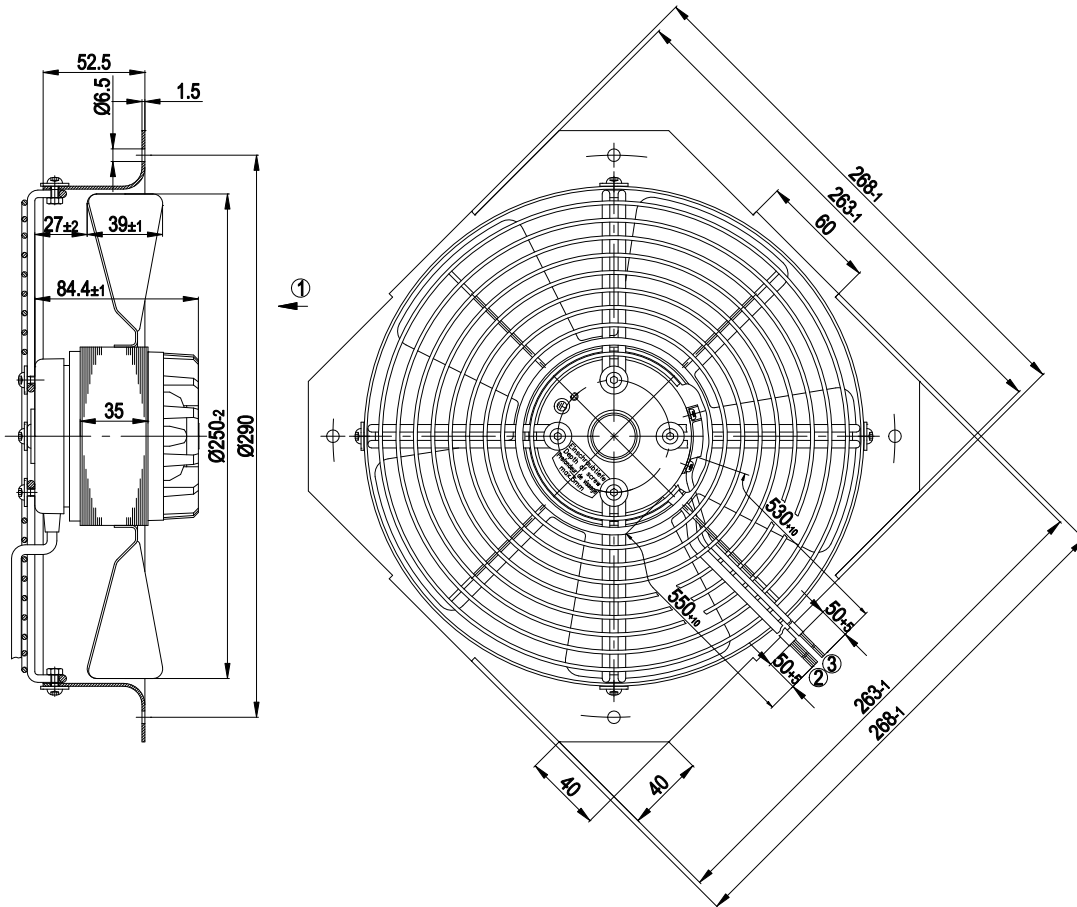

1	Direction of air flow "V"
2	Connection line PVC, 4x brass lead tips crimped
3	Connection for speed monitoring made, AWG24-300V hall generator, motor and hall sensor strands not bared



AC axial fan

sickled blades (S series)
with full square nozzle

Connection screen

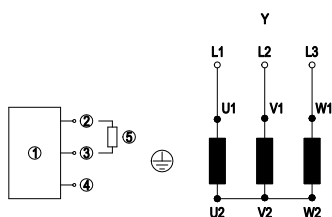

Changing the direction of rotation by reversing the two phases

1	Fan	Y	Star connection	2	Red (+5V)
L1	black	3	White (output)	L2	blue
4	Black (0V)	L3	brown	5	4 K7
TOP	2x grey	PE	green/yellow	Y	Star connection
L1	black	L2	blue	L3	brown

AC axial fan

sickled blades (S series)
with full square nozzle

Charts: Air flow 50 Hz

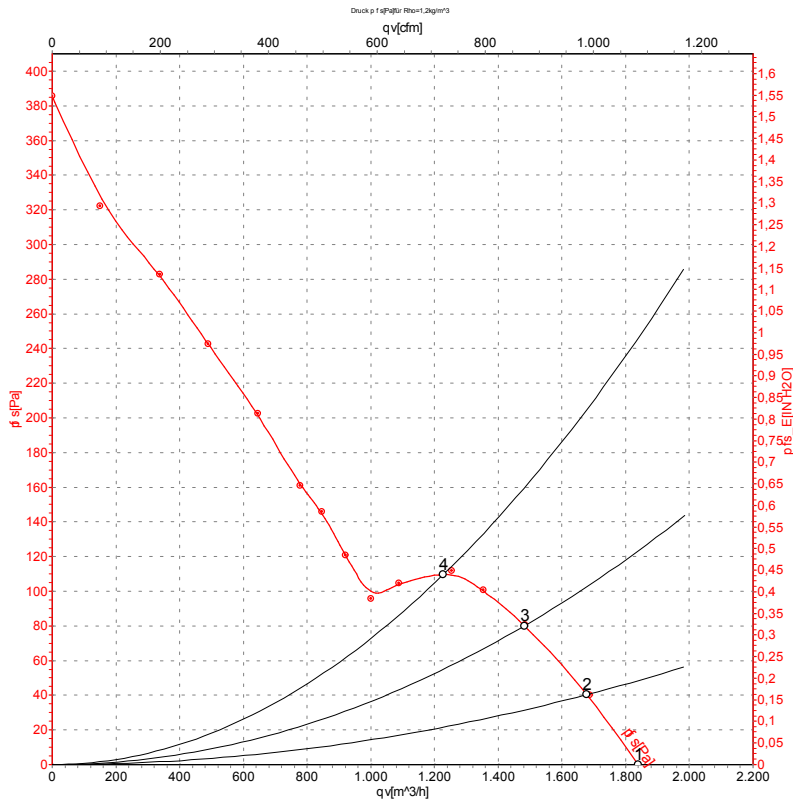

Measurement: LU-14961

Air performance measured as per ISO 5801 Installation category A. For detailed information on the measuring set-up, please contact ebm-papst. Suction-side noise levels: L_{wA} measured as per ISO 13347 / L_{pA} measured with 1m distance to fan axis. The values given are valid under the measuring conditions mentioned above and may vary according to the actual installation situation. With any deviation from the standard set-up, the specific values have to be checked and reviewed with the unit installed.

Measured values

	U	f	n	P _e	I	qv	p _{fs}
	V	Hz	min ⁻¹	W	A	m ³ /h	Pa
1	400	50	2750	120	0.27	1840	0
2	400	50	2695	141	0.29	1680	42
3	400	50	2670	149	0.30	1480	81
4	400	50	2660	151	0.30	1230	111

U = Supply voltage · f = Frequency · n = Speed · P_e = Power input · I = Current draw · qv = Air flow · p_{fs} = Pressure increase



AC axial fan

sickled blades (S series)
with full square nozzle

Charts: Air flow 60 Hz

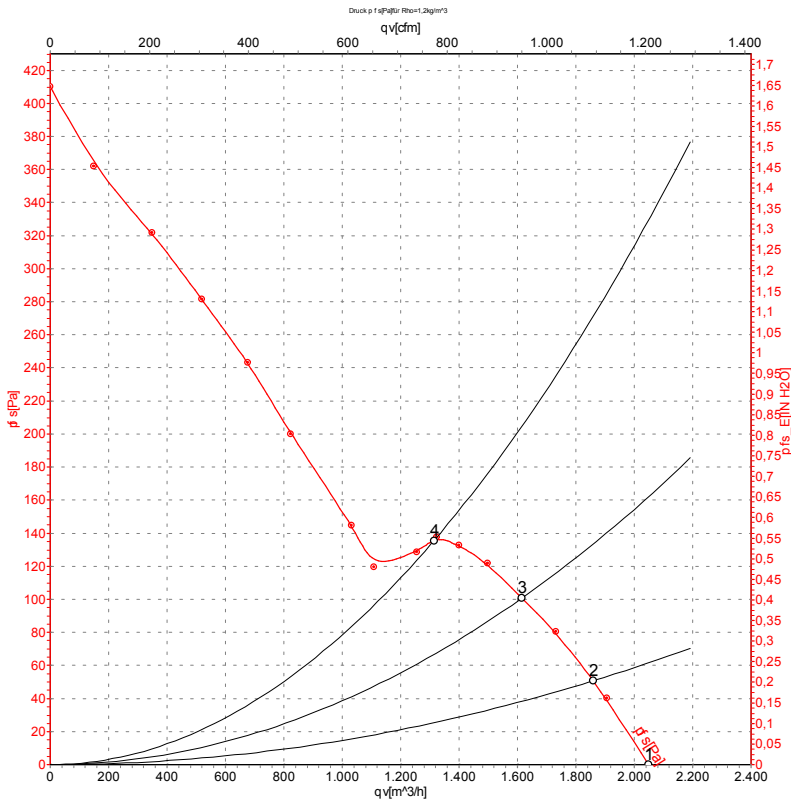

Measurement: LU-14960

Air performance measured as per ISO 5801 Installation category A. For detailed information on the measuring set-up, please contact ebm-papst. Suction-side noise levels: L_{wA} measured as per ISO 13347 / L_{pA} measured with 1m distance to fan axis. The values given are valid under the measuring conditions mentioned above and may vary according to the actual installation situation. With any deviation from the standard set-up, the specific values have to be checked and reviewed with the unit installed.

Measured values

	U	f	n	P _e	I	qv	p _{fs}
	V	Hz	min ⁻¹	W	A	m ³ /h	Pa
1	400	60	3050	190	0.33	2045	0
2	400	60	2985	201	0.34	1860	51
3	400	60	2935	212	0.36	1615	101
4	400	60	2930	209	0.36	1315	136

U = Supply voltage · f = Frequency · n = Speed · P_e = Power input · I = Current draw · qv = Air flow · p_{fs} = Pressure increase

