

SAVE THESE INSTRUCTIONS FOR FUTURE REFERENCE

APPLICATION

The EID disconnect switches are suited for Class I, Division 1 & 2, Groups B, C, D; Class II, Division 1, Groups E, F, G; Class II, Division 2, Groups F, G; Class III; and Class I; Zone 1 & Zone 2, Groups IIB+H2, as defined by the National Electrical Code ® as well as in damp, wet, or corrosive locations.

Additionally, this series is suitable for NEMA 3, 4, 4X applications.

The EID Series disconnect should be installed, inspected, maintained and operated by qualified and competent personnel only.

INSTALLATION

⚠ WARNING

To avoid risk of electrical shock; electrical power must be OFF before and during product installation and maintenance. Failure to comply can result in damage to equipment, injury or death to personnel.

- Select a mounting location that will provide suitable strength and rigidity for supporting the EID product. Weights and dimensions are listed below.

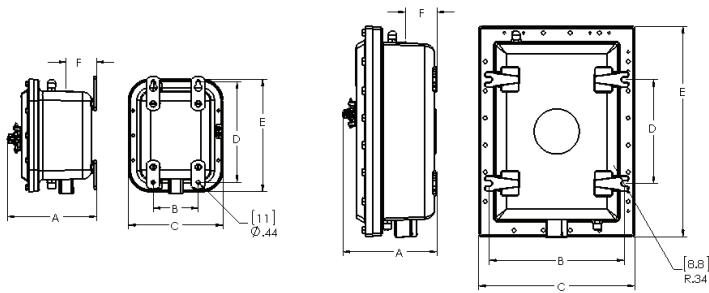

Figure 1

Series	A		B		C		D		E		F		Weight	
	in	mm	in	mm	in	mm	in	mm	in	mm	in	mm	lb	Kg
EIDAE3030/ EIDAE3	9.74	247	5.00	127	10.47	266	11.13	283	12.47	317	3.50	89	33	15
EIDAE3060/ EIDA6	9.90	251	7.00	178	12.53	318	15.13	384	16.53	420	3.50	89	51	23
EIDBE3100/ EIDBE	10.28	261	9.00	229	14.67	373	17.13	435	18.67	474	3.50	89	72	33
EIDAF3030/ EIDAF3	10.02	255	7.00	178	12.67	322	13.13	333	14.67	373	3.50	89	47	21
EIDAF3060/ EIDA6	9.90	251	7.00	178	12.53	318	15.13	384	16.53	420	3.50	89	51	23
EIDBF3100/ EIDBF	10.40	264	15.00	380	17.31	440	11.50	292	23.31	592	3.50	89	108	49

- Securely fasten enclosure to the mounting location, and then attach enclosure into conduit system. Install approved conduit or cable sealing fittings in all conduit entries within 18 inches (46cm) of enclosure per the National Electrical Code ® requirements.

⚠ CAUTION

To avoid risk of explosion; hazardous location information specifying class and group listing of each device is marked on the nameplate of each enclosure. Class and group list for and device penetrating the enclosure must be suitable for the classification of location in which the enclosure is installed. Conduit sealing fittings MUST be installed in each attached conduit run within 18 inches of the enclosure per the National Electrical Code.

- For EID enclosures furnished with disconnect switch, please view Step 4. For EID enclosures furnished without disconnect switch, select appropriate disconnect switch from Table 2 below (ordered separately).

Series	Amperage	Switch Type	Manufacturer	Mfr.'s Part #
EIDAE3030/EIDAE3	30A	Non-fusible	EATON	DS16U
EIDAE3060/EIDA6	60A		EATON	DS26U
EIDBE3100/EIDBE	100A		EATON	DS36U
EIDAF3030/EIDAF3	30A	Fusible	EATON	DS161R
EIDAF3060/EIDA6	60A		EATON	DS262R
EIDBF3100/EIDBF	100A		EATON	DS363R

- Using hardware provided, securely mount disconnect switch on mounting plate with "Line" terminals on top and "Load" terminals on bottom. Use existing holes in mounting plate; please refer to mounting plate drawing below. Be sure to tighten screws to 3 Ft.lbs (0.4 Kg.m).

Mounting Plate Drawing

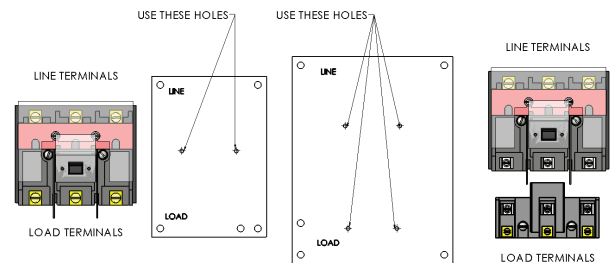

Figure 2

- The rating for each disconnect can be observed in Table 3.

Mfr.'s Part #	Ampere Rating	Fuse Type	Maximum Horse Power Rating			Voltage
			480 VAC	600 VAC	250 VDC	
DS16U	30	N/A	15	20	5	600 VAC, 125/250 VDC
DS26U	60		30	50	10	
DS36U	100		60	75	20	
DS161R	30	Class J H or R	15	20	5	
DS262R	60		30	50	10	
DS363R	100		60	75	20	

- Ensure the operator is in the OFF position and then remove the cover bolts while securing cover. Carefully open the cover fully to prevent damage to the machined joint flame path and cover gasket.

⚠ CAUTION

To avoid the risk of explosion; hammers or prying tools must not be allowed to damage the flat machined-joint surfaces or cover gasket. Do not handle covers roughly or place them on surfaces that might damage or scratch the flat-machined joint surfaces.

⚠ CAUTION

To avoid the risk of explosion; do not use cover bolts as a means to lift the enclosure. Excessive force on the partially retracted cover bolts may damage the bolt. Use appropriate lifting method for safety.

- Pull wires into enclosure, making sure they are long enough to make the required electrical connections. Install the proper wire clamps or other approved devices to hold the wires securely in place. Install the ground, line, and load wires. Tighten the wire binding screws to torque values shown on Table 4.

Note:

a. The internal grounding terminal shall be used as equipment grounding means. The external terminal is only a supplemental bonding connection.

Table 4		Terminal Torque Value		
Series	Amperage	Wire Range	in-lb.	N-m
EIDAE3030/EIDAE3	30A	#10-#8 AWG	35-40	4-5
EIDAE3060/EIDA6	60A	#6-#3 AWG	45	5
EIDBE3100/EIDBE	100A	#1-1/0 AWG	50	6
EIDAF3030/EIDAF3	30A	#10-#8 AWG	35-40	4-5
EIDAF3060/EIDA6	60A	#6-#3 AWG	45	5
EIDBF3100/EIDBF	100A	#1-1/0 AWG	50	6

b. Maximum wire sizes are recommended based on NEC minimum wire bending space at each terminal per designated enclosure. Select wire gauge per NEC standard.

c. Table 4 list maximum wire gauges for 55°C Ambient Temperature.

d. Use copper wire only. Wire to be rated at 75/90°C.

- For fusible disconnects, install Class J, H or R fuses. Contact Eaton's Bussmann Business for more fuse information.
- Test wiring for good connection by performing a continuity check. Also, check for unwanted grounds with an insulation resistance tester.

CAUTION

To avoid the risk of explosion; Clean both machined-joint surfaces of body and cover before closing. Dirt or foreign material must not accumulate on flat machined-joint surfaces. Surfaces must seat fully against each other to provide a proper explosion-proof joint.

- Make sure that operator and fork are in the OFF position.

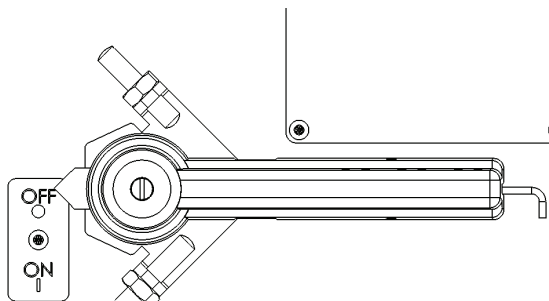

Figure 3

- Fully tighten all cover bolts. See Table 5.

Table 5		Torque Value	
Series	Cover Screw	ft-lb	N-m
EIDAE3030/EIDAE3	5/16"-18	20-25	27-34
EIDAE3060/EIDA6	3/8"-16	35-40	48-54
EIDBE3100/EIDBE	3/8"-16	35-40	48-54
EIDAF3030/EIDAF3	3/8"-16	35-40	48-54
EIDAF3060/EIDA6	3/8"-16	35-40	48-54
EIDBF3100/EIDBF	1/2"-13	40-45	54-61

CAUTION

To avoid the risk of explosion; all unused conduit openings must be closed properly with an approved plug, drain or breather such as the Crouse-Hinds PLG series plugs or ECD Series Breather/Drains. NO CONDUIT OPENINGS ARE TO BE ADDED IN THE FIELD.

MAINTENANCE:

WARNING

To avoid electrical shock and personal injury; always disconnect primary power source before opening enclosure for inspection or service, and lock them out.

- Electrical and mechanical inspections must be done on a regular basis. It is recommended that inspections be performed a minimum of once a year.
- If necessary to open enclosure for inspection or service, always disconnect primary power source and refer to cautionary statement or nameplate before opening cover. Area must be free of flammable gases and vapor before opening cover.
- Perform visual check for undue heating evidenced by discoloration of wires or other components, damage or worn parts, or leakage evidenced by water or corrosion in the interior.
- Electrically check to make sure that all connections are clean and tight and that contacts in the components make and break as required.
- Mechanically check that all parts are properly assembled and operating mechanisms move freely.
 - For more operator adjustment instructions see figure 4 on page 3.

FORK ADJUSTMENT:

1. ASSEMBLE OPERATOR INTO COVER.
2. MEASURE DISTANCE FROM BODY FLANGE TO BOTTOM OF TOGGLE (DIMENSION A).
3. MEASURE DISTANCE FROM INSIDE OF COVER TO BOTTOM OF FORK (DIMENSION B).
4. ADJUST FORK UP OR DOWN SO THAT $[B = A - 0.12"]$.
5. MOVE BREAKER TOGGLE TO "OFF" POSITION AND OPERATOR HANDLE TO "OFF" POSITION.
6. CLOSE COVER AND CHECK BREAKER OPERATION.
7. ADJUST FORK UP OR DOWN TO OPTIMIZE BREAKER OPERATION.

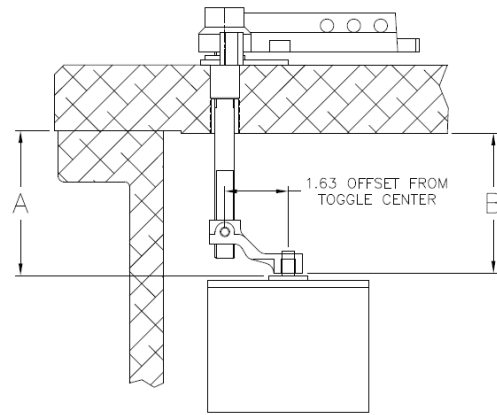

STOP ADJUSTMENT:

1. MOVE OPERATOR TO "ON" POSITION.
2. PUT LIGHT PRESSURE ON HANDLE IN THE "ON" DIRECTION AND HOLD IN THAT POSITION. FORK SHOULD BE TOUCHING TOGGLE.
3. TURN STOP SCREW UNTIL IT TOUCHES HANDLE.
4. TIGHTEN STOP NUT.
5. MOVE OPERATOR TO "OFF" POSITION.
6. PUT NORMAL PRESSURE ON HANDLE IN THE "OFF" DIRECTION UNTIL THE HANDLE STOPS. HOLD IN THAT POSITION. THIS REPRESENTS THE RESET POSITION.
7. TURN STOP SCREW UNTIL IT TOUCHES HANDLE.
8. TIGHTEN STOP NUT.

Figure 4

Eaton's Crouse-Hinds Business recommends an Electrical Preventative Maintenance Program as described in the National Fire Protection Association Bulletin NFPA 70B.

All statements, technical information and recommendations contained herein are based on information and tests we believe to be reliable. The accuracy or completeness thereof are not guaranteed. In accordance with Crouse-Hinds "Terms and Conditions of Sale," and since conditions of use are outside our control, the purchaser should determine the suitability of the product for his intended use and assumes all risk and liability whatsoever in connection therewith.